

ELECTRO-MAGNETIC INDUCTION BRAKE MOTOR, TERMINAL BOX TYPE -IP54

感應式電磁剎車馬達 接線盒式-防護等級IP54

- 外形圖與規格表
- OUTLINE & SPECIFICATION
- 單位/UNIT : mm

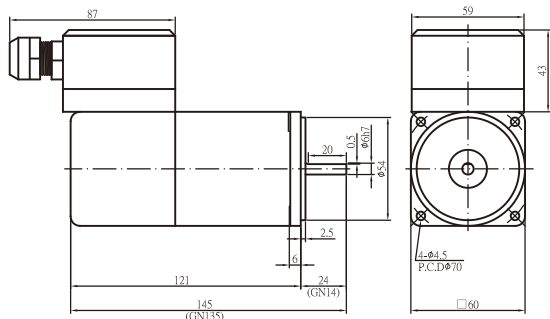

6W外型圖

6W機型MODEL	出力(W) OUTPUT	電壓(V) VOLTAGE	頻率(HZ) FREQ.	極數(P) POLE	額定轉數(rpm) RATED SPEED	額定時間 RATED TIME	起動轉矩(Kg.cm) STARTING TORQUE	額定轉矩(Kg.cm) RATED TORQUE	額定電流(A) RATED CURRENT	電容量(μF) CAPACITY
2IK6A(GN)-AMT	6	1ø100/110	50/60	4	1150/1400	30分鐘/minutes	0.7/0.63	0.51/0.41	0.22/0.21	2.5/300V
2IK6A(GN)-CMT	6	1ø200/220	50/60	4	1150/1550	30分鐘/minutes	0.65/0.7	0.51/0.54	0.1/0.11	0.7/450V
2IK6A(GN)-CEMT	6	1ø230/240	50	4	1100/1200	30分鐘/minutes	0.74/0.77	0.55/0.5	0.11/0.1	0.7/450V

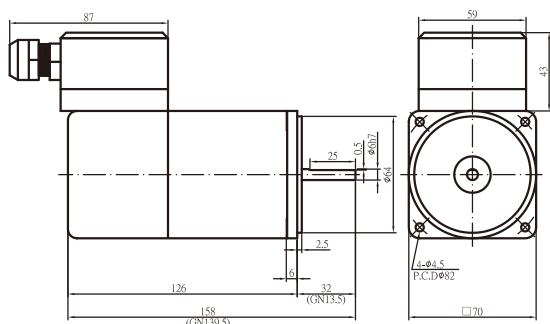

15W外型圖

15W機型MODEL	出力(W) OUTPUT	電壓(V) VOLTAGE	頻率(HZ) FREQ.	極數(P) POLE	額定轉數(rpm) RATED SPEED	額定時間 RATED TIME	起動轉矩(Kg.cm) STARTING TORQUE	額定轉矩(Kg.cm) RATED TORQUE	額定電流(A) RATED CURRENT	電容量(μF) CAPACITY
3IK15A(GN)-AMT	15	1ø100/110	50/60	4	1150/1650	30分鐘/minutes	0.88/1.04	1.22/0.91	0.36/0.35	5/300V
3IK15A(GN)-CMT	15	1ø200/220	50/60	4	1150/1600	30分鐘/minutes	0.75/1.1	1.12/0.93	0.18/0.18	1.2/450V
3IK15A(GN)-CEMT	15	1ø230/240	50	4	1300/1300	30分鐘/minutes	1.06/1.06	1.14/1.13	0.17/0.17	1.2/450V

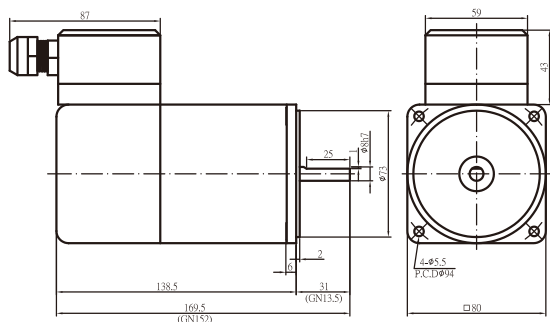

25W外型圖

25W機型MODEL	出力(W) OUTPUT	電壓(V) VOLTAGE	頻率(HZ) FREQ.	極數(P) POLE	額定轉數(rpm) RATED SPEED	額定時間 RATED TIME	起動轉矩(Kg.cm) STARTING TORQUE	額定轉矩(Kg.cm) RATED TORQUE	額定電流(A) RATED CURRENT	電容量(μF) CAPACITY
4IK25A(GN)-AMT	25	1ø100/110	50/60	4	1250/1600	30分鐘/minutes	1.4/1.4	1.93/1.51	0.57/0.45	6/300V
4IK25A(GN)-CMT	25	1ø200/220	50/60	4	1250/1600	30分鐘/minutes	1.57/1.38	1.91/1.52	0.28/0.25	1.5/450V
4IK25A(GN)-CEMT	25	1ø230/240	50	4	1300/1300	30分鐘/minutes	1.38/1.55	1.9/1.86	0.25/0.24	1.5/450V
4IK25A(GN)-SMT	25	3ø220	50/60	4	1300/1550	30分鐘/minutes	5.12/4.04	1.89/1.56	0.22/0.19	-
4IK25A(GN)-UMT	25	3ø380	50/60	4	1200/1350	30分鐘/minutes	3.96/2.97	2.04/1.79	0.11/0.11	-

備註 NOTES :

- 感應式電磁剎車馬達之使用頻率不可大於10次/分。The applicable frequency for the ELECTRO-MAGNETIC INDUCTION BRAKE MOTOR should not exceed more than 10 times per minute.
- 感應式電磁剎車馬達之靜摩擦轉矩：6W~25W: 4Kg.cm, 40W~90W: 10Kg.cm. Static friction torque of a ELECTRO-MAGNETIC INDUCTION BRAKE MOTOR is: 6W~25W: 4Kg.cm, 40W~90W: 10Kg.cm.

泛用型馬達
GENERAL PURPOSE MOTOR

速度控制型馬達
SPEED CONTROLLED MOTOR

控制器
CONTROLLER

煞車馬達
BRAKE MOTOR

離合煞車馬達
CLUTCH BRAKE MOTOR

轉矩馬達
TORQUE MOTOR

減速機
SPEED REDUCER

零組件類
COMPONENTS

ELECTRO-MAGNETIC INDUCTION BRAKE MOTOR, TERMINAL BOX TYPE -IP54

感應式電磁剎車馬達 接線盒式-防護等級IP54

- 外形圖與規格表
- OUTLINE & SPECIFICATION
- 單位/UNIT : mm

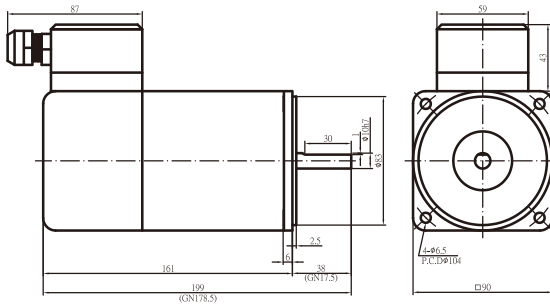

40W外型圖

40W機型MODEL	出力(W) OUTPUT	電壓(V) VOLTAGE	頻率(HZ) FREQ	極數(P) POLE	額定轉數(rpm) RATED SPEED	額定時間 RRATED TIME	起動轉矩(Kg.cm) STARTING TORQUE	額定轉矩(Kg.cm) RATED TORQUE	額定電流(A) RATED CURRENT	電容量(μF) CAPACITY
5IK40A(GN)-AMT	40	1φ100/110	50/60	4	1250/1600	30分鐘/minutes	2.14/2.66	3.17/2.41	0.87/0.76	10/300V
5IK40A(GN)-CMT	40	1φ200/220	50/60	4	1300/1650	30分鐘/minutes	1.75/2.17	3.01/2.35	0.4/0.34	2.5/450V
5IK40A(GN)-CEMT	40	1φ230/240	50	4	1350/1350	30分鐘/minutes	2.3/2.58	2.87/2.84	0.32/0.32	2.5/450V
5IK40A(GN)-SMT	40	3φ220	50/60	4	1400/1600	30分鐘/minutes	10.51/7.83	2.83/2.4	0.29/0.27	-
5IK40A(GN)-UMT	40	3φ380	50/60	4	1350/1600	30分鐘/minutes	9.25/6.68	2.85/2.45	0.16/0.15	-

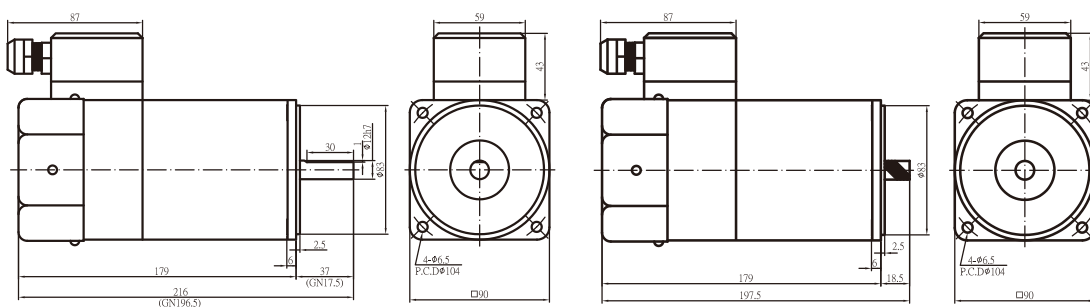

60W/60W-GX外型圖

60W/60W-GX機型MODEL	出力(W) OUTPUT	電壓(V) VOLTAGE	頻率(HZ) FREQ.	極數(P) POLE	額定轉數(rpm) RATED SPEED	額定時間 RATED TIME	起動轉矩(Kg.cm) STARTING TORQUE	額定轉矩(Kg.cm) RATED TORQUE	額定電流(A) RATED CURRENT	電容量(μF) CAPACITY
5IK60A(GN)-AFMT 5IK60GX-AFMT	60	1φ100/110	50/60	4	1200/1650	30分鐘/minutes	2.6/2.94	5.0/3.5	1.8/1.12	16/300V
5IK60A(GN)-CFMT 5IK60GX-CFMT	60	1φ200/220	50/60	4	1250/1600	30分鐘/minutes	3.62/4.41	4.64/3.63	0.64/0.54	4/450V
5IK60A(GN)-CEFMT 5IK60GX-CEFMT	60	1φ220/240	50	4	1300/1350	30分鐘/minutes	4.14/5.22	4.56/4.40	0.56/0.55	4/450V
5IK60A(GN)-SFMT 5IK60GX-SFMT	60	3φ220	50/60	4	1300/1550	30分鐘/minutes	13.72/10.70	4.47/3.77	0.41/0.39	-
5IK60A(GN)-UFMT 5IK60GX-UFMT	60	3φ380	50/60	4	1400/1550	30分鐘/minutes	14.33/10.15	4.2/3.79	0.21/0.22	-

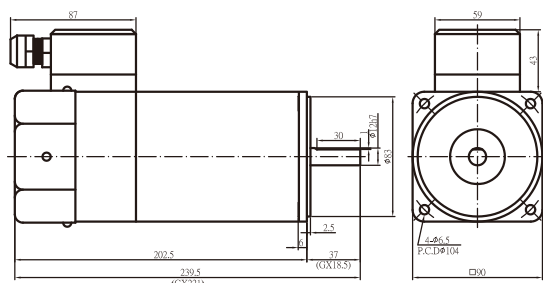

90W外型圖

90W機型MODEL	出力(W) OUTPUT	電壓(V) VOLTAGE	頻率(HZ) FREQ.	極數(P) POLE	額定轉數(rpm) RATED SPEED	額定時間 RATED TIME	起動轉矩(Kg.cm) STARTING TORQUE	額定轉矩(Kg.cm) RATED TORQUE	額定電流(A) RATED CURRENT	電容量(μF) CAPACITY
5IK90A(GX)-AFMT	90	1φ100/110	50/60	4	1300/1650	30分鐘/minutes	4.76/5.86	6.68/5.33	1.5/1.41	22/250V
5IK90A(GX)-CFMT	90	1φ200/220	50/60	4	1300/1650	30分鐘/minutes	4.3/4.21	6.89/5.34	0.76/0.72	5/450V
5IK90A(GX)-CEFMT	90	1φ220/240	50	4	1350/1350	30分鐘/minutes	4.93/5.08	6.44/6.42	0.66/0.68	5/450V
5IK90A(GX)-SFMT	90	3φ220	50/60	4	1400/1650	30分鐘/minutes	23.3/18.25	6.4/5.3	0.7/0.6	-
5IK90A(GX)-UFMT	90	3φ380	50/60	4	1400/1650	30分鐘/minutes	23.3/18.14	6.3/5.3	0.4/0.3	-

Products due to human error, natural disasters or other factors lead to poor or damaged, will not be covered under warranty. 產品因人為原因或天災等因素導致不良或損壞, 不在保固範圍內。