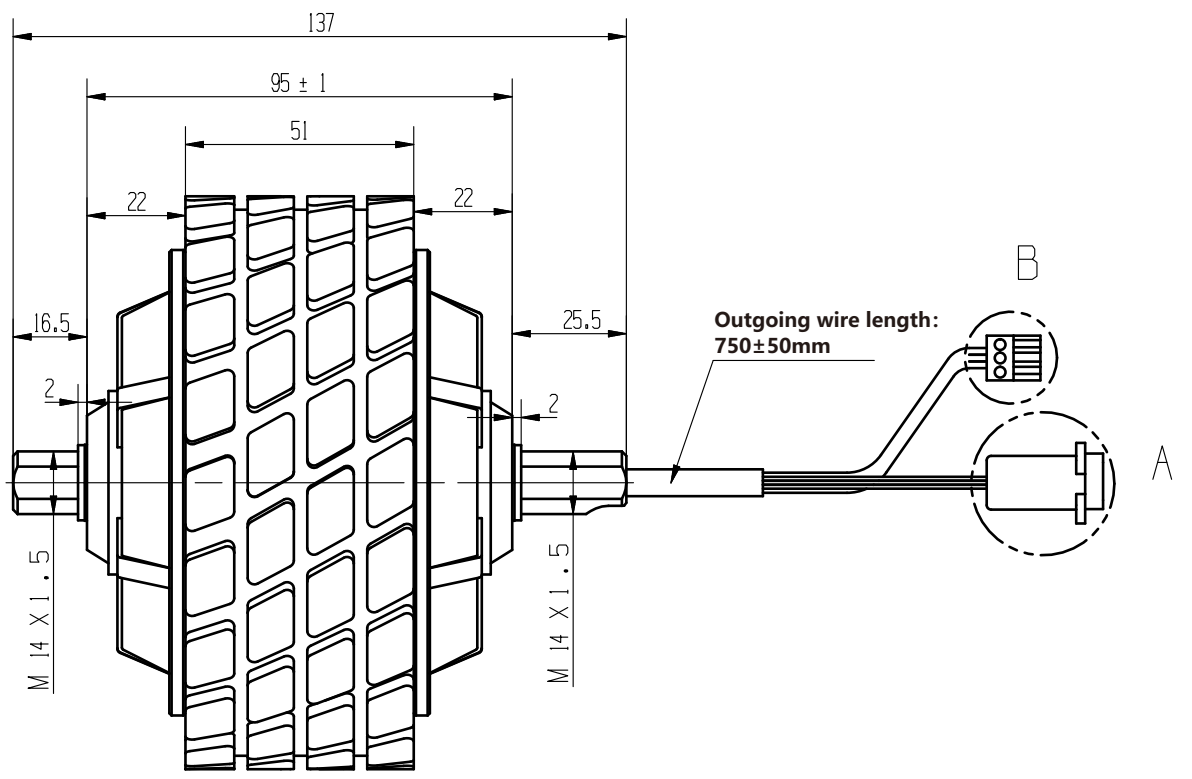
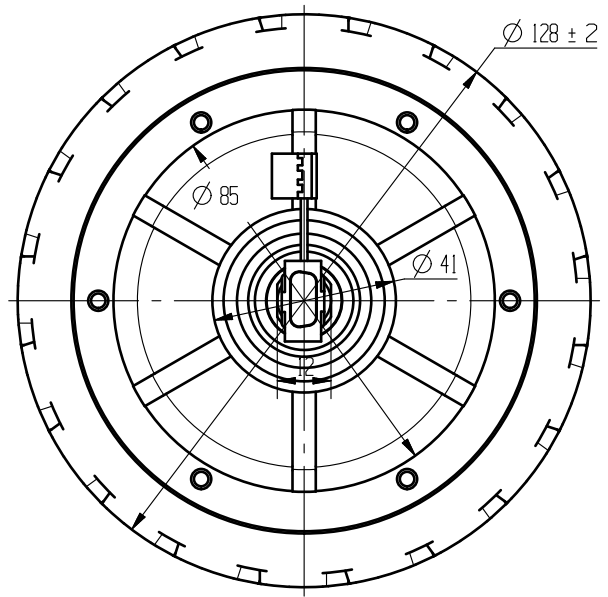



photo-realistic

photo-realistic

photo-realistic



Rated Voltage	Power	Rated Torque	Maximum Torque	Rated Speed	Maximum Speed	Rated Phase Current	Max Phase Current
24VDC	200W	6N.m	12N.m	300RPM	400RPM	5-15A	30A
Wheel Diameter	Weight	Shaft Type	Encoder	Tire	Brake Type	Protection Level	Suggested Load
128mm	3KG	Double Shaft	1024-wire optical encoder	PU Pattern	Electric brake	IP65	150KG

Power Wire				Signal Wire				Temperature Sensor					
Pin	1	2	3	Pin	5	4	3	2	1	8	7	NC	NC
Color	Blue	Yellow	Green	Color	Blue	Yellow	Green	Red	Black	Brown	White	Purple	Grey
Signal	Power Wire W	Power Wire U	Power Wire V	Signal	Hall V	Hall U	Hall W	+5V	GND	Encoder A+	Encoder B+	Thermistor +	Thermistor -

	Design change	1		View		Design:	Date:	Company Name: YTK Co., Ltd
		2				Proofread:	Date:	Product Name: Hub Servo Motor
		3				Approve:	Date:	Product P/N: ZLLG45ASM200(Double Shaft Pattern Oil Seal)
		4		ERP:				