

Application : Rearview Mirror 、 Electric Shaver 、 Door Locks

用途 : 後視鏡鏡面調整、電動刮鬍刀、門鎖

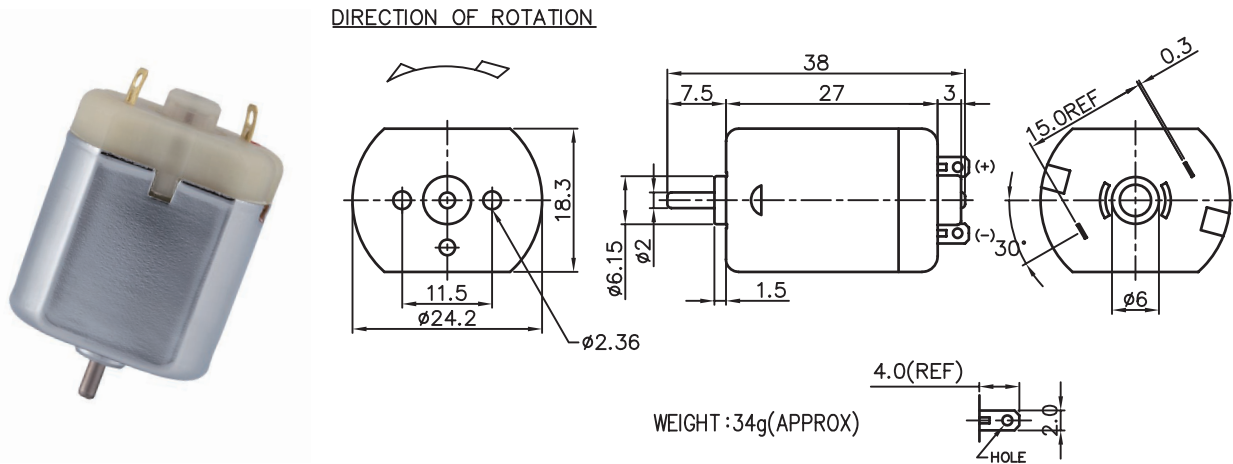

MODEL	VOLTAGE		NO LOAD		AT MAXIMUM EFFICIENCY						STALL		
	OPERATING RANGE	NOMNAL	SPEED	CURRENT	SPEED	CURRENT	TORQUE	OUTPUT	EFF	CURRENT	TORQUE		
			rpm	A	rpm	A	g-cm	mN-m	W	%	A	g-cm	mN-m
PC-260-18160-NR	3.0 - 9.0	6.0V CONSTANT	10000	0.14	7600	0.49	18	1.76	1.45	49	1.98	96	9.41
PC-260S-16220-NR	6.0 -18.0	12.0V CONSTANT	11600	0.13	9000	0.45	32	3.18	3.00	57	1.85	155	15.19
PC-260S-08600-NR	6.0 -24.0	12.0V CONSTANT	4000	0.03	2800	0.08	12	1.18	0.36	40	0.21	48	4.71
PC-260S-09480-NR	6.0 -24.0	12.0V CONSTANT	5000	0.04	3500	0.11	15	1.47	0.55	43	0.30	55	5.39

馬達的出軸長度及性能參數，EMC 對策可依客人要求做調整，詳情可詢問相關業務人員。
Please inquire your sales representative for output, performance and EMC solution.

