

Application : Massager、R/C Car、Portable Fan

用途：電動按摩器、遙控車、小風扇

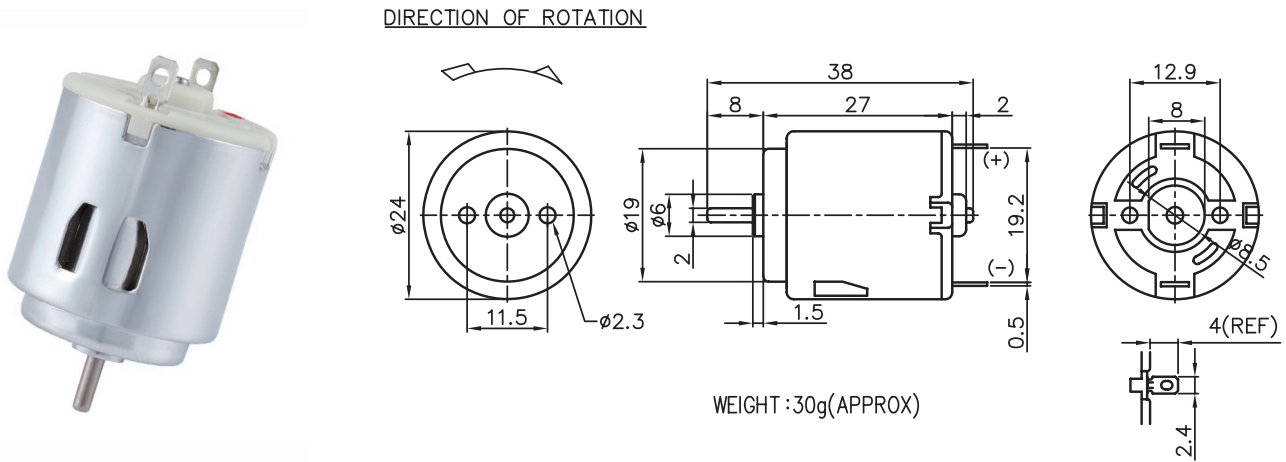

MODEL	VOLTAGE		NO LOAD		AT MAXIMUM EFFICIENCY						STALL		
	OPERATING RANGE	NOMNAL	SPEED	CURRENT	SPEED	CURRENT	TORQUE	OUTPUT	EFF	CURRENT	TORQUE		
			rpm	A	rpm	A	g-cm	mN-m	W	%	A	g-cm	mN-m
FC-260-2670-NR	3.0 - 4.5	3.0V CONSTANT	10000	0.30	7800	1.09	16.83	1.65	1.35	41.40	3.97	78	7.65
FC-260-09420-NR	6.0 - 18.0	12.0V CONSTANT	7850	0.08	5685	0.16	12.23	1.20	0.71	38.85	0.45	51	5.00
FC-260-15190-NR	6.0 - 12.0	6.0V CONSTANT	8600	0.14	6173	0.34	16.32	1.60	1.03	50.97	1.26	76	7.45
FC-260-07520-NR	12.0 - 24.0	24.0V CONSTANT	12400	0.07	9500	0.14	15.88	1.56	1.56	47.85	0.47	70	6.86

馬達的出軸長度及性能參數，EMC 對策可依客人要求做調整，詳情可詢問相關業務人員。
Please inquire your sales representative for output, performance and EMC solution.

