

RK-290

Carbon-brush motors

Application : Electric Window/Curtain

用途：電動開窗器、智能窗簾

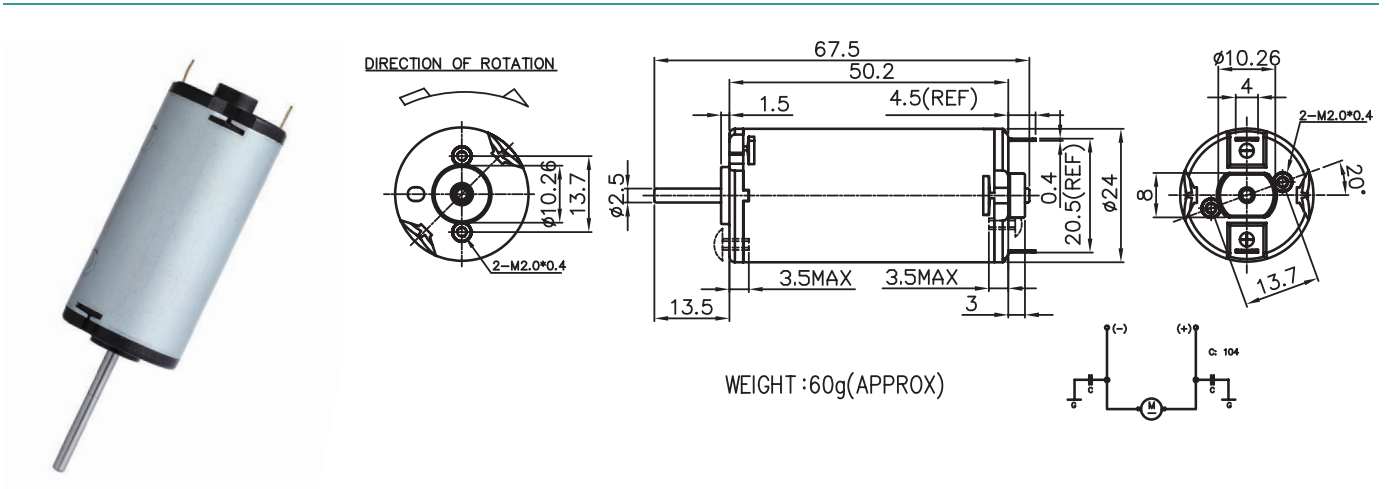

MODEL	VOLTAGE		NO LOAD		AT MAXIMUM EFFICIENCY					STALL			
	OPERATING RANGE	NOMNAL	SPEED	CURRENT	SPEED	CURRENT	TORQUE	OUTPUT	EFF	CURRENT	TORQUE		
			rpm	A	rpm	A	g-cm	mN-m	W	%	A	g-cm	mN-m
RK-290B-17230S-R-CE	18.5-29.5	24.0V CONSTANT	7800	0.12	5760	0.53	124.8	12.24	7.38	60	1.85	526	51.56
RK-290B-20150-R-CE	12.0-24.0	12.0V CONSTANT	6200	0.16	4792	0.54	83.1	8.15	4.09	66	2.43	454	44.51
RK-290B-14295-R-CE	12.0-36.0	24.0V CONSTANT	6000	0.09	4861	0.27	81.6	8.00	4.07	66	1.24	457	44.80
RK-290XB-3263-R-CE	6.0-12.0	7.0V CONSTANT	6600	0.40	5624	1.52	128.5	12.60	7.42	72	8.77	927	90.88

馬達的出軸長度及性能參數，EMC 對策可依客人要求做調整，詳情可詢問相關業務人員。
Please inquire your sales representative for output, performance and EMC solution.

