

Application : Hair Clipper 、 Massager 、 R/C Car 、 Central Locks

用途：電動理髮器、電動按摩器、遙控車、中控鎖

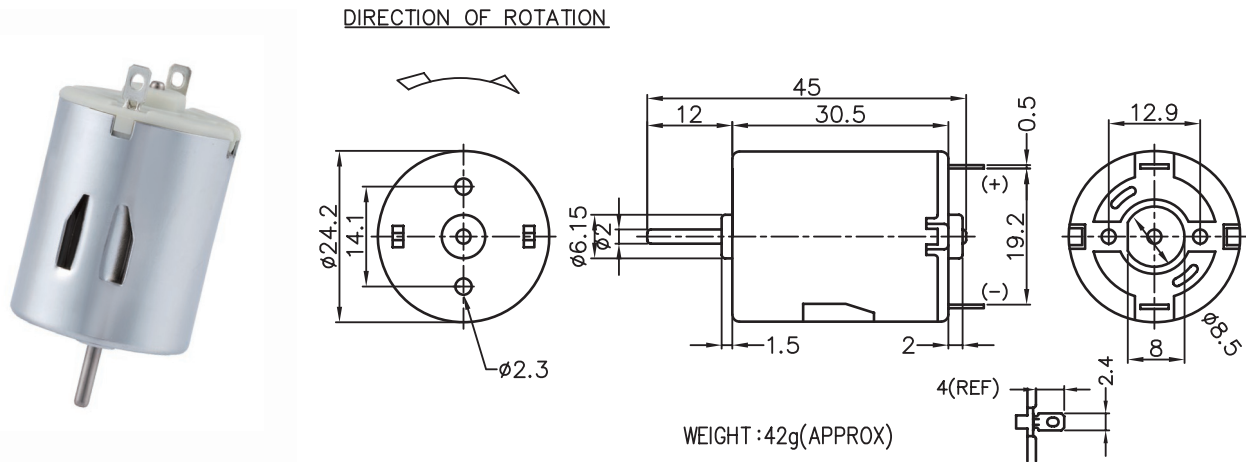

MODEL	VOLTAGE		NO LOAD		AT MAXIMUM EFFICIENCY					STALL			
	OPERATING RANGE	NOMNAL	SPEED	CURRENT	SPEED	CURRENT	TORQUE	OUTPUT	EFF	CURRENT	TORQUE		
			rpm	A	rpm	A	g-cm	mN-m	W	%	A	g-cm	mN-m
FC-280-20120-NR	4.5 - 9.0	6.0V CONSTANT	10000	0.13	7800	0.60	21.62	2.11	1.70	50.00	2.23	105	10.29
FC-280S-09400-NR	12.0-24.0	12.0V CONSTANT	4500	0.05	3095	0.14	21.57	2.11	0.69	43.00	0.41	85	8.33
FC-280SB-22105-NR	4.5 - 9.0	4.5V CONSTANT	6400	0.16	5147	0.59	26.23	2.57	1.39	54.00	2.76	157	15.39
FC-280S-20120-NR	4.5 - 12.0	12.0V CONSTANT	14500	0.16	12200	0.88	49.17	4.82	6.19	58.63	5.40	320	31.37

馬達的出軸長度及性能參數，EMC 對策可依客人要求做調整，詳情可詢問相關業務人員。
Please inquire your sales representative for output, performance and EMC solution.

