

Application : Warning Light、Pump、ATM

用途：警示燈、泵浦、自動提款機

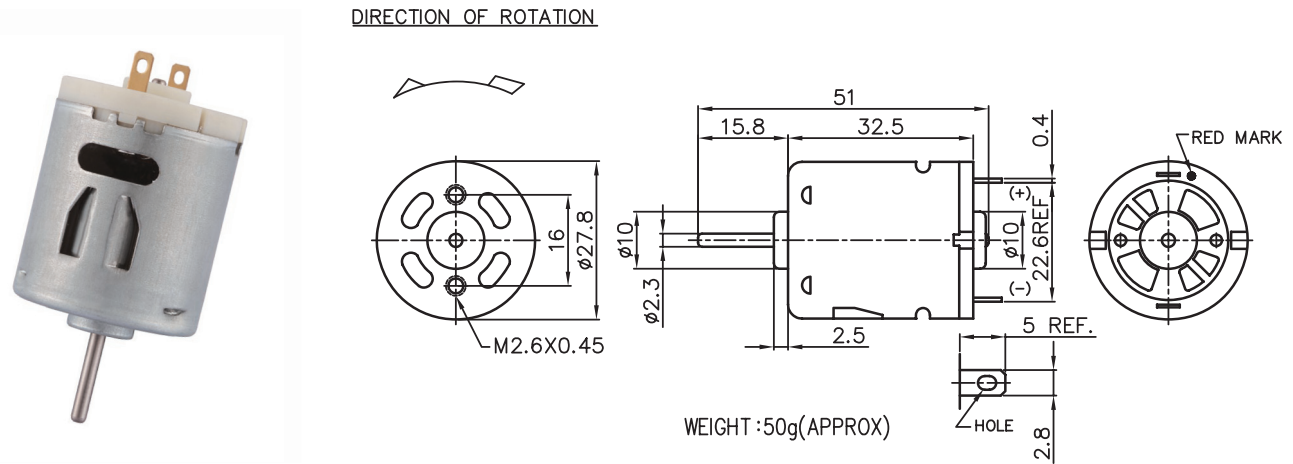

MODEL	VOLTAGE		NO LOAD		AT MAXIMUM EFFICIENCY						STALL		
	OPERATING RANGE	NOMNAL	SPEED	CURRENT	SPEED	CURRENT	TORQUE	OUTPUT	EFF	CURRENT	TORQUE		
			rpm	A	rpm	A	g-cm	mN-m	W	%	A	g-cm	mN-m
MP3N-3263-R	3.0 - 6.0	4.2V CONSTANT	9500	0.48	8065	1.74	57	5.59	4.75	66	9.88	403	39.51
MD3N-18195-R	6.0 - 12.0	7.2V CONSTANT	5500	0.17	4153	0.49	48	4.71	2.04	60	1.90	229	22.45
MD3N-22140-R	4.5 - 12.0	12.0V CONSTANT	13500	0.40	11325	1.19	88	8.63	10.19	75	5.53	511	50.10
MD3N-12340-R	12.0 - 24.0	12.0V CONSTANT	4800	0.11	3903	0.24	40	3.92	1.59	55	0.87	184	18.04

馬達的出軸長度及性能參數，EMC 對策可依客人要求做調整，詳情可詢問相關業務人員。  
Please inquire your sales representative for output, performance and EMC solution.

