

Application : Hair Dryer、Printer、Vacuum Robot

用途：吹風機、印表機、智能吸塵機器人

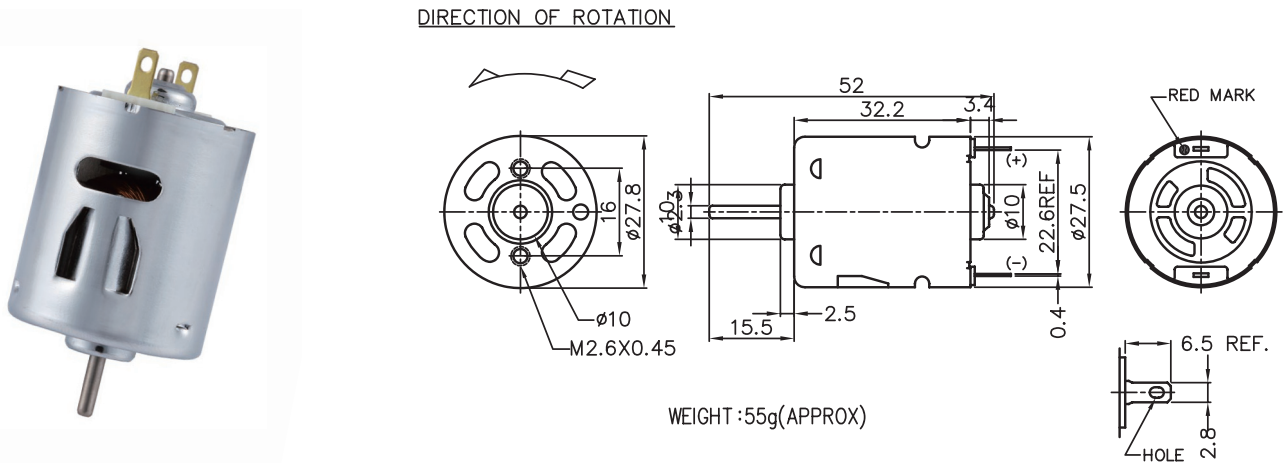

MODEL	VOLTAGE		NO LOAD		AT MAXIMUM EFFICIENCY						STALL		
	OPERATING RANGE	NOMNAL	SPEED	CURRENT	SPEED	CURRENT	TORQUE	OUTPUT	EFF	CURRENT	TORQUE		
			rpm	A	rpm	A	g-cm	mN-m	W	%	A	g-cm	mN-m
MP5FN-2080-R	6.0-12.0	6.0V CONSTANT	5200	0.16	4000	0.54	41	4.02	1.70	53	2.06	202	19.80
MP5FN-14165-R	6.0-24.0	12.0V CONSTANT	5000	0.07	3920	0.26	43	4.22	1.71	58	1.09	232	22.75
MS5FN-12210-R	12.0-24.0	24.0V CONSTANT	8000	0.08	6313	0.24	60	5.88	3.88	73	0.88	276	27.06
MS5FN-16120-R	12.0-24.0	12.0V CONSTANT	7600	0.10	5800	0.46	48	4.71	2.89	54	1.70	235	23.04

馬達的出軸長度及性能參數，EMC 對策可依客人要求做調整，詳情可詢問相關業務人員。  
Please inquire your sales representative for output, performance and EMC solution.

