

Application : Warning Light 、 Drill & Screwdriver

用途：警示燈、電動工具

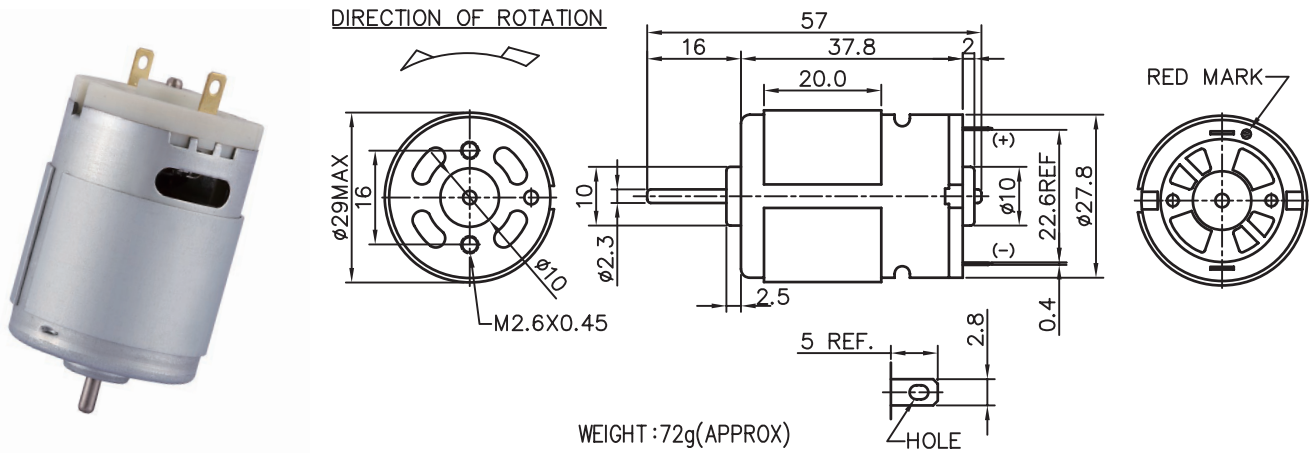

MODEL	VOLTAGE		NO LOAD		AT MAXIMUM EFFICIENCY						STALL		
	OPERATING RANGE	NOMNAL	SPEED	CURRENT	SPEED	CURRENT	TORQUE	OUTPUT	EFF	CURRENT	TORQUE		
			rpm	A	rpm	A	g-cm	mN-m	W	%	A	g-cm	mN-m
LS3N-2870-R	6.0 - 12.0	7.2V CONSTANT	10400	0.32	8400	1.73	94	9.21	8.28	66	7.88	520	50.98
LS3N-3558-R	3.0 - 7.2	6.0V CONSTANT	10500	0.40	8800	2.20	98	9.61	8.93	68	12.60	668	65.49
LP3N-14350-R	6.0 - 12.0	12.0V CONSTANT	3200	0.06	2600	0.21	57	5.20	1.43	57	0.83	263	25.78
LP3N-18200-R	6.0 - 12.0	6.0V CONSTANT	3000	0.08	2400	0.23	61	2.84	0.74	61	1.12	195	19.11

馬達的出軸長度及性能參數，EMC 對策可依客人要求做調整，詳情可詢問相關業務人員。
Please inquire your sales representative for output, performance and EMC solution.

