

Application : Car Window Shade 、Printer 、Pump 、Drill & Screwdriver

用途：汽車遮陽簾、印表機、泵浦、電動工具

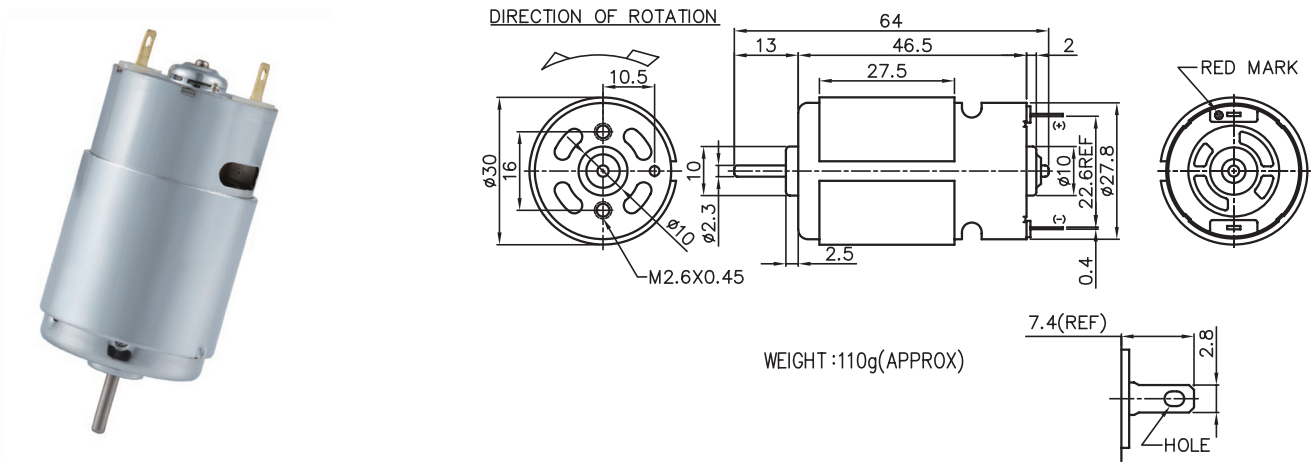

MODEL	VOLTAGE		NO LOAD		AT MAXIMUM EFFICIENCY						STALL		
	OPERATING RANGE	NOMNAL	SPEED	CURRENT	SPEED	CURRENT	TORQUE	OUTPUT	EFF	CURRENT	TORQUE		
			rpm	A	rpm	A	g-cm	mN-m	W	%	A	g-cm	mN-m
JD5FN-2275-R	12.0-24.0	12.0V CONSTANT	5000	0.14	4177	0.55	103	10.10	4.42	68	3.23	724	70.98
JD5FN-3039F-R	6.0-24.0	24.0V CONSTANT	19600	0.52	16784	2.38	250	24.51	43.05	76	15.82	1909	187.16
JD5FN-2466-R	12.0-36.0	30.0V CONSTANT	15700	0.18	13900	1.12	173	16.96	24.89	77	9.07	1655	162.25
JD5FN-2552-R-NF	12.0-24.0	18.0V CONSTANT	12500	0.32	10650	1.51	176	17.25	19.23	70	8.08	1098	107.65

馬達的出軸長度及性能參數，EMC 對策可依客人要求做調整，詳情可詢問相關業務人員。  
Please inquire your sales representative for output, performance and EMC solution.

