

Application : Vending Machine 、 Power antenna 、 Electric Screwdriver

用途 : 自動販賣機、電動天線、電動螺絲起子

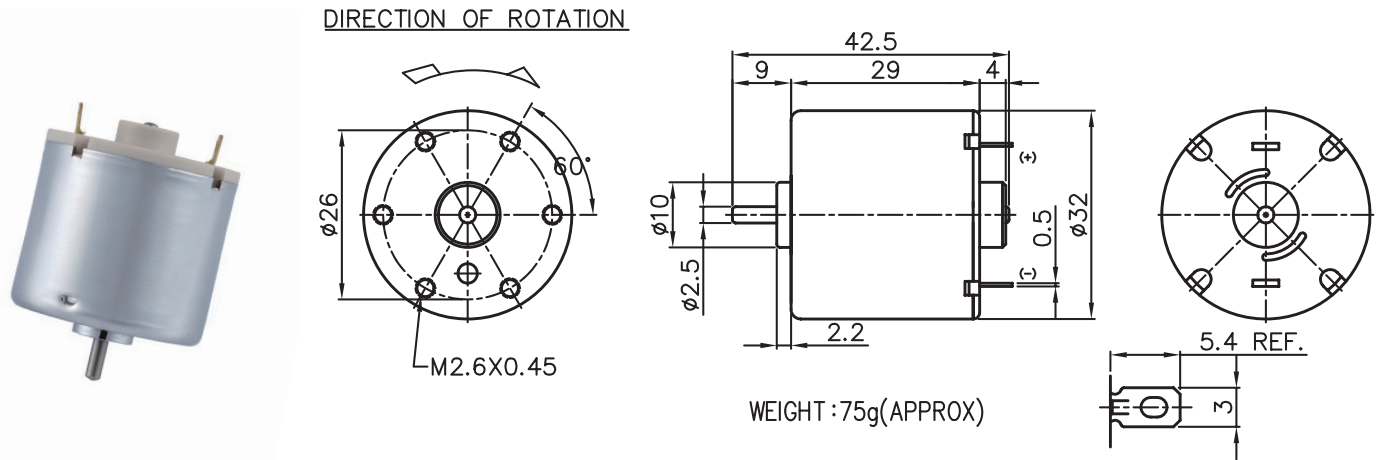

MODEL	VOLTAGE		NO LOAD		AT MAXIMUM EFFICIENCY						STALL		
	OPERATING RANGE	NOMNAL	SPEED	CURRENT	SPEED	CURRENT	TORQUE	OUTPUT	EFF	CURRENT	TORQUE		
			rpm	A	rpm	A	g-cm	mN-m	W	%	A	g-cm	mN-m
GR-3548-R	1.2 - 3.6	2.4V CONSTANT	6400	0.60	5000	2.15	54.55	5.35	2.80	54.27	7.70	250	24.51
GR-14475-R	12.0-24.0	12.0V CONSTANT	3400	0.06	2944	0.14	30.05	2.95	0.91	61.00	0.76	242	23.73
GR-20240-R	6.0-18.0	9.0V CONSTANT	5000	0.14	4021	0.36	45.62	4.47	1.88	64.00	1.82	290	28.43
GR-12530-R	12.0-24.0	24.0V CONSTANT	6200	0.06	5000	0.21	61.76	6.05	3.17	62.31	0.90	320	31.37

馬達的出軸長度及性能參數，EMC 對策可依客人要求做調整，詳情可詢問相關業務人員。
Please inquire your sales representative for output, performance and EMC solution.

