

Application : Drill & Screwdriver 、 Tire Pump 、 Power antenna 、 Auto Transformer

用途：電動工具、汽車打氣泵、電動天線、自動變壓器

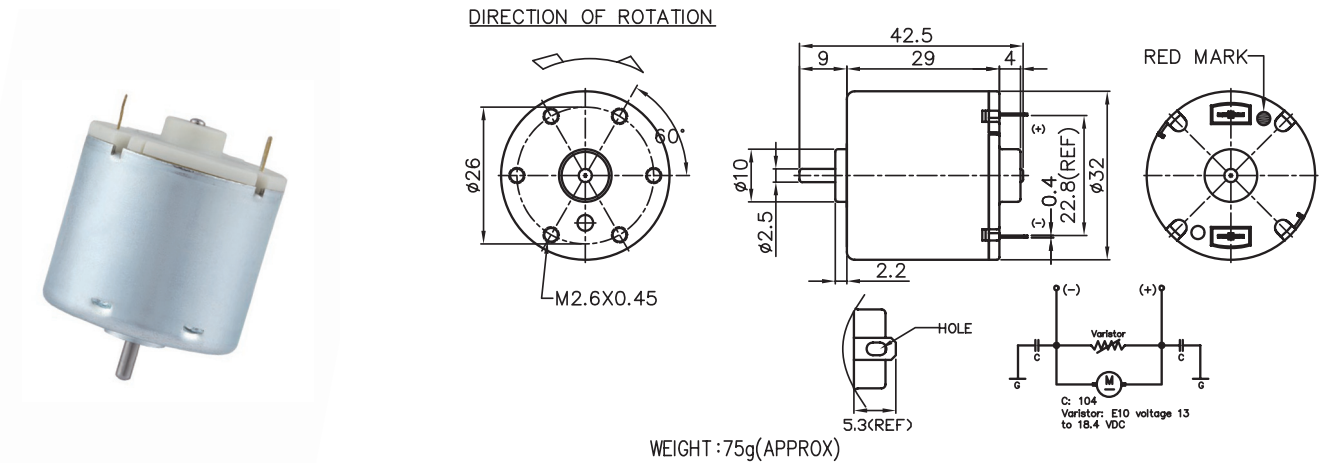

MODEL	VOLTAGE		NO LOAD		AT MAXIMUM EFFICIENCY						STALL		
	OPERATING RANGE	NOMNAL	SPEED	CURRENT	SPEED	CURRENT	TORQUE	OUTPUT	EFF	CURRENT	TORQUE		
			rpm	A	rpm	A	g-cm	mN-m	W	%	A	g-cm	mN-m
GRD-12500-R	12.0-24.0	24.0V CONSTANT	6200	0.12	4958	0.27	73.67	7.22	3.75	61.31	1.19	411	40.29
GRD-26125-R	3.0-9.0	9.0V CONSTANT	9500	0.40	7746	1.39	97.96	9.60	7.79	64.00	7.55	637	62.45
GRD-15450-R	12.0-24.0	12.0V CONSTANT	3400	0.09	2851	0.24	45.89	4.50	1.34	52.08	1.08	273	26.76
GRD-16350-R	12.0-24.0	12.0V CONSTANT	4500	0.13	3574	0.34	65.11	6.38	2.39	61.25	1.48	333	32.65

馬達的出軸長度及性能參數，EMC 對策可依客人要求做調整，詳情可詢問相關業務人員。
Please inquire your sales representative for output, performance and EMC solution.

