

Application : R/C Car、Drill & Screwdriver、Tire Pump

用途：遙控車、電動工具、汽車打氣泵

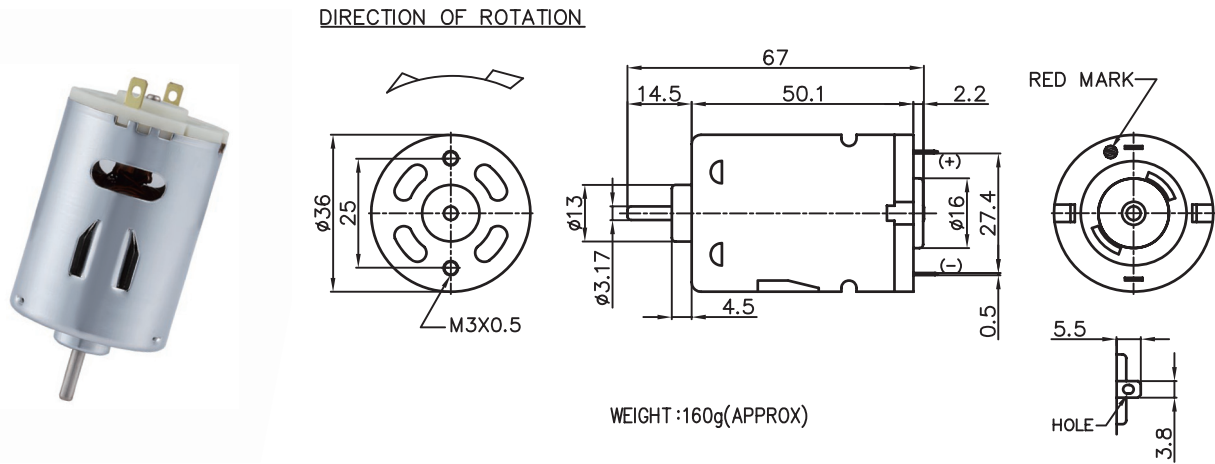

MODEL	VOLTAGE		NO LOAD		AT MAXIMUM EFFICIENCY						STALL		
	OPERATING RANGE	NOMNAL	SPEED	CURRENT	SPEED	CURRENT	TORQUE	OUTPUT	EFF	CURRENT	TORQUE		
			rpm	A	rpm	A	g-cm	mN-m	W	%	A	g-cm	mN-m
HS3SN-4070-R	6.0 - 12.0	12.0V CONSTANT	11000	0.50	9300	2.87	235	23.04	22.58	65	16.46	1580	154.90
HS3SN-22240-R	12.0 - 24.0	12.0V CONSTANT	3000	0.11	2300	0.56	162	15.88	3.84	58	2.07	695	68.14
HP3SN-5048-R	6.0 - 12.0	12.0V CONSTANT	16200	0.86	13800	5.38	312	30.59	44.34	69	32.55	2186	214.31
HP3SN-26135-R	12.0 - 24.0	12.0V CONSTANT	5400	0.20	4400	0.98	163	15.98	7.50	65	5.43	1081	105.98

馬達的出軸長度及性能參數，EMC 對策可依客人要求做調整，詳情可詢問相關業務人員。
Please inquire your sales representative for output, performance and EMC solution.

