

# RK-525

## Carbon-brush motors

Application : Drill & Screwdriver 、 Gamepads 、 Vending Machine

用途：電動工具、電玩手把、自動販賣機

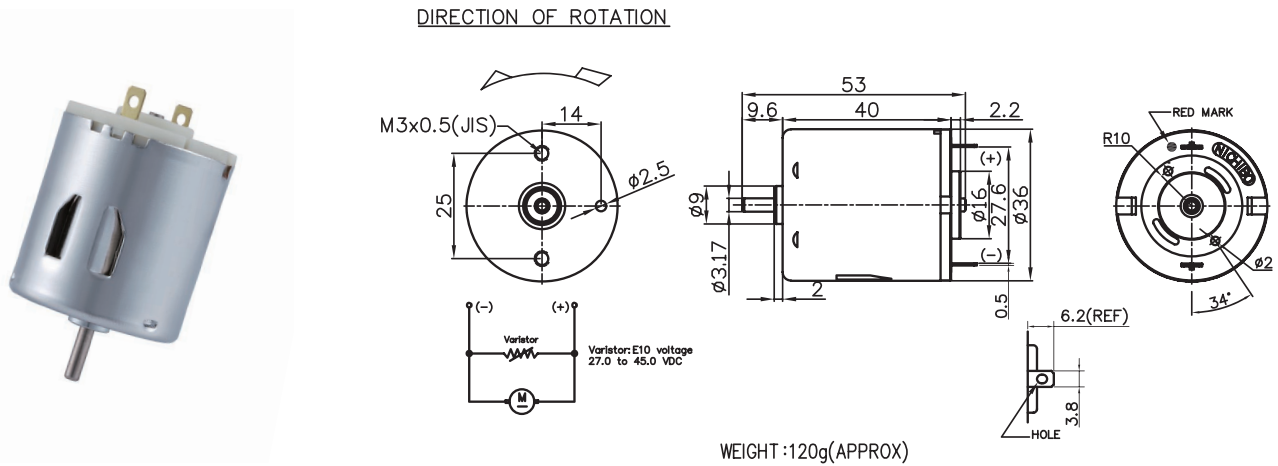

MODEL	VOLTAGE		NO LOAD		AT MAXIMUM EFFICIENCY					STALL			
	OPERATING RANGE	NOMNAL	SPEED rpm	CURRENT A	SPEED rpm	CURRENT A	TORQUE g-cm	OUTPUT mN-m	EFF W	%	CURRENT A	TORQUE g-cm	TORQUE mN-m
RK-525B-15180S-R	6.0 - 36.0	24.0V CONSTANT	5700	0.11	4613	0.39	118	11.57	5.59	63	1.81	688	67.45
RK-525B-2480-R	6.0 - 36.0	12.0V CONSTANT	6450	0.42	5131	0.96	136	13.33	7.15	64	4.21	727	71.72
RK-525-15245-R	12.0 - 36.0	24.0V CONSTANT	4000	0.06	3305	0.27	116	11.37	3.93	64	1.26	666	65.29
RK-525B-22125-R	6.0 - 24.0	12.0V CONSTANT	4000	0.20	3226	0.59	127	12.45	4.20	60	2.63	704	69.02

馬達的出軸長度及性能參數，EMC 對策可依客人要求做調整，詳情可詢問相關業務人員。  
Please inquire your sales representative for output, performance and EMC solution.

