

Application : Air Compressor 、 Drill & Screwdriver

用途 : 空壓機、電動工具

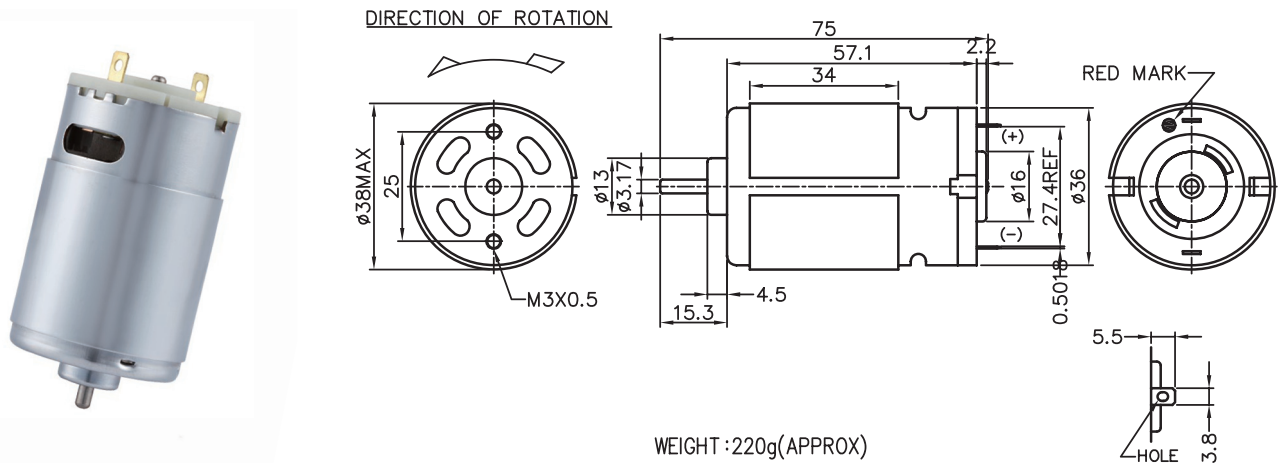

MODEL	VOLTAGE		NO LOAD		AT MAXIMUM EFFICIENCY						STALL		
	OPERATING RANGE	NOMNAL	SPEED	CURRENT	SPEED	CURRENT	TORQUE	OUTPUT	EFF	CURRENT	TORQUE		
			rpm	A	rpm	A	g-cm	mN-m	W	%	A	g-cm	mN-m
KD3N-26150-R	12.0 - 24.0	12.0V CONSTANT	3400	0.16	2788	0.68	192	8.82	5.50	70	3.85	1288	126.27
KP3N-4075-R	6.0 - 12.0	12.0V CONSTANT	7250	0.38	6494	1.65	209	20.49	13.95	71	15.36	2202	215.88
KP3N-7521-R	4.8 - 12.0	7.2V CONSTANT	14500	1.50	12700	9.89	390	38.24	51.24	72	79.81	3608	353.73
KP3N-35110-R	6.0 - 24.0	12.0V CONSTANT	4500	0.15	3800	1.14	242	23.73	9.61	71	8.33	2020	198.04

馬達的出軸長度及性能參數，EMC 對策可依客人要求做調整，詳情可詢問相關業務人員。
Please inquire your sales representative for output, performance and EMC solution.

