

Application : Massager 、 Drill & Screwdriver

用途 : 電動按摩器、電動工具

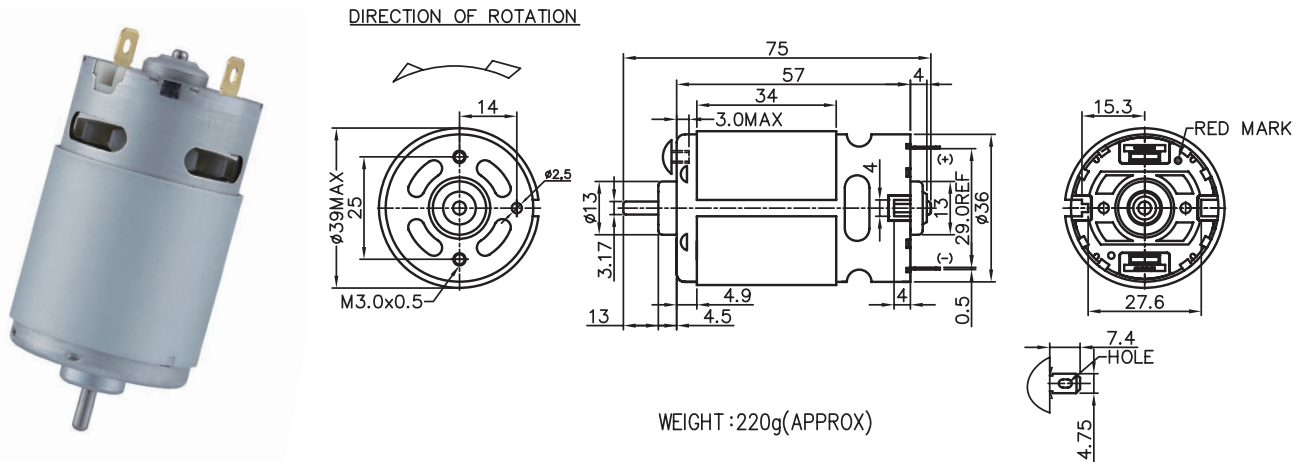

MODEL	VOLTAGE		NO LOAD		AT MAXIMUM EFFICIENCY					STALL			
	OPERATING RANGE	NOMNAL	SPEED	CURRENT	SPEED	CURRENT	TORQUE	OUTPUT	EFF	CURRENT	TORQUE		
			rpm	A	rpm	A	g-cm	mN-m	W	%	A	g-cm	mN-m
KV3SFN-8521F-WR	6.0 - 12.0	12.0V CONSTANT	22500	2.70	19048	18.33	853	83.63	312.68	77	98.00	5394	528.82
KV3SFN-7527F-WR	6.0 - 18.0	18.0V CONSTANT	25000	2.10	21692	13.16	773	75.78	379.91	74	87.59	5958	584.12
KV3SFN-8520SF-WR	6.0 - 12.0	10.8V CONSTANT	21500	3.20	17091	22.67	1013	99.31	307.00	76	106.54	5768	565.49
KBV3SFN-70x2T14F-WR	6.0 - 12.0	12.0V CONSTANT	32000	5.40	24675	38.19	1236	121.18	569.43	72	193.64	7509	736.18

馬達的出軸長度及性能參數，EMC 對策可依客人要求做調整，詳情可詢問相關業務人員。  
Please inquire your sales representative for output, performance and EMC solution.

