

Application : Seat Belt Pretensioner、Drill & Screwdriver、Printer、Massager

用途：安全帶捲帶器、電動工具、印表機、電動按摩器

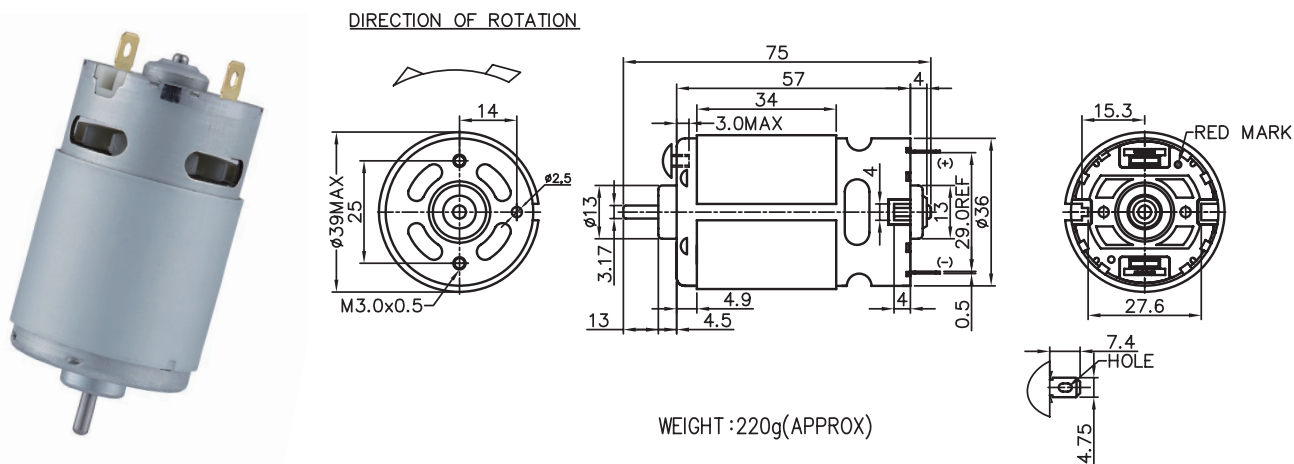

WEIGHT : 220g(APPROX)

MODEL	VOLTAGE		NO LOAD		AT MAXIMUM EFFICIENCY					STALL			
	OPERATING RANGE	NOMNAL	SPEED rpm	CURRENT A	SPEED rpm	CURRENT A	TORQUE g-cm	OUTPUT mN-m	EFF W	%	CURRENT A	TORQUE g-cm	TORQUE mN-m
KD5FN-2872-R	12.0-24.0	12.0V CONSTANT	3400	0.14	3055	0.64	181	17.75	5.67	75	4.29	1433	140.49
KD5FN-6014SF-R	12.0-18.0	18.0V CONSTANT	28000	2.50	24038	14.49	759	74.41	187.37	72	81.47	5252	514.90
KV5FN-5521F-WR	6.0-24.0	18.0V CONSTANT	17500	1.50	15974	5.94	514	50.39	81.96	82	51.43	5319	521.47
KV5FN-5518F-WR	12.0-18.0	14.4V CONSTANT	15600	1.60	13889	7.98	610	59.8	77.57	78	50.80	4725	463.24

馬達的出軸長度及性能參數，EMC 對策可依客人要求做調整，詳情可詢問相關業務人員。
Please inquire your sales representative for output, performance and EMC solution.

