

K5FN-IE

Carbon-brush motors

Application : Drill & Screwdriver

用途：電動工具

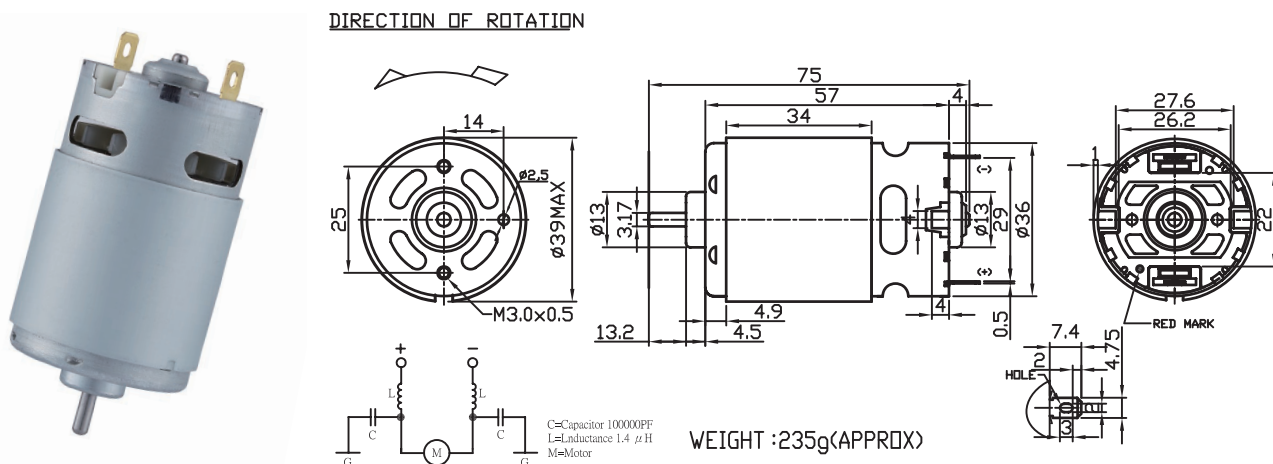

MODEL	VOLTAGE		NO LOAD		AT MAXIMUM EFFICIENCY						STALL		
	OPERATING RANGE	NOMINAL	SPEED rpm	CURRENT A	SPEED rpm	CURRENT A	TORQUE g-cm	OUTPUT mN-m	EFF %	CURRENT A	TORQUE mN-m		
KS5FN-18150-CE-IE	12.0 - 36.0	16.0V CONSTANT	2300	0.09	2067	0.16	81	7.94	1.71	72	1.34	849	83.24
KP5BFN-22110-CE-IE	12.0 - 36.0	15.0V CONSTANT	2900	0.09	2483	0.39	151	14.80	3.85	68	2.38	1090	106.86
KV5FN-5021F-CE-IE	12.0 - 18.0	14.4V CONSTANT	14000	0.83	12077	6.13	562	55.10	69.70	81	43.23	4458	437.06
KV5FN-6015SF-CE-IE	12.0 - 18.0	14.4V CONSTANT	18200	1.26	16129	9.82	655	64.22	108.49	79	70.81	5548	543.92

馬達的出軸長度及性能參數，EMC 對策可依客人要求做調整，詳情可詢問相關業務人員。
Please inquire your sales representative for output, performance and EMC solution.

