

RK-665

Carbon-brush motors

Application : Drill & Screwdriver 、 Gamepads

用途：電動工具、電玩手把



DIRECTION OF ROTATION

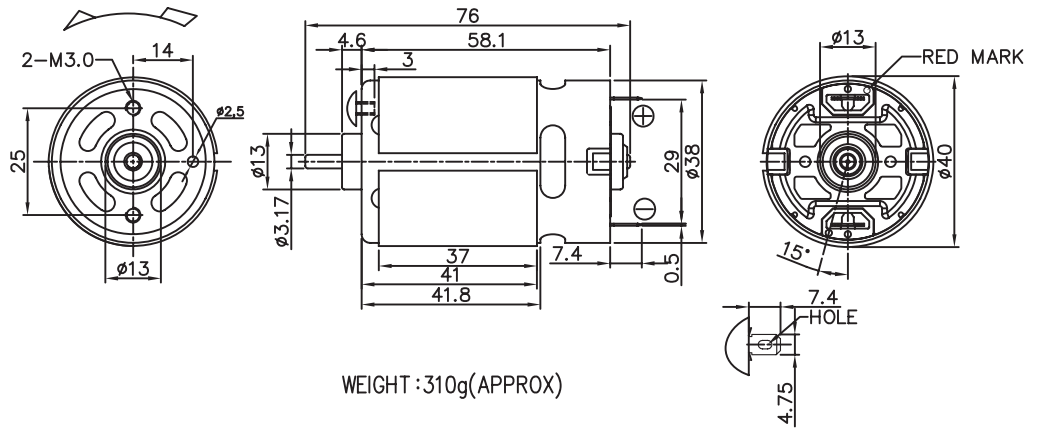

WEIGHT : 310g(APPROX)

MODEL	VOLTAGE		NO LOAD		AT MAXIMUM EFFICIENCY					STALL			
	OPERATING RANGE	NOMNAL	SPEED rpm	CURRENT A	SPEED rpm	CURRENT A	TORQUE g-cm	OUTPUT W	EFF %	CURRENT A	TORQUE g-cm	TORQUE mN-m	
RK-665-4047-WR	9.0 - 24.0	12.0V CONSTANT	4200	0.40	3566	2.03	456	44.71	16.69	71	13.01	3444	337
RK-665-5524-WR	6.0 - 21.0	18.0V CONSTANT	14000	0.98	11792	6.83	813	79.71	98.45	81	43.76	5746	565
RK-665-6019-WR	6.0 - 21.0	19.8V CONSTANT	18800	1.60	15576	10.49	1040	101.96	166.36	81	69.45	7962	781
RK-665-5522-WR	12.0 - 24.0	24.0V CONSTANT	18000	1.20	15848	8.99	944	92.55	153.64	74	64.61	7648	750

馬達的出軸長度及性能參數，EMC 對策可依客人要求做調整，詳情可詢問相關業務人員。
Please inquire your sales representative for output, performance and EMC solution.

