

RS-800

Carbon-brush motors

Application : Drill & Screwdriver

用途：電動工具

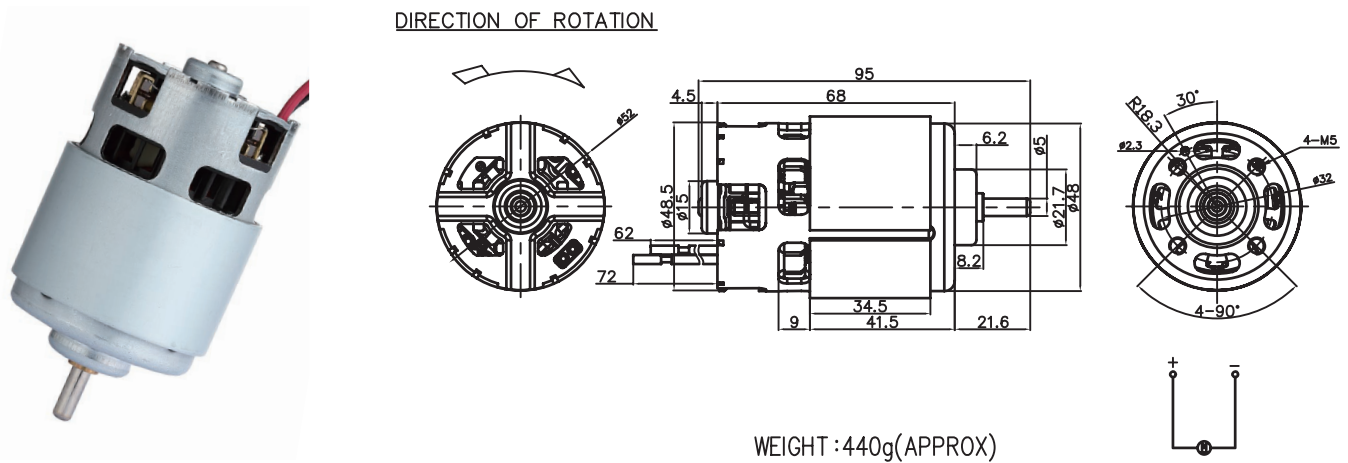

| MODEL | VOLTAGE | | NO LOAD | | AT MAXIMUM EFFICIENCY | | | | | STALL | | | |
|---------------------|-----------------|----------------|---------|---------|-----------------------|---------|--------|--------|--------|---------|--------|-------|---------|
| | OPERATING RANGE | NOMINAL | SPEED | CURRENT | SPEED | CURRENT | TORQUE | OUTPUT | EFF | CURRENT | TORQUE | | |
| | | | rpm | A | rpm | A | g-cm | mN-m | W | % | A | g-cm | mN-m |
| REB-8V10P32-5019F-R | 12.0 - 24.0 | 20.7V CONSTANT | 17200 | 2.83 | 14184 | 17.65 | 1747 | 171.27 | 245.47 | 72 | 110.36 | 12999 | 1274.41 |
| REB-8S11P37-8508F-R | 14.0 - 22.0 | 18.0V CONSTANT | 19300 | 4.80 | 16694 | 40.02 | 3337 | 327.16 | 572.09 | 79 | 265.90 | 25000 | 2450.98 |

馬達的出軸長度及性能參數，EMC 對策可依客人要求做調整，詳情可詢問相關業務人員。
Please inquire your sales representative for output, performance and EMC solution.

