

BL24E14

Brushless DC Motor

Application : Vacuum Robot 、 Fan

用途：智能吸塵機器人、風扇

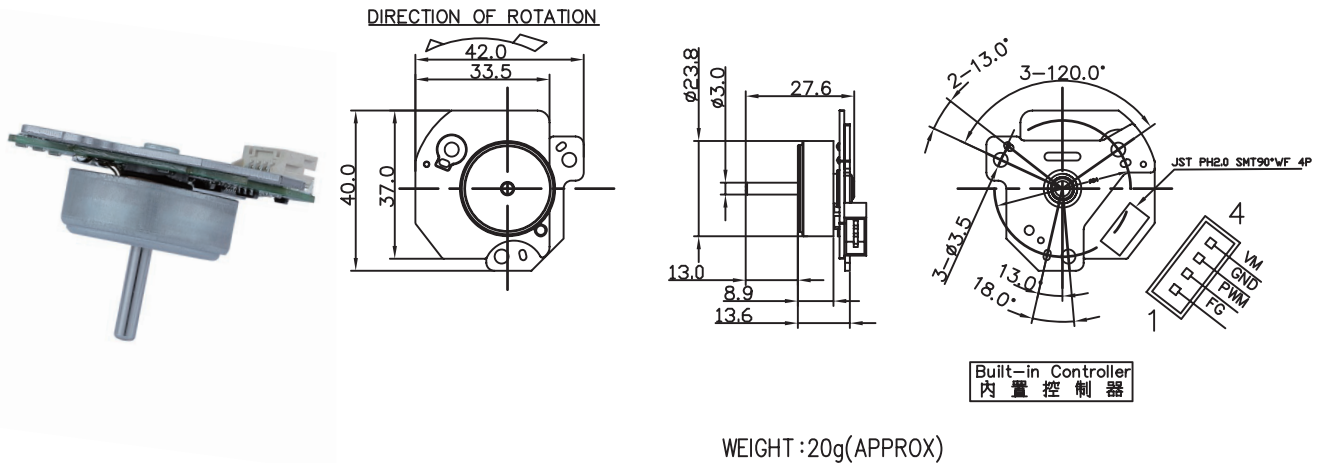

MODEL	VOLTAGE		NO LOAD		AT MAXIMUM EFFICIENCY					STALL			
	OPERATING RANGE	NOMINAL	SPEED rpm	CURRENT A	SPEED rpm	CURRENT A	TORQUE g-cm	TORQUE N-m	OUTPUT W	EFF %	CURRENT A	TORQUE g-cm	TORQUE N-m
BL24E14B-12V16.8K9W-C0Y0P	10.0-16.0	12.0V CONSTANT	17200	0.4	12359	1.62	86.9	8.52	11.04	58	4.92	351.5	34.45
BL24E14B-12V23.7K20W-C0Y0P	10.0-16.0	12.0V CONSTANT	24000	0.48	20200	2.05	62.2	6.09	12.90	59	8.90	375.1	36.76

馬達的出軸長度及性能參數，EMC 對策可依客人要求做調整，詳情可詢問相關業務人員。
Please inquire your sales representative for output, performance and EMC solution.

