

Application : Automatic Feeder 、 Hair Dryer

用途 : 自動餵食器、吹風機

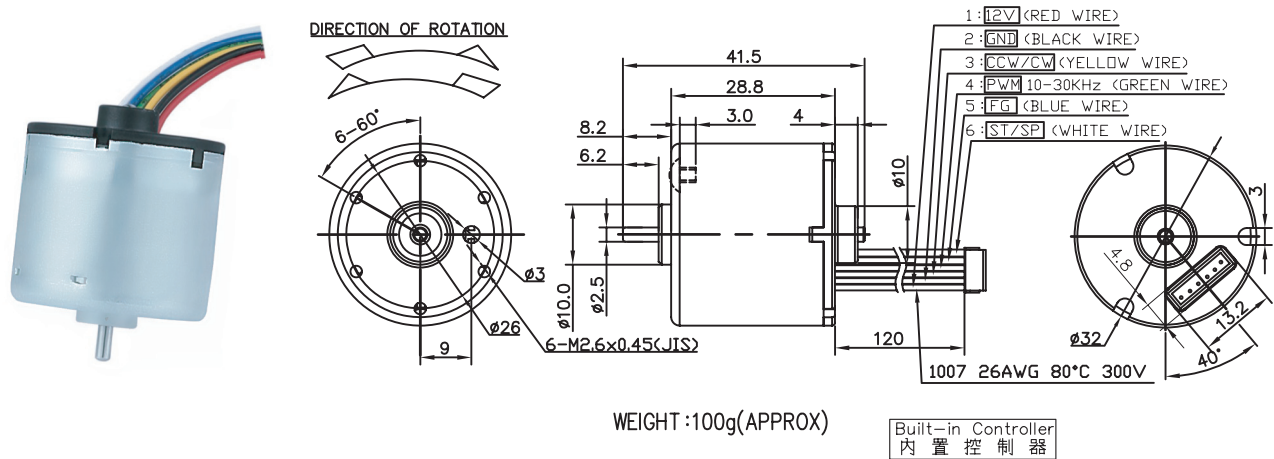

MODEL	VOLTAGE		NO LOAD		AT MAXIMUM EFFICIENCY					STALL			
	OPERATING RANGE	NOMINAL	SPEED	CURRENT	SPEED	CURRENT	TORQUE	OUTPUT	EFF	CURRENT	TORQUE		
			rpm	A	rpm	A	g-cm	mN-m	W	%	A	g-cm	mN-m
BL3229B-24V6.0K4.0W-B0X0N	9.0-30.0	24.0V CONSTANT	6000	0.72	4864	0.39	90.42	8.86	4.52	65	1.45	499.32	48.95
BL3229B-12V4.0K2.5W-C1Y1P	9.0-30.0	12.0V CONSTANT	4000	0.70	3053	0.36	89.96	8.82	2.82	66	1.42	409.56	40.15
BL3229B-24V4.0K2.0W-B1X0N	9.0-30.0	24.0V CONSTANT	4000	0.05	3126	0.17	66.04	6.04	2.12	56	0.56	290.30	28.46
BL3229B-12V10.0K9W-C1Y1P	9.0-30.0	12.0V CONSTANT	10200	0.18	9107	1.03	98.17	9.62	9.18	76	8.14	916.81	89.88

馬達的出軸長度及性能參數，EMC 對策可依客人要求做調整，詳情可詢問相關業務人員。
Please inquire your sales representative for output, performance and EMC solution.

