

# BL3640

Brushless DC Motor

Application : Gear Motor 、 Pump 、 Robot

用途 : 齒輪箱、泵浦、機器人

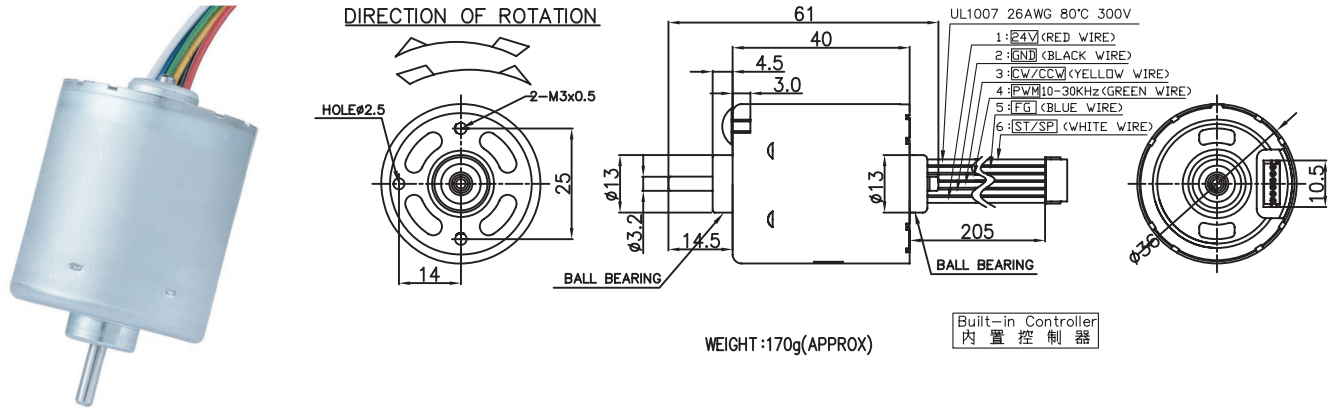

MODEL	VOLTAGE		NO LOAD		AT MAXIMUM EFFICIENCY					STALL			
	OPERATING RANGE	NOMINAL	SPEED rpm	CURRENT A	SPEED rpm	CURRENT A	TORQUE g-cm	TORQUE mN-m	OUTPUT W	EFF %	CURRENT A	TORQUE g-cm	TORQUE mN-m
BL3640B-12V8.0K14W-B1X0N	10.0-30.0	12.0V CONSTANT	8000	0.42	6596	2.05	212	20.78	14.36	62	9.69	1287	126.18
BL3640B-24V9.0K23W-C1Y1P	10.0-30.0	24.0V CONSTANT	9000	0.17	7675	1.38	295	28.92	23.25	74	7.37	1859	182.25

馬達的出軸長度及性能參數，EMC 對策可依客人要求做調整，詳情可詢問相關業務人員。  
Please inquire your sales representative for output, performance and EMC solution.

