

BL3649

Brushless DC Motor

Application : Gear Motor、Pump、Robot

用途：齒輪箱、泵浦、機器人

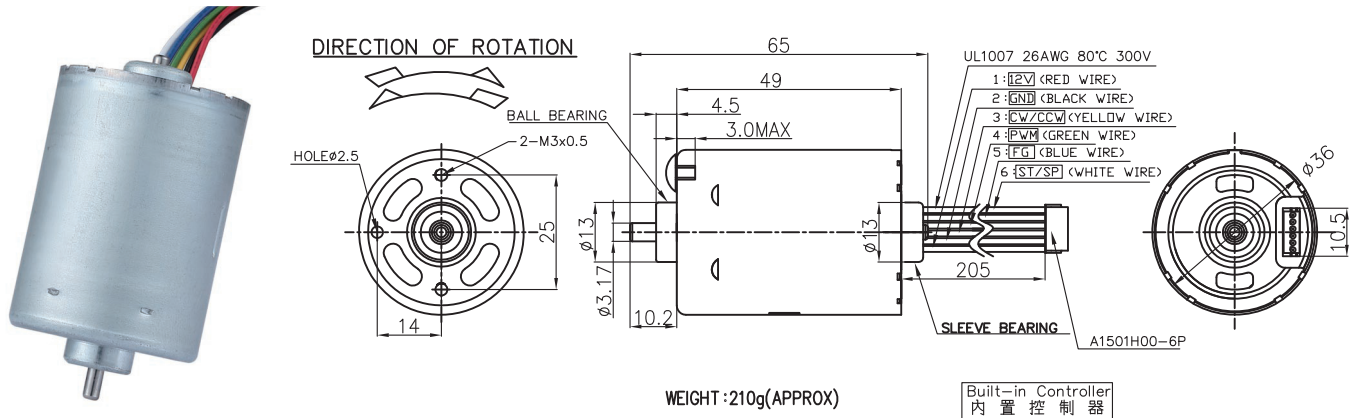

MODEL	VOLTAGE		NO LOAD		AT MAXIMUM EFFICIENCY					STALL			
	OPERATING RANGE	NOMINAL	SPEED rpm	CURRENT A	SPEED rpm	CURRENT A	TORQUE g-cm	OUTPUT mN-m	EFF %	CURRENT A	TORQUE g-cm	TORQUE mN-m	
BL3649B-24V5.0K13W-B1X0N	10.0-30.0	24.0V CONSTANT	5000	0.16	4484	0.72	286	28.04	13.17	81	5.23	2379	233.24
BL3649B-12V3.5K7.0W-C1Y1P	10.0-30.0	12.0V CONSTANT	3500	0.16	3135	0.85	242	23.73	7.79	78	6.04	1936	189.80

馬達的出軸長度及性能參數，EMC 對策可依客人要求做調整，詳情可詢問相關業務人員。
Please inquire your sales representative for output, performance and EMC solution.

