

BL3657

Brushless DC Motor

Application : Gear Motor 、 Pump 、 Electric Fan 、 Bubble Wrap Machine

用途：齒輪箱、泵浦、風扇、氣泡布製造機

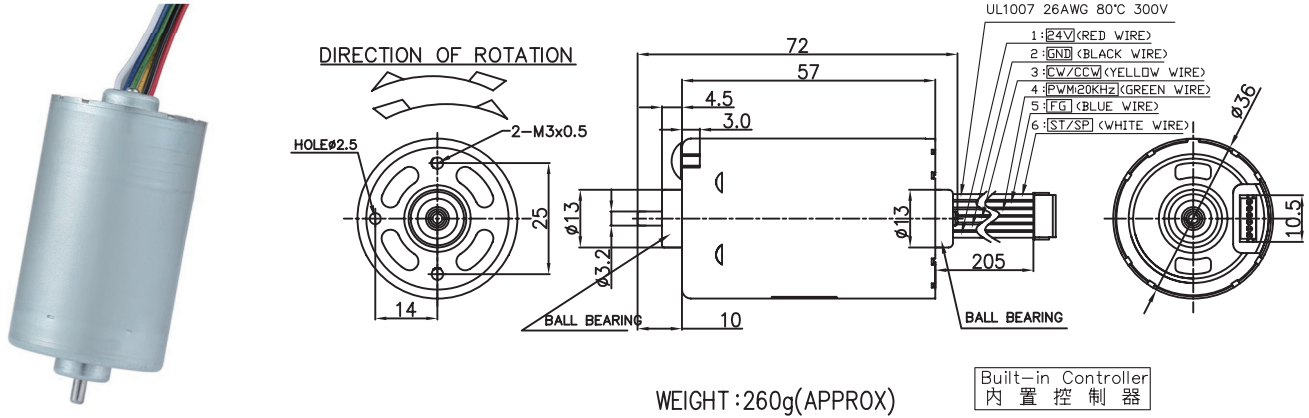

MODEL	VOLTAGE		NO LOAD		AT MAXIMUM EFFICIENCY					STALL			
	OPERATING RANGE	NOMINAL	SPEED rpm	CURRENT A	SPEED rpm	CURRENT A	TORQUE g-cm	OUTPUT mN-m	EFF W	CURRENT %	CURRENT A	TORQUE g-cm	TORQUE mN-m
BL3657B-12V2.7K5.0W-B1X0N	10.0-30.0	12.0V CONSTANT	2700	0.15	2408	0.65	217.6	21.33	5.38	74	4.05	1662.2	162.96
BL3657B-24V9.0K35W-C1Y1P	10.0-30.0	24.0V CONSTANT	9000	0.35	7786	2.16	458.9	44.99	36.69	76	11.78	2952.1	289.42

馬達的出軸長度及性能參數，EMC 對策可依客人要求做調整，詳情可詢問相關業務人員。
Please inquire your sales representative for output, performance and EMC solution.

