

BL16E25

Brushless DC Motor

Application : Mobile Relay Station

用途 : 基站

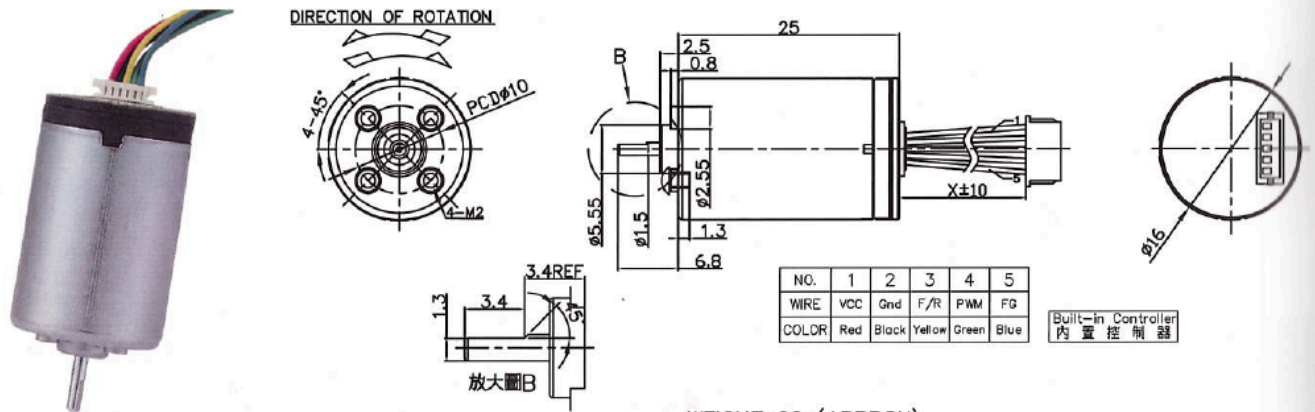

WEIGHT : 20g (APPROX)

MODEL	VOLTAGE		NO LOAD		AT MAXIMUM EFFICIENCY						STALL		
	OPERATING RANGE	NOMINAL	SPEED	CURRENT	SPEED	CURRENT	TORQUE		OUTPUT	EFF	CURRENT	TORQUE	
			rpm	A	rpm	A	Kg-cm	N-m	W	%	A	Kg-cm	N-m
BL16E25B-12V9.5K1W-C0Y1P	9.0-12.0	12.0V CONSTANT	8100	48	6580	0.33	24.8	2.43	1.7	45	0.96	103	10.1
BL16E25B-9V13.5K2.8W-C0Y1P	9.0-12.0	9.0V CONSTANT	13500	100	11100	0.53	25.0	2.45	2.8	62	3.00	160	15.7

