

步进伺服电机 Closed-Loop Stepper Motor

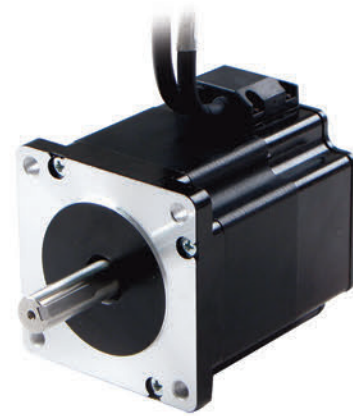

机械尺寸 (Dimension)

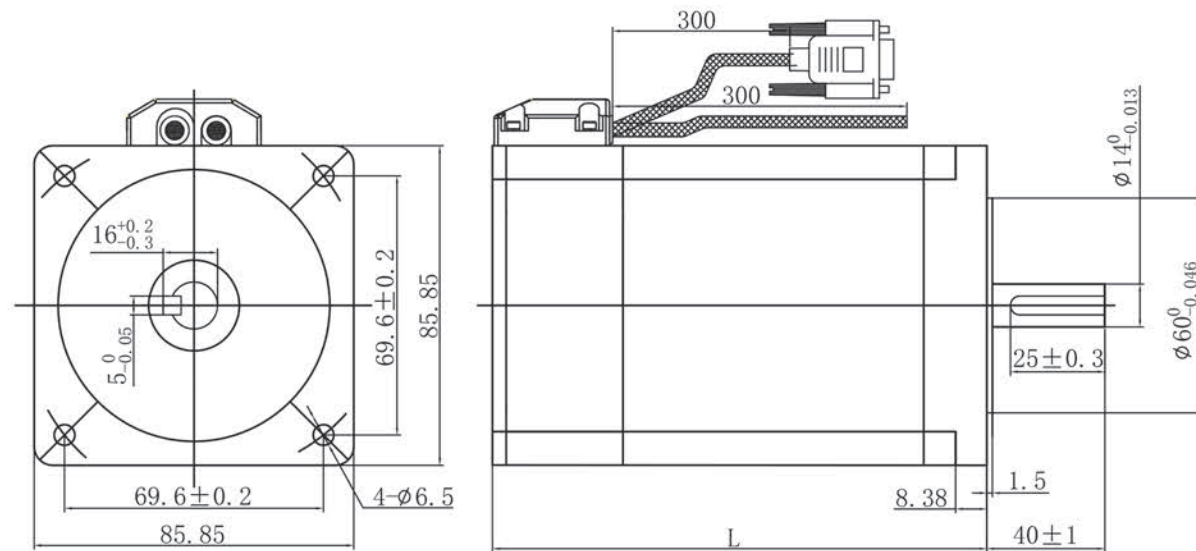

性能曲线 (Performance Curve)

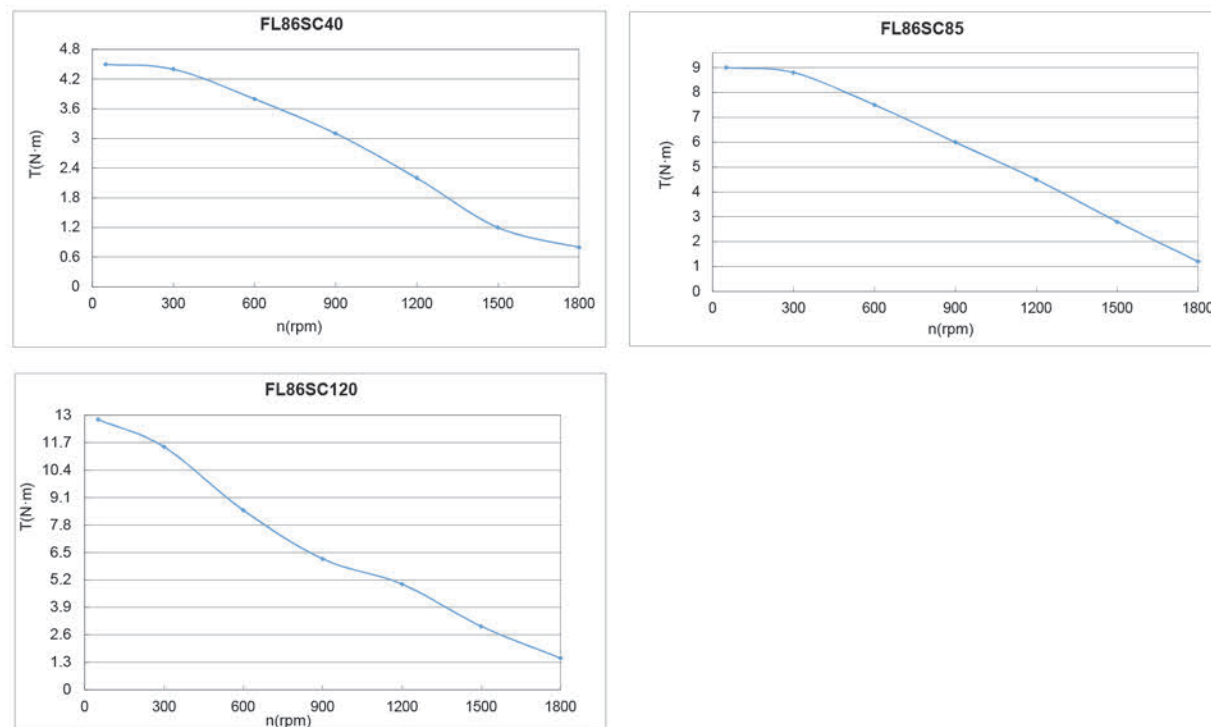

一般技术特性 (General Technical Information)

编码器类型 (Encoder type)	1、光电编码器 Optical encoder 2、磁编码器 Magnetic encoder 3、旋转变压器 Resolver 备注：多种分辨率可选，增量式、绝对值式可选。 Note: Multiple resolutions are available ; Incremental or absolute encoders are optional.		
径向负载 (Max radial force)	130N@20mm from the flange	环境条件 Environmental conditions	使用环境温度：-20°C~+40°C ; Temperature: -20°C~+40°C 使用环境湿度：≤90%RH (无凝露) ; Relative humidity: ≤90%RH(No dewing) 安装环境：远离腐蚀、可燃性气体，油滴，灰尘， 海拔≤1000m(1000~4000m，降额使用) ; Installation environment: Far away active gas, Combustible gas, oil drop, ash. altitude≤1000m(1000~4000m，Derating use) ; 存储环境：-20°C~+60°C，≤85%RH (无凝露) ; Storage Condition: -20°C~+60°C，≤85%RH(No dewing).
轴向负载 (Max axial force)	36N		
绝缘等级 (Insulation Class)	B		
防护等级 (Protection level)	IP30		

电机技术性能 (Motor Technical Specification)

	单位(Unit)	FL86SC40	FL86SC85	FL86SC120
相电流 (Phase current)	A	6	6	6
保持转矩 (Holding torque)	N·m	4	8.5	12
最高转速 (Speed)	rpm	1800	1800	1800
编码器 (Encoder)		1000cpr 光电增量式编码器 1000cpr incremental optical encoder		
转动惯量 (Rotor inertia)	g·cm ²	1400	2700	4000
机身长度 (Motor Length) L	mm	96	133	171
重量 (Weight)	Kg	2.5	3.8	5.5

接线说明 (Electric Connection)

序号 No.	引出线颜色 Lead Color	引出线型号 Lead Gauge	功能 Function	说明 Description
3	红白色(Red/White)	Three rows of 15PIN D-SUB	GND	Signal Power negative
2	红色(Red)		VCC:+5VDC	Signal Power positive
13	蓝色(Blue)		EA-	Two-channel differential signal (Three-channel differential signal can be provided).
1	蓝黑色(Blue/Black)		EA+	
12	黑色(Black)		EB-	
11	黑白色(Black/White)	EB+		
1	黄色(Yellow)	YGZF-S 4*0.75 Cable	A 相(Phase A)	
2	绿色(Green)		C 相(Phase C)	
3	红色(Red)		B 相(Phase B)	
4	黑色(Blake)		D 相(Phase D)	

编码器接线定义请向富兴机电公司咨询
Please ask for the encoder connection from FULLING MOTOR company

该款电机可以根据客户需求定制。
The motor can be designed & manufactured with customized request.