

直流无刷伺服电机 Closed-Loop Brushless DC Motor

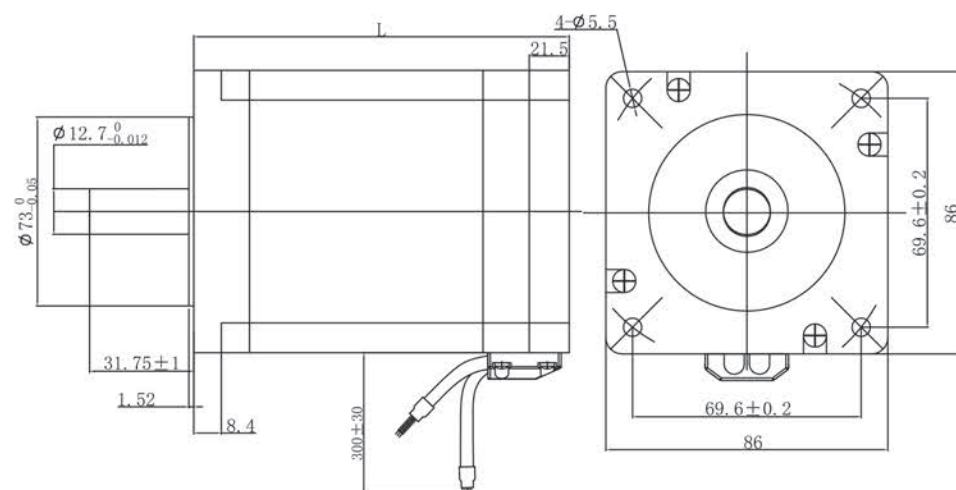

机械尺寸 (Dimension)



性能曲线 (Performance Curve)

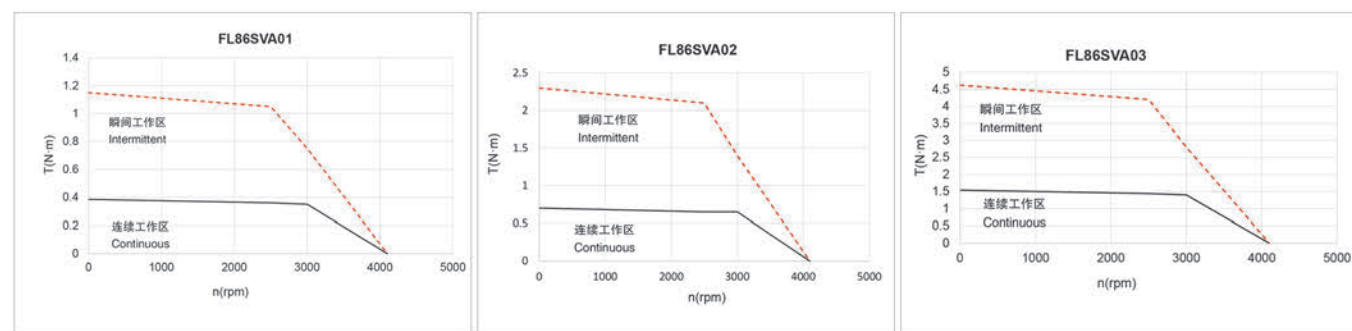

接线说明 (Electric Connection)

序号 No.	引出线颜色 Lead Color	引出线型号 Lead Gauge	功能 Function	说明 Description
1	红白色(Red/White)	Cable AWG26	GND	Signal Power negative
2	红色(Red)		VCC:+5VDC	Signal Power positive
3	蓝色(Blue)		EA-	Two-channel differential signal (Three-channel differential signal can be provided).
4	蓝黑色(Blue/Black)		EA+	
5	黑色(Black)		EB-	
6	黑白色(Black/White)		EB+	
7	棕色(Brown)		霍尔 HALL A	
8	橙色(Orange)		霍尔 HALL B	
9	黄色(Yellow)		霍尔 HALL C	
1	黄色(Yellow)	Cable AWG18	U相(Phase U)	
2	红色(Red)		V相(Phase V)	
3	黑色(Black)		W相(Phase W)	

编码器接线定义请向富兴机电公司咨询
Please ask for the encoder connection from FULLING MOTOR company

一般技术特性 (General Technical Information)

编码器类型 (Encoder type)	1、光电编码器 Optical encoder 2、磁编码器 Magnetic encoder 3、旋转变压器 Resolver 备注：多种分辨率可选，增量式、绝对值式可选。 Note: Multiple resolutions are available ; Incremental or absolute encoders are optional.		
径向负载 (Max radial force)	200N@20mm from the flange	环境条件 Environmental conditions	使用环境温度：-20°C~ +40°C ; Temperature: -20°C~ +40°C 使用环境湿度：≤90%RH (无凝露) ; Relative humidity: ≤90%RH(No dewing) 安装环境：远离腐蚀、可燃性气体，油滴，灰尘， 海拔≤1000m(1000~4000m，降额使用) ; Installation environment: Far away active gas, Combustible gas, oil drop, ash. altitudes≤1000m(1000~4000m, Derating use) ; 存储环境：-20°C~ +60°C , ≤85%RH (无凝露) 。 Storage Condition: -20°C~ +60°C , ≤85%RH(No dewing).
轴向负载 (Max axial force)	65N		
绝缘等级 (Insulation Class)	B		
防护等级 (Protection level)	IP30		

电机技术性能 (Motor Technical Specification)

	单位(Unit)	FL86SVA01	FL86SVA02	FL86SVA03
额定电压(Rated voltage)	VDC	48		
额定转速(Rated speed)	RPM	3000		
额定转矩(Rated torque)	N·m	0.35	0.7	1.4
额定电流(Rated current)	A	3	5.6	11
空载转速(no load speed)	RPM	3600		
峰值扭矩(Peak torque)	N·m	1.05	2.1	4.2
峰值电流(Peak current)	A	9.5	17.5	33.5
电阻(Line to line resistance)	Ω	0.09	0.34	0.16
电感(Line to line inductance)	mH	2.6	1	0.5
反电势系数(Back EMF)	V/Krpm	8.6	9	9.4
转矩系数(Torque constant)	Nm/A	0.116	0.124	0.127
极数(Number of poles)		8		
编码器(Encoder)	CPR	1000		
转动惯量(Rotor inertia)	g.cm ²	400	800	1600
机身长度 L(Motor length)	mm	86	99	126
重量(Weight)	Kg	1.9	2.4	3.5

该款电机可以根据客户需求定制。
The motor can be designed & manufactured with customized request.