

NEW-FLOW

**ISO 9001
REGISTERED**

NEW-FLOW

MANUFACTURE OF ACRYLIC PLASTIC FLOW METER
FAC-200 SERIES
AND CONTROL INSTRUMENTS

Instruction Manual

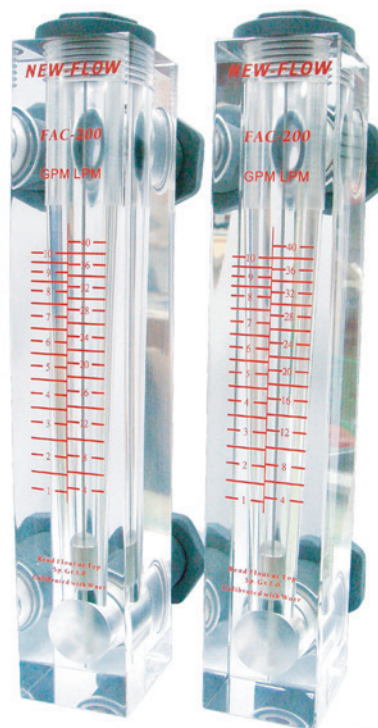

Approvals:



FAC200

NEW-FLOW TECHNOLOGIES, INC.

No.9 Lane 133, Xing-Hua St., Chien Chen Dist., Kaohsiung 806, Taiwan

TEL: 886-7-8135500 FAX: 886-7-8225588 / 8159758

Email: info@new-flow.com www.new-flow.com

INSTALLATION

Instructions Manul

Service: Water & liquids

Wetted parts material: Body–Acrylic plastic (POLYPROPYLENE)
O–ring–DPEM

Float guide: 304 stainless steel

Connecting material: POLYPROPYLENE

Temperature & pressure limits: 120 psig(8.4bar)@100°F(38°C)

Temperature limit: 0~45°C

Accuracy: ±3% full scale

Mounting: Vertical

Main Parts List & Installed Method

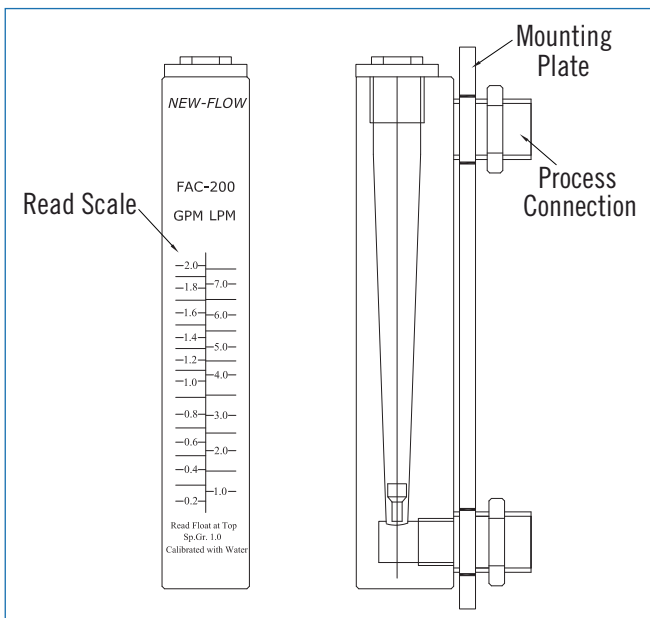

Read Coaction to the Float

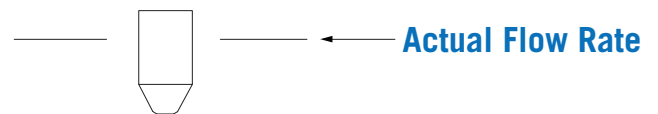

Dimensions

