

NEW-FLOW

**ISO 9001
REGISTERED**

NEW-FLOW

MANUFACTURE OF ACRYLIC PLASTIC FLOW METER
FBC SERIES
AND CONTROL INSTRUMENTS

Instruction Manual

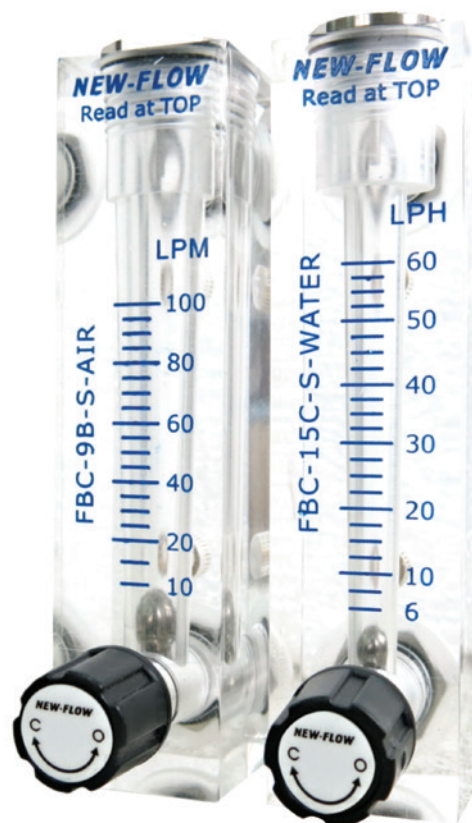

Approvals:



NEW-FLOW TECHNOLOGIES, INC.

No.9 Lane 133, Xing-Hua St., Chien Chen Dist., Kaohsiung 806, Taiwan

TEL: 886-7-8135500 FAX: 886-7-8225588 / 8159758

Email: info@new-flow.com www.new-flow.com

INSTALLATION

Technical Data

Service: Gases & Liquid

Wetted Parts Material: Body– Acrylic Plastic
O-Ring– NBR (standard), Viton on request
Float– SS316, Glass, POM Plastic

Valve Material: SS316

Connection Material: SS316

Connection Size: 1/8" NPT female

Temperature & Pressure Limits: 150 psig (10bar) @100°F(38°C)

Temperature Limit: -24°C~+54°C

Accuracy: 3% full scale

Mounting: Vertical position

Weight: 0.12 kg

Dimensions

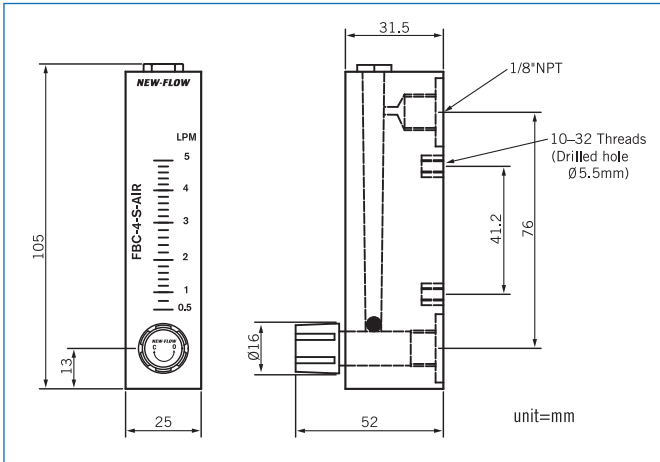

Read Coaction To The Float

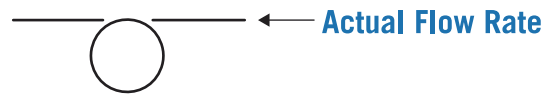

Main Parts List & Installed Method

