

# P-TYPE INSTALLATION

## Applications

### A. Measuring the flow rate for

- Chemical process system
- Water treatment system
- Industrial flow system

### B. Service Condition

- Viscosity  $\leq 100\text{cp}$
- Max working temperature  $100^\circ\text{C}$
- Max working pressure:
  - (1) Glass tube:  $6\text{ kg/cm}^2$ ,  
Instant pressure:  $8\text{ kg/cm}^2$
  - (2) P.C tube:  $10\text{ kg/cm}^2$ ,  
Instant pressure:  $15\text{ kg/cm}^2$

### C. Read Coaction To The Float

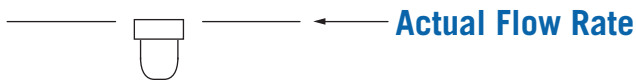

Plastic



Metal

Approvals:



## Dimensions

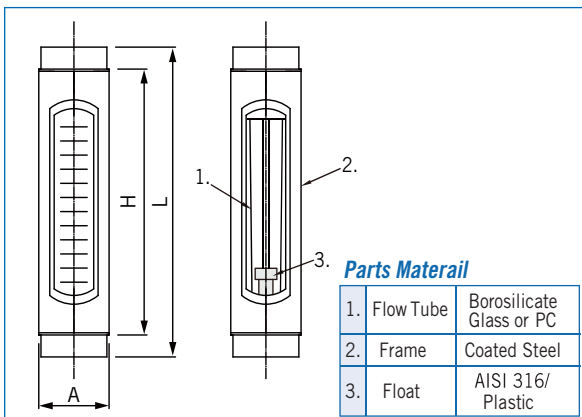

Range Size	H <sub>2</sub> O (MAX) L/min	AIR (MAX) NL/min	DIMENSION			
			L	H	A	PT/NPT
6A	0.03 – 0.3	0.5 – 5.0	200	165	—	1/4"
10A	0.1 – 1.0	2 – 20	200	165	—	3/8"
15A	1 – 10	20 – 200	240	200	—	1/2"
20A	2 – 20	30 – 300	280	240	—	3/4"
25A	5 – 50	100 – 1000	280	240	—	1"
32A	10 – 100	200 – 2000	280	240	—	1 1/4"
40A	20 – 200	300 – 3000	305	240	—	1 1/2"
50A	40 – 400	500 – 5000	315	240	—	2"

## Installation

