

RB-37B

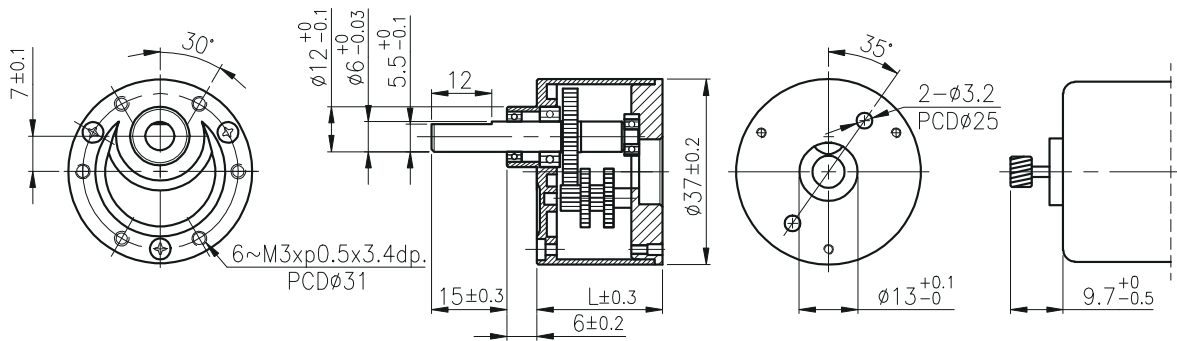

外形尺寸 & 馬達齒鉋合方法 / Appearance Size & Pinion Assembly Dimension



unit:mm

產品規格 / Product Specifications

外殼材質 Housing material	輸出軸承型式 Bearing at output	徑向負荷 Radial load (10mm from flange)	軸向負荷 Shaft axial load	主軸最大承受壓入力 Shaft press fit force, max.	徑向間隙 Radial play of shaft	軸向間隙 Thrust play of shaft	背隙 (無負荷時) Backlash, at no-load
金屬 Metal	滾珠軸承 Ball bearings	≤ 2 kgf	≤ 0.7 kgf	≤ 20 kgf	≤ 0.04 mm	≤ 0.35 mm	≤ 2°

馬達齒輪型式 / Pinion Specifications

模數 Module	齒數 No. of teeth	壓力角 Pressure angle	螺旋角 Helix angle	孔徑 (mm) Hole diameter	減速比 Reduction ratio
0.5	10	20°	18° (左, left)	∅ 1.98, ∅ 2.28, ∅ 2.48, ∅ 2.98, ∅ 3.16	全種通用 Practicable

標準減速比型式 / Gearboxes Specifications

減速比 Reduction ratio	1/6, 1/10	1/18	1/30	1/50, 1/60, 1/70	1/75, 1/90,	1/100	1/120, 1/150, 1/180 1/200, 1/250, 1/300	1/350, 1/400, 1/450 1/500, 1/600, 1/700	1/750, 1/900, 1/1000	1/1500, 1/3000
定格容許扭力 Rated tolerance torque	1 kgf-cm Max.	1 kgf-cm Max.	2 kgf-cm Max.	3 kgf-cm Max.	4 kgf-cm Max.	6 kgf-cm Max.	6 kgf-cm Max.	6 kgf-cm Max.	6 kgf-cm Max.	6 kgf-cm Max.
瞬間容許扭力 Max momentary tolerance torque	3 kgf-cm	3 kgf-cm	6 kgf-cm	9 kgf-cm	12 kgf-cm	18 kgf-cm	18 kgf-cm	18 kgf-cm	18 kgf-cm	18 kgf-cm
效率 Efficiency	81%	73%			66%		59%		53%	48%
長度 Length (L)	19.5	22			24.5		27		29.5	32
重量 Weight (g)	64	70			76		82		88	96

- 使用相對溼度：20%~85%RH
Operating relative humidity
- 使用溫度範圍：-10°C~+60°C
Operating temperature range