

# IG-42CRGM

## 01 & 02 TYPE

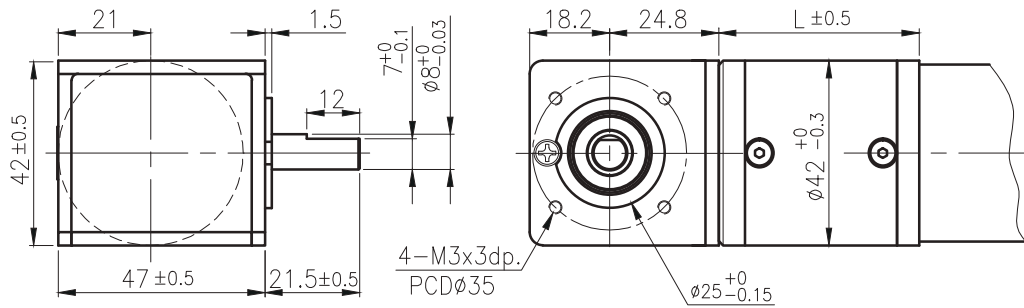

### 外形尺寸/ Appearance Size



unit:mm

### 齒輪馬達轉矩 & 速度/ Geared Motor Torque & Speed

減速比 Reduction ratio		1/4	1/14	1/17	1/24	1/49	1/61	1/84	1/104	1/144	1/212	1/294	1/504	1/624	1/720	1/864	1/1062	1/1470	1/2500	1/3000	1/3600
12V	定格扭力 Rated torque (Kg-cm)	2	6.1	7.6	8	18	18	18	20	20	25	25	30	30	30	30	30	30	30	30	30
	定格轉數 Rated speed (rpm)	1400	405	325	248	120	98	76	63	45	31	24	13.5	10.9	9.5	8	6.5	4.6	2.7	2.3	1.9
24V	定格扭力 Rated torque (Kg-cm)	1.6	5	6.2	8	15	18	18	20	20	25	25	30	30	30	30	30	30	30	30	30
	定格轉數 Rated speed (rpm)	1445	420	340	240	122	102	77.5	63	47	31	23.8	13.5	10.9	9.5	8	6.5	4.6	2.7	2.3	1.9
軸心迴轉方向 Rotation direction		CCW																			
長度 Length (L)		32.5	39.2		45.9		52.6		59.6												

### 馬達單體型式/ Motor Data

定格電壓 Rated volt (V)	定格扭力 Rated torque (g-cm)	定格轉數 Rated speed (rpm)	定格電流 Rated current (mA)	無負荷轉數 No load speed (rpm)	無負荷電流 No load current (mA)	定格出力 Rated output (W)	重量 Weight (g)
12	700	5700	≤ 5500	7000	≤ 900	41.3	360
24	570	5900	≤ 2100	7000	≤ 500	34.7	360

### 馬達單體特性/ Motor Characteristics

