

IG-42CRGM

03 & 04 TYPE

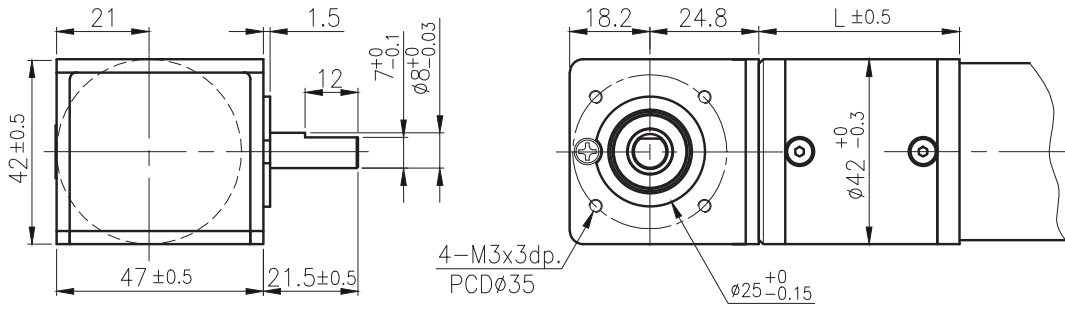

外形尺寸/ Appearance Size



unit:mm

齒輪馬達轉矩 & 速度/ Geared Motor Torque & Speed

| | | 1/4 | 1/14 | 1/17 | 1/24 | 1/49 | 1/61 | 1/84 | 1/104 | 1/144 | 1/212 | 1/294 | 1/504 | 1/624 | 1/720 | 1/864 | 1/1062 | 1/1470 | 1/2500 | 1/3000 | 1/3600 | |
|------------------------------|------------------------------|------|------|------|------|------|------|------|-------|-------|-------|-------|-------|-------|-------|-------|--------|--------|--------|--------|--------|--|
| 12V | 減速比 Reduction ratio | 1/4 | 1/14 | 1/17 | 1/24 | 1/49 | 1/61 | 1/84 | 1/104 | 1/144 | 1/212 | 1/294 | 1/504 | 1/624 | 1/720 | 1/864 | 1/1062 | 1/1470 | 1/2500 | 1/3000 | 1/3600 | |
| | 定格扭力 Rated torque (Kg-cm) | 1.2 | 3.8 | 4.7 | 6.5 | 11.3 | 14 | 18 | 20 | 20 | 25 | 25 | 30 | 30 | 30 | 30 | 30 | 30 | 30 | 30 | 30 | |
| | 定格轉數 Rated speed (rpm) | 930 | 265 | 210 | 150 | 76 | 61 | 45 | 37 | 27 | 18.5 | 14 | 8.3 | 6.9 | 5.9 | 4.9 | 4 | 2.8 | 1.7 | 1.4 | 1.2 | |
| 24V | 定格扭力 Rated torque (Kg-cm) | 1 | 3 | 3.8 | 5.2 | 9.2 | 11.4 | 16 | 20 | 20 | 25 | 25 | 30 | 30 | 30 | 30 | 30 | 30 | 30 | 30 | 30 | |
| | 定格轉數 Rated speed (rpm) | 945 | 270 | 215 | 155 | 76 | 62 | 45 | 36 | 27 | 18.5 | 14 | 8.3 | 6.9 | 5.9 | 4.9 | 4 | 2.8 | 1.7 | 1.4 | 1.2 | |
| 軸心迴轉方向 Rotation direction | | CW | | | | | | | | | | | | | | | | | | | | |
| 長度 Length (L) | | 32.5 | | | 39.2 | | | 45.9 | | | 52.6 | | | 59.6 | | | | | | | | |

馬達單體型式/ Motor Data

| 定格電壓 Rated volt (V) | 定格扭力 Rated torque (g-cm) | 定格轉數 Rated speed (rpm) | 定格電流 Rated current (mA) | 無負荷轉數 No load speed (rpm) | 無負荷電流 No load current (mA) | 定格出力 Rated output (W) | 重量 Weight (g) |
|------------------------|-----------------------------|---------------------------|----------------------------|------------------------------|-------------------------------|--------------------------|------------------|
| 12 | 430 | 3750 | ≤ 2000 | 4500 | ≤ 500 | 16.56 | 310 |
| 24 | 350 | 3800 | ≤ 820 | 4500 | ≤ 220 | 13.65 | 310 |

馬達單體特性/ Motor Characteristics

