

NEW-FLOW

**ISO 9001
REGISTERED**

NEW-FLOW

MAGNETIC FLOAT LEVEL SWITCH
LS SERIES

Instruction Manual

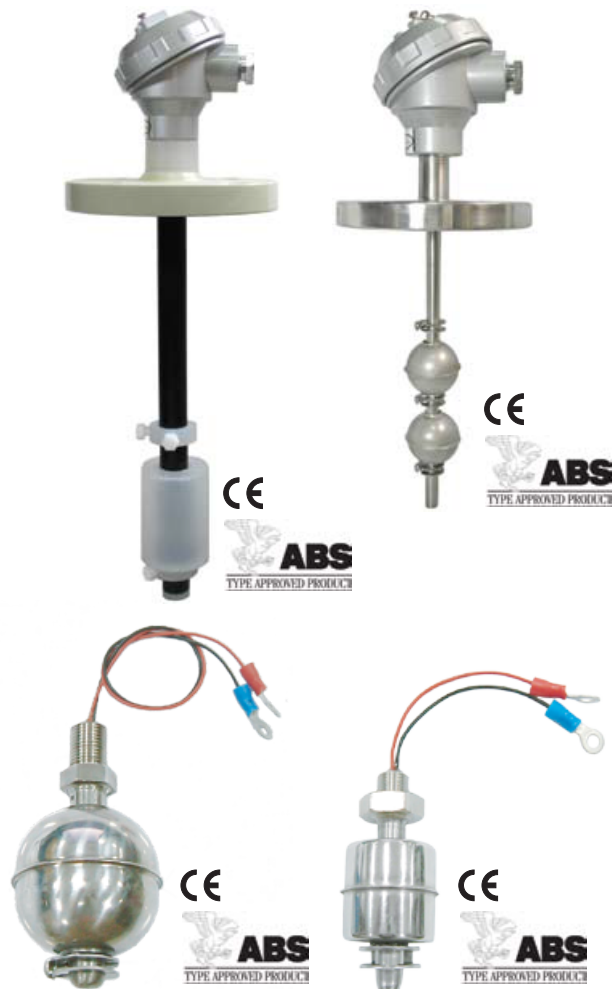

NEW-FLOW TECHNOLOGIES, INC.

No.9 Lane 133, Xing-Hua St., Chien Chen Dist., Kaohsiung 806, Taiwan

TEL: 886-7-8135500 FAX: 886-7-8225588 / 8159758

Email: info@new-flow.com www.new-flow.com

INSTALLATION

Technical Data

Material: Wetted parts are available for SS304, SS316, PVC, PP, PVDF by requested. Multiple level point are available by requested for customer.

Enclosure housing: IP65 and IP67, Explosion proof, Weather proof
Straight style LS series: LS-simple type, WLS-IP65 & weather proof, ELS-explosion proof

Angle style series: LA-simple type, WLA-IP65 & weather proof, ELA-explosion proof

Connection size: Thread Type—1½" to 3", Flange Type—1½" to 4"

Head Type Technical Data



HN TYPE

HN Type

Protection: IP67
Material: Aluminum Alloy
Weight: 264g
Protection tube connection: ½", ¾" (PF, NPT, BSP), M20X1.5
Extension wire connection: ½", ¾" (PF, NPT, BSP), M20X1.5
 Other specifications are available on request.

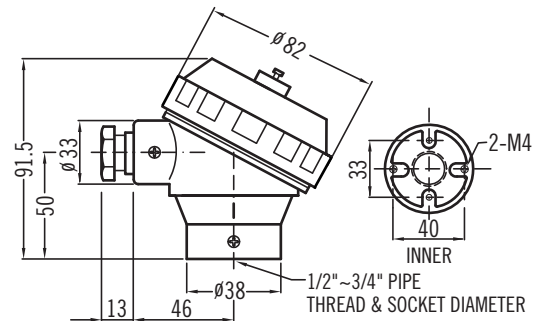

HP TYPE

HP Type

Protection: IP65
Material: Polypropylene
Weight: 112g
Protection tube connection: ½" NPT, ½" BSP
Extension wire connection: ¾" NPT, M20X1.5
 Other specifications are available on request.

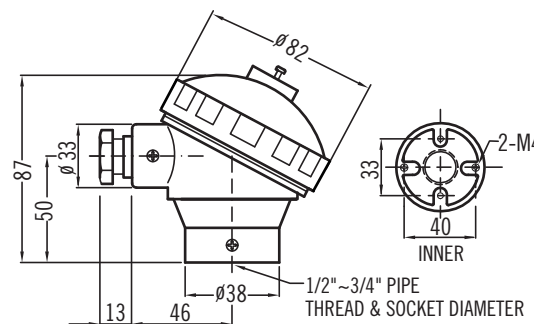

KS TYPE

KS Type

Protection:	FM/CSA Approvals	Class I, DIV I Groups B, C and D Class II, DIV I Groups E, F and G
	CENELEC Approvals	Eexd IIC ATEX II 2G

Material: 316SS
Weight: 900g
 Other specifications are available on request.

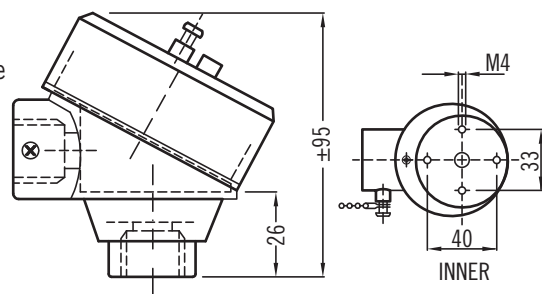

INSTALLATION

Head Type Technical Data



S2 TYPE

S2 Type

Protection: Explosion proof. EExdIICT6 IP65

Material: Aluminum Alloy

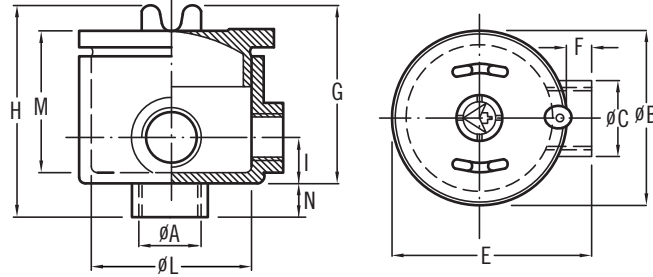

Type	Dimensions										Terminal Block (on request)	Weight Gr.	
	$\varnothing A$	$\varnothing B$	$\varnothing C$	E	F	G	H	I	$\varnothing L$	M			N
S2	$\frac{3}{4}$ "	90	38	100	10	78	92	24	76	69	14	4x4 mm ²	510

Float Specification

A. Metal

<p>$\varnothing 75 \times 75 \text{mm (SUS316)}$</p> <p>Flow Size: $\varnothing 75$ Max. Working Pressure: 30 kg/cm² Working S.G.: ≈ 0.68 The Guide Tube Size: $\varnothing 17.2$ Material: SUS316 Limited Operating Temperature: -20 ~ 140°C</p>	<p>$\varnothing 49 \times 49 \text{mm (SUS316)}$</p> <p>Flow Size: $\varnothing 49$ Max. Working Pressure: 30 kg/cm² Working S.G.: ≈ 0.68 The Guide Tube Size: $\varnothing 12$ Material: SUS316 Limited Operating Temperature: -20 ~ 140°C</p>
<p>$\varnothing 40 \times 38 \text{mm (SUS316)}$</p> <p>Flow Size: $\varnothing 40$ Max. Working Pressure: 30 kg/cm² Working S.G.: ≈ 0.8 The Guide Tube Size: $\varnothing 9.5$ Material: SUS316 Limited Operating Temperature: -20 ~ 140°C</p>	<p>$\varnothing 28 \times 27 \text{mm (SUS316)}$</p> <p>Flow Size: $\varnothing 28$ Max. Working Pressure: 15 kg/cm² Working S.G.: ≈ 0.8 The Guide Tube Size: $\varnothing 8$ Material: SUS316 Limited Operating Temperature: -20 ~ 140°C</p>

ON-OFF Gap

A. Metal

<p>$\varnothing 75 \times 75 \text{mm (SUS316)}$</p>	<p>$\varnothing 49 \times 49 \text{mm (SUS316)}$</p>
<p>$\varnothing 40 \times 38 \text{mm (SUS316)}$</p>	<p>$\varnothing 28 \times 27 \text{mm (SUS316)}$</p>

INSTALLATION

Float Specification

B. Non-Metal

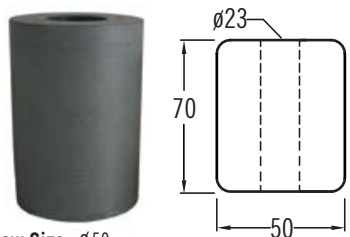
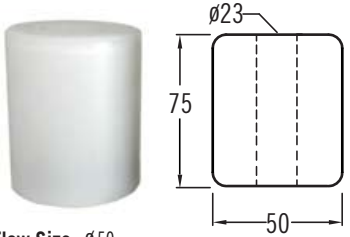
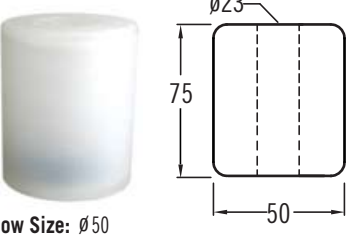
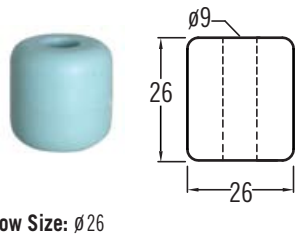





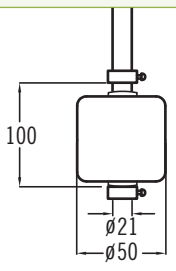
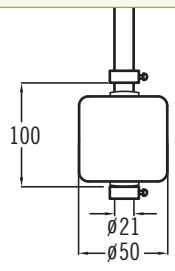
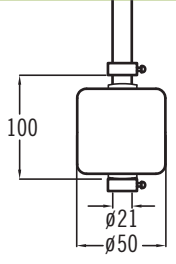
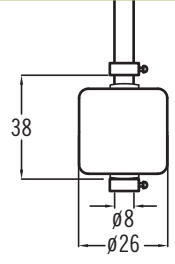

ø50x70mm (P.V.C)	ø50x75mm (PVDF)
 <p>Flow Size: ø50 Max. Working Pressure: 3 kg/cm² Working S.G.: ? 0.7 The Guide Tube Size: ø17.2 Material: P.V.C Limited Operating Temperature: 0~70°C</p>	 <p>Flow Size: ø50 Max. Working Pressure: 5 kg/cm² Working S.G.: ? 0.8 The Guide Tube Size: ø21.5 Material: PVDF Limited Operating Temperature: 0~120°C</p>
ø50x75mm (P.P)	ø26x26mm (P.P)
 <p>Flow Size: ø50 Max. Working Pressure: 3 kg/cm² Working S.G.: ? 0.7 The Guide Tube Size: ø21.5 Material: P.P Limited Operating Temperature: 0~60°C</p>	 <p>Flow Size: ø26 Max. Working Pressure: 3 kg/cm² Working S.G.: ? 0.7 The Guide Tube Size: ø9 Material: P.P Limited Operating Temperature: 0~60°C</p>

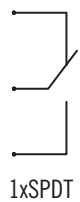
ON-OFF Gap

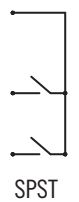
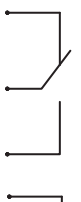
B. Non-Metal

ø50x70mm (P.V.C)	ø50x75mm (SPVDF)
	
ø50x75mm (P.P)	ø26x26mm (P.P)
	

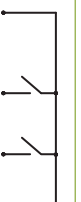
Wiring Code Numbers

One Float		Two Float			Three Float			Four Float		
1	2	3	4	5	6	7	8	9	10	11
Suitable Float Size: ø28, ø40, ø49, ø75							ø40	ø40	ø28	ø49
							ø49	ø49	ø40	ø75
							ø75	ø75	ø49	ø75
										
1xSPST	1xSPDT	2xSPST	SPST (Common Wire Style)	2xSPDT	3xSPST	SPST (Common Wire Style)	3xSPDT	4xSPST	SPST (Common Wire Style)	4xSPDT

INSTALLATION

Switch Function

Total Inserting Length

L= _____ mm

Setting Point & Switch Acting Functions

Please check to the requested length and float rised \uparrow ON or fall down \downarrow ON

l_1 = _____ mm ON l_2 = _____ mm ON

l_3 = _____ mm ON l_4 = _____ mm ON

Switch Table

Contact Form	A (SPST)	C (SPDT)
Switching Capacity Max.	40 W/VA	60 W/VA
Switching Voltage Max.	230V AC/DC	230V AC/DC
Switching Current Max.	2A	1A
Carrying Current Max.	3A	2A
Working Temperature	-40°C~+130°C	-40°C~+130°C

*Special rate available on request.

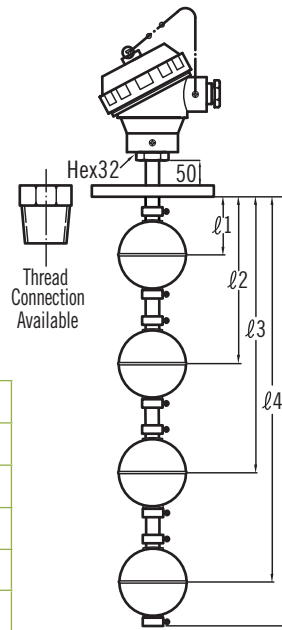

Install Method

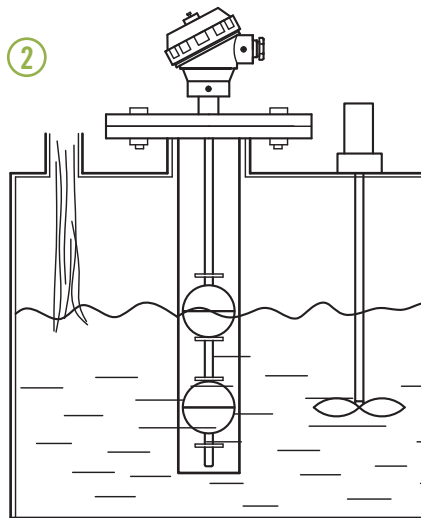
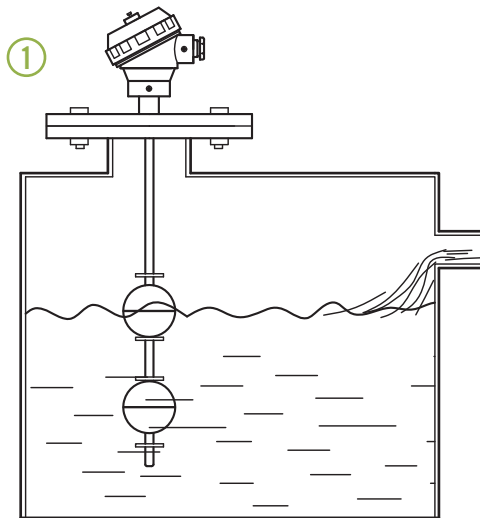

1. To avoid vibrating float to trigger the switch near the water inlet causing by the fluctuation of water level, therefore please install the level switch as far away from the water inlet as possible.

2. Level switch installed in a mixing tank or a water tank which the water level fluctuate greatly, an anti-wave pipe shall be installed to prevent faulty action of the switch due to water level fluctuation.

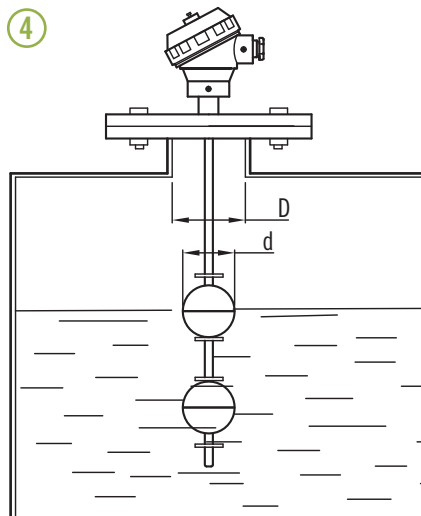
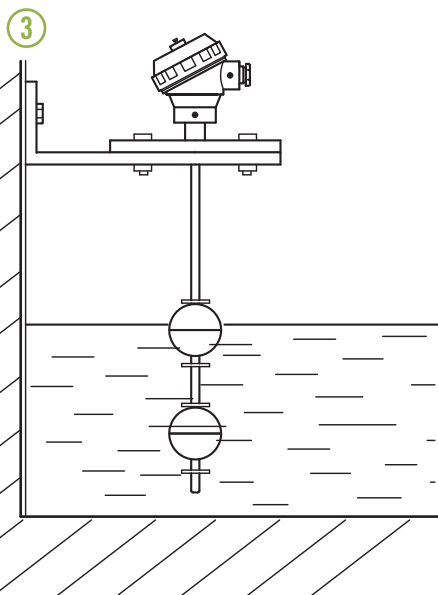

3. When the level switch installs in the open style tank, please note that it is sure to install the L support fixed on the level switch body.

4. Please note that the inside dimensions (D) of nozzle shall be bigger than the diameter of float (d).