

**NEW-FLOW**

**ISO 9001  
REGISTERED**

# ***NEW-FLOW***

MANUFACTURE OF TUBULAR TYPE LEVEL GAUGE

NL/SL Series

## ***Instruction Manual***



***NLT-1***



***NLF-1***



***SLT-1***



***SLF-1***



***SCALE***

***NEW-FLOW TECHNOLOGIES, INC.***

No.9 Lane 133, Xing-Hua St., Chien Chen Dist., Kaohsiung 806, Taiwan

TEL: 886-7-8135500 FAX: 886-7-8225588 / 8159758

Email: [info@new-flow.com](mailto:info@new-flow.com) [www.new-flow.com](http://www.new-flow.com)

# INSTALLATION

## Technical Data

**Suitable Fluid:** Water, Oil, other chemical liquid  
**Gauge Valve Material:** SS304, SS316, others available  
**Gauge Tube Material:** Glass, P.V.C  
**Seal Material:** Viton, Teflon available  
**Gauge Valve Function:** With or Without ball check  
**Max. Working Temperature:** 100°C  
**Max. Working Pressure:** 4~7 kg/cm<sup>2</sup>  
**Process Connection:** ½"~1½" Thread and Flange on request.  
**Flange Rating:** JIS, ANSI, DIN available  
**Drain Valve Connection:** standard ½" NPT(F); option available

## NL Series

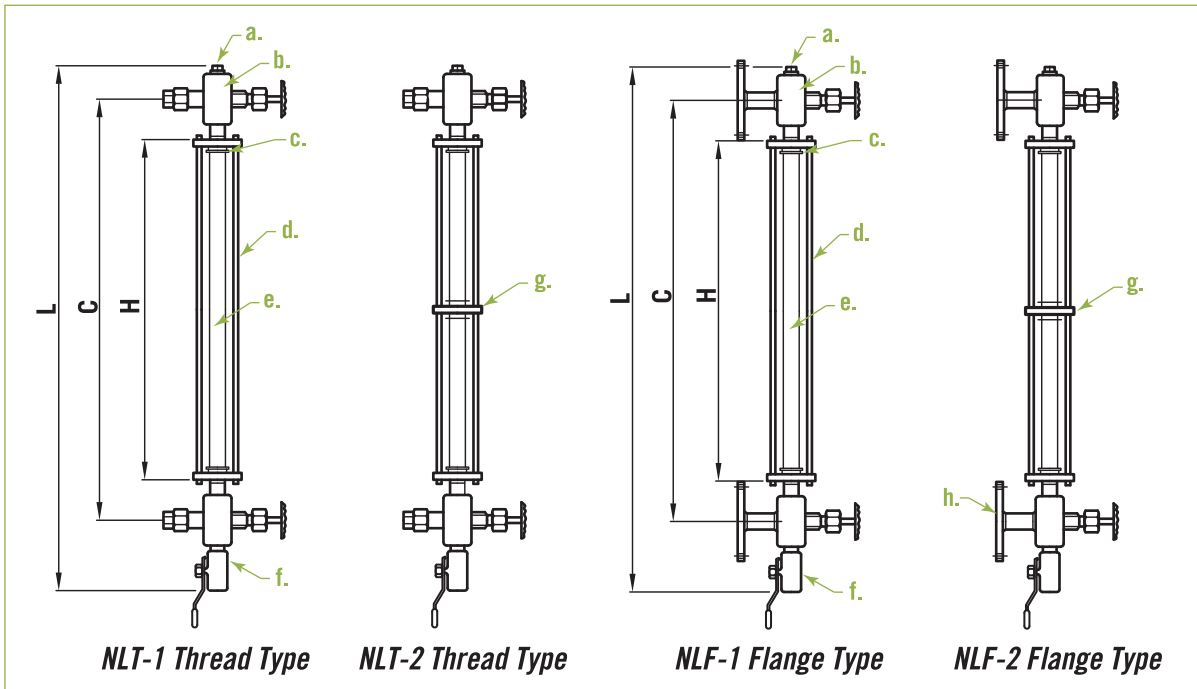

## Dimensions for NL Series

mm Item	L	C	H	Section
1	400	300	200	1
2	600	500	400	1
3	800	700	900	1
4	1200	1100	1000	1
5	1300	1200	1100	1
6	1600	1500	1400	2
7	1900	1800	1700	2
8	2100	2000	1900	2

### NOTE.

The "C" dimension can be made by requirement of customer. Option available.

## Parts List for NL Series

Item	Parts Name
a.	Plug of Vent
b.	Gauge Valve
c.	Gasket & Tightened ring
d.	Support Rod
e.	Indicating Tube
f.	Drain Valve
g.	Support Ring (only for "C" length > 2meters)
h.	Flange

# INSTALLATION

## SL Series

## Dimensions for SL Series

Item	mm	L	C	H	Section
1		400	300	200	1
2		600	500	400	1
3		800	700	900	1
4		1100	900	1000	1
5		1300	1200	1100	1
6		1600	1500	1400	2
7		1900	1800	1700	2
8		2100	2000	1900	2

**NOTE.** The "C" dimension can be made by requirement of customer. Option available.

## Parts List for SL Series

Item	Parts Name
a.	Plug of Vent
b.	Gauge Valve
c.	Gasket & Tighted ring
d.	Support Rod
e.	Indicating Tube
f.	Drain Valve
g.	Flange

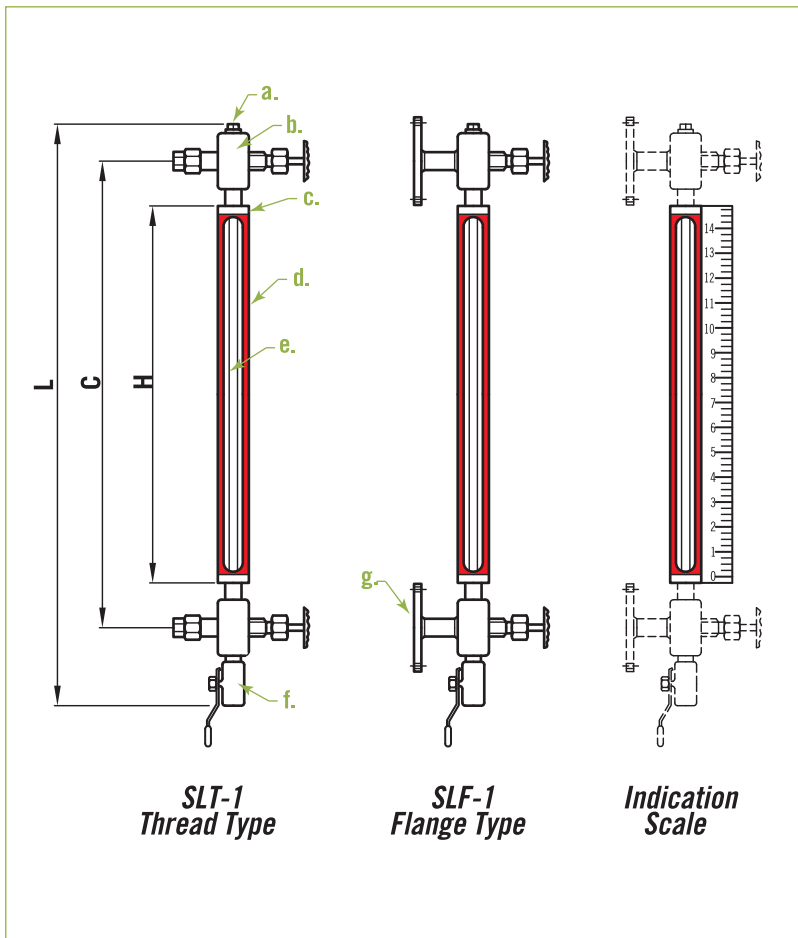

## Notice of Installation

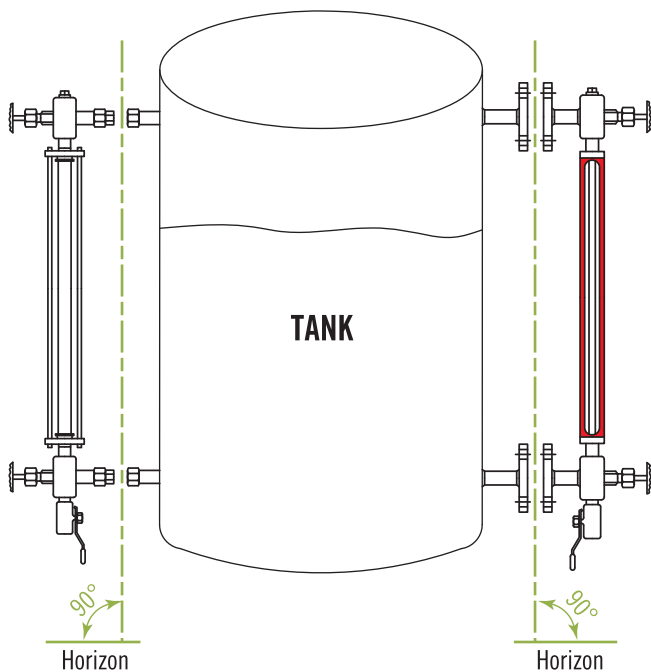

### NOTICE:

1. Please make sure the angular position have to be 90° between the process flange face and horizon. And the position of two process flange face should be in a straight line.
2. Do Not run up on the level gauge with a hammer or any hard tools.