

DUPLEX STRAINER

SH SERIES

- Material: Cast Iron, SS316, SS304 available
- Carbon Steel is unavailable

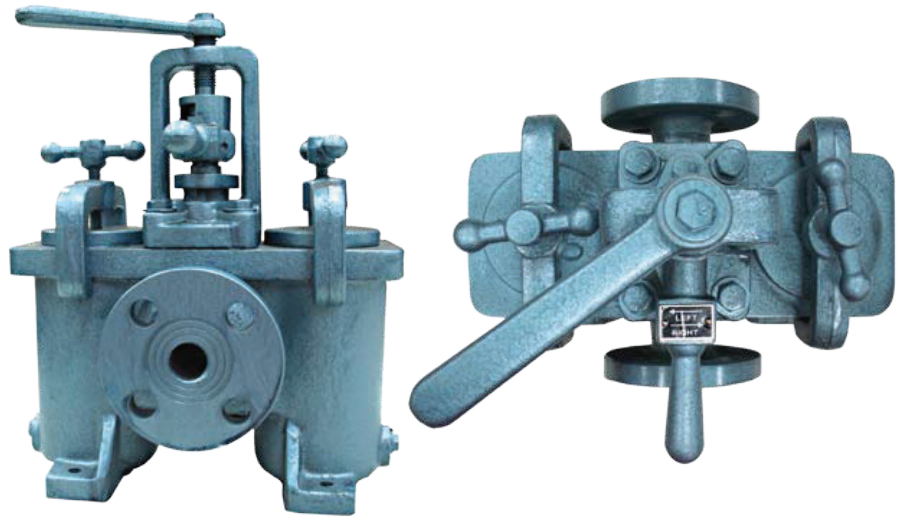

Dimensions

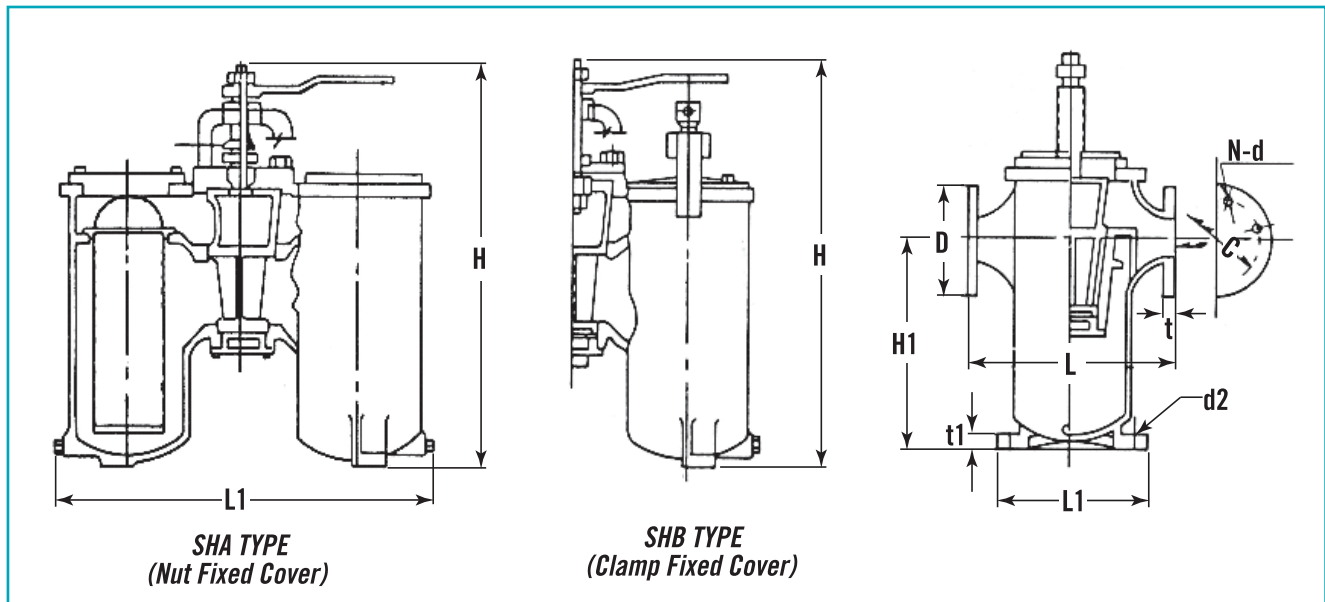

Dimensions Data

Size	L	L1	H	H1
20A	220	310	355	120
25A	220	310	355	120
40A	250	370	465	150
50A	280	440	530	255
65A	280	450	530	255
80A	320	500	620	255
100A	410	580	880	370

unit=mm

Ordering Information

Code	Model
SHA	Duplex strainer- Nut fixed cover type
SHB	Duplex strainer- Clamp fixed cover type
Code	Connection Size
	(1) 20A (2) 25A (3) 40A (4) 50A (5) 65A (6) 80A (7) 100A
Code	Connection Type
	(F) Flange (O) option
Code	Flange Rating
	(A) JIS 10K (only Cast Iron) (B) JIS 20K (C) ANSI 150# (only Cast Iron) (D) ANSI 300# (O) option
Code	Body material
	(1) Cast Iron (2) Steel (3) SS304 (4) SS316 (5) option
Code	Screen Material
	(1) SS304 (2) SS316
Code	Meshes of Screen
	(A) 20 (B) 40 (C) 60 (D) 80 (E) 100 (F) 120 (G) 150 (H) 200
Complete Ordering Code	