

FIELD MOUNTED TEMPERATURE TRANSMITTER WITH DISPLAY T-1000

Explosion Proof
CLASS I, GROUPS A, B, C & D,
CLASS II, GROUPS E, F & G, NEMA 4X

Technical Data

- Enclosure Housing:** Aluminum or SS316
- Input:** Programmable for thermocouple type K, J, R, S, T, N, E, B and RTD PT100Ω from a PC
- Working Span Range:** Programmable from a PC
- LCD Display:** 5 digital (-9999~69999)
- Output:** Linearized 4 to 20mA
- Accuracy:** PT100Ω and 0 to 50mV ±0.15% full scale
 Thermocouple ±0.25% full scale
- Ambient Temperature:** -20 to +85°C
- Power Supply:** 12 to 35 VDC
- Sensor Failure Protection:** Programmable burnout upscale or downscale
- Connection for Sensor:** ½", ¾" available
- Conduit Connection:** ¾"NPT Female; option available
- Mounting Bracket:** 2" available
- Unit:** °C and °F available
- HART® Communication:** available
- Two Wire Transmitter with HART® Protocol:** 
 - Galvanic Isolation
 - Suitable for application in SIL 2 installations



Approvals:



Dimensions-mm

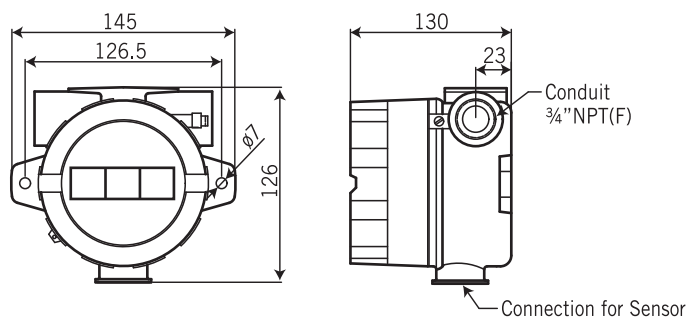

Wire Drawing

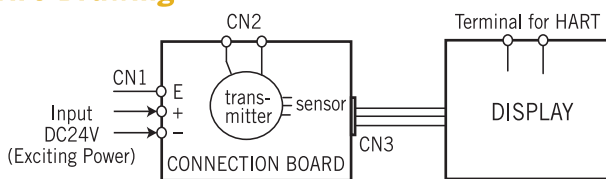

Range Table

Sensor Type	Range	Minimum Measurement Span
Thermocouple K	-50~1370°C	50°C
Thermocouple J	-50~1000°C	50°C
Thermocouple R	-50~1750°C	100°C
Thermocouple S	-50~1750°C	100°C
Thermocouple T	-270~400°C	50°C
Thermocouple N	-50~1300°C	50°C
Thermocouple E	-50~960°C	50°C
Thermocouple B	0~1750°C	100°C
PT100	-200~600°C	20°C
Voltage	-10~+10 Vdc	5mV

Ordering Information

T1000	Code	Sensor Type			
		(1) K (2) J (3) R (4) S (5) T (6) N (7) E (8) B (9) PT100 (10) Voltage			
	Code	Measuring Range	Please fill in the requested measurement range.		
	Code	Output			
	A	4~20mA	H	4~20mA + HART	
	Code	Connection for Sensor	(A) ½"NPT (B) ¾"NPT (O) option		
	Code	Blue Back-Lighted	D	with	N without
	Code	Mounting Bracket	D	with	N without
	Code	Sensor Details	N	No need sensor	
	Y	Please fill in the required Sensor Connection/Diameter/Insertion Length...directly.			
T1000					Complete Ordering Code