

SCREW JACK REDUCER SERIES

螺旋升降器減速機系列

MODEL : VJ

Note:

1. 請參考螺桿桿端尺寸表。
Please refer to dimension of screw end.
2. 行程 Route =H-H1-B

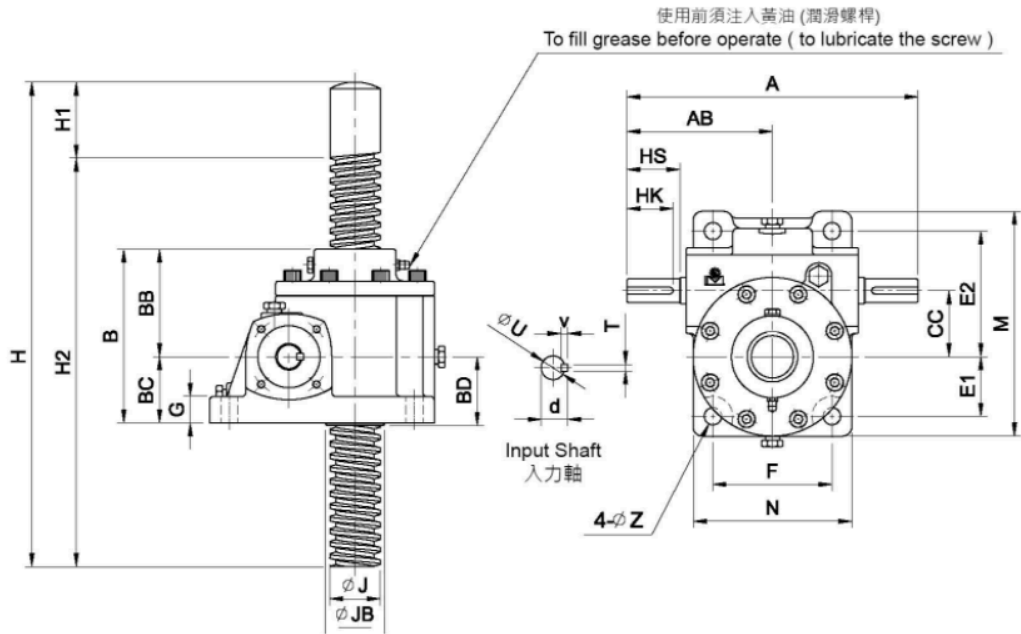

unit: mm

型號 Model	減速比 Ratio	馬力 HP	A	AB	B	BB	BC	BD	CC	腳座 Foot Stock						入力軸 Input Shaft				φJ 螺桿 Screw	JB	螺距 Pitch	H1 Note 1	重量 Weight (kg)	油量 Oil (C.C.)	
										E1	E2	F	M	N	G	Z	HS	U	d							TxVxHK
35	5	1/4	170	85	110	70	40	42	35	38	73	66	135	90	16	11	30	15	17	5x5x25	1"	30	P=5	50	4.1	205
	10									42	83	80	155	110	18	11	40	18	20	5x5x35	1 1/4"	40	P=6	60	7.5	350
	20									45	95	90	170	120	20	13	40	18	20	5x5x35	1 1/2"	45	P=6	70	9	580
40	6	1/4	220	110	130	80	50	52	40	42	83	80	155	110	18	11	40	18	20	5x5x35	1 1/4"	40	P=6	60	7.5	350
	12									45	95	90	170	120	20	13	40	18	20	5x5x35	1 1/2"	45	P=6	70	9	580
	24									45	95	90	170	120	20	13	40	18	20	5x5x35	1 1/2"	45	P=6	70	9	580
50	6	1/2	220	110	130	80	50	52	50	45	95	90	170	120	20	13	40	18	20	5x5x35	1 1/2"	45	P=6	70	9	580
	12									45	95	90	170	120	20	13	40	18	20	5x5x35	1 1/2"	45	P=6	70	9	580
	24									45	95	90	170	120	20	13	40	18	20	5x5x35	1 1/2"	45	P=6	70	9	580
60	8	1	278	139	160	100	60	62	60	70	120	110	230	148	22	17	45	25	28	7x7x40	2"	60	P=8	70	16	640
	16									70	120	110	230	148	22	17	45	25	28	7x7x40	2"	60	P=8	70	16	640
	32									70	120	110	230	148	22	17	45	25	28	7x7x40	2"	60	P=8	70	16	640
70	10	1	318	159	180	110	70	72	70	75	135	140	250	178	25	17	50	28	31	7x7x45	2 1/2"	75	P=10	80	26	980
	20									75	135	140	250	178	25	17	50	28	31	7x7x45	2 1/2"	75	P=10	80	26	980
	40									75	135	140	250	178	25	17	50	28	31	7x7x45	2 1/2"	75	P=10	80	26	980
80	12	2	360	180	210	130	80	82.5	80	90	155	160	295	210	28	21	50	28	31	7x7x45	75mm	90	P=12	80	45	1,200
	18									90	155	160	295	210	28	21	50	28	31	7x7x45	75mm	90	P=12	80	45	1,200
	36									90	155	160	295	210	28	21	50	28	31	7x7x45	75mm	90	P=12	80	45	1,200