

# INDEX ZIPPY SWITCHES DESIGN

## **WATER PROOF** SWITCHES VW1 SERIES



080

## **WATER PROOF** SWITCHES VW1 (IP67) SERIES



084

## **WATER PROOF** SWITCHES MP SERIES



086

## **MICRO** SWITCHES DS SERIES



87

## **MICRO** SWITCHES DS1 SERIES



89

## **MICRO** SWITCHES DA SERIES



91

## **MICRO** SWITCHES DF-M SERIES



93

## **MICRO** SWITCHES DF SERIES



97

## **MICRO** SWITCHES DF3 SERIES



101

## **MICRO** SWITCHES DM SERIES



105

## **MICRO** SWITCHES DW51(IP50) SERIES



109

## **MICRO** SWITCHES SM SERIES



113

## MICRO SWITCHES SM1 SERIES



117

## MICRO SWITCHES SM1(N/G) SERIES



122

## MICRO SWITCHES SW2 SERIES



127

## MICRO SWITCHES V3 SERIES Full-Disconnection-Gap > 3mm



131

## MICRO SWITCHES V3 SERIES Micro-Disconnection-Gap < 3mm



135

## MICRO SWITCHES V3 SERIES Full-Disconnection-Gap > 3mm



139

## MICRO SWITCHES VA1 SERIES



143

## MICRO SWITCHES VA2 SERIES



147

## MICRO SWITCHES VK SERIES



152

## MICRO SWITCHES VM SERIES



156

## MICRO SWITCHES VMN SERIES



160

## ROTARY SWITCHES AN SERIES



164

# MICRO SWITCHES



## DIMENSIONS

Unless otherwise specified, a tolerance of  $\pm 0.4\text{mm}$  applies to all dimensions.

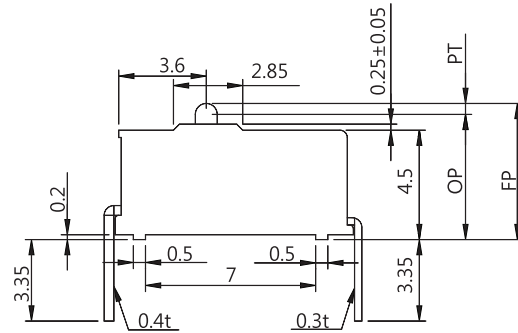
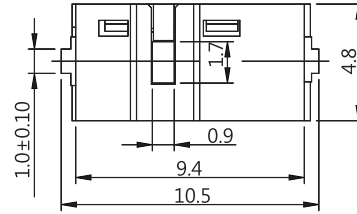

## DS SERIES

### SPECIFICATIONS

#### Contact Resistance(initial)

Max. 800 m $\Omega$

Measured by ohm meter - open voltage < 1VDC, driver current -100 mA

#### Insulation Resistance(at 250 VDC / minute)

Min. 100 M $\Omega$

#### Dielectric Strength

Min. 250VAC(50-60HZ)/minute between Live-parts and dead metal parts

#### Operating Temperature Range

-40°C to 85°C (with no icing)

#### Vibration

10~55Hz, displacement 0.75 mm (p-p)

#### Electrical Service Life

Min.1,000,000 operations

#### Electrical Operating Frequency

120 operations per minute

#### Mechanical Service Life

Min. 3,000,000 operations

#### Mechanical Operating Frequency

120 operations per minute

#### Operating application of the switch

Set the switch pushing distance from 60% to 90% of the specified OT value

### CONTACT CONFIGURATION

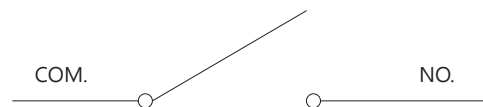

### RATING

0.1A 125VAC, 0.1A 48VDC,  
50mA 12VDC

### APPLICATIONS

Mouse, Joystick

### MOUNTING HOLES

#### P Type Terminal

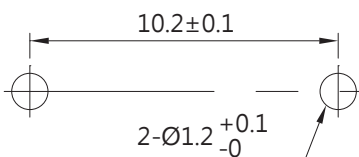

#### D Type Terminal

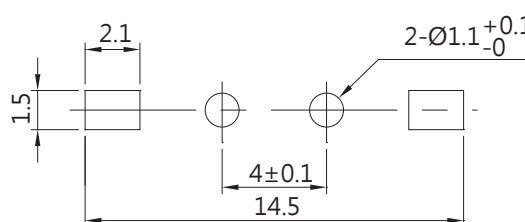

#### R · L Type Terminal

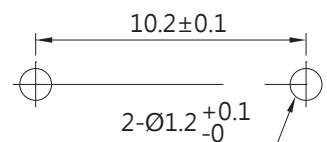

TERMINAL TYPES

P TYPE

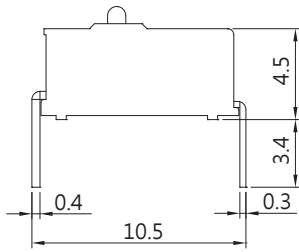

D TYPE

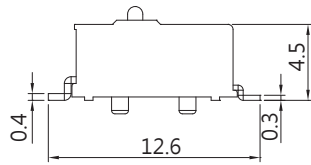

L TYPE

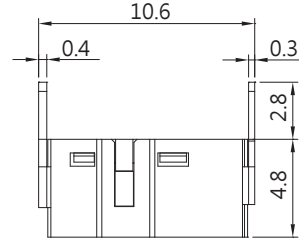

R TYPE

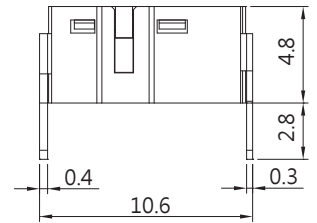

ORDERING INFORMATION

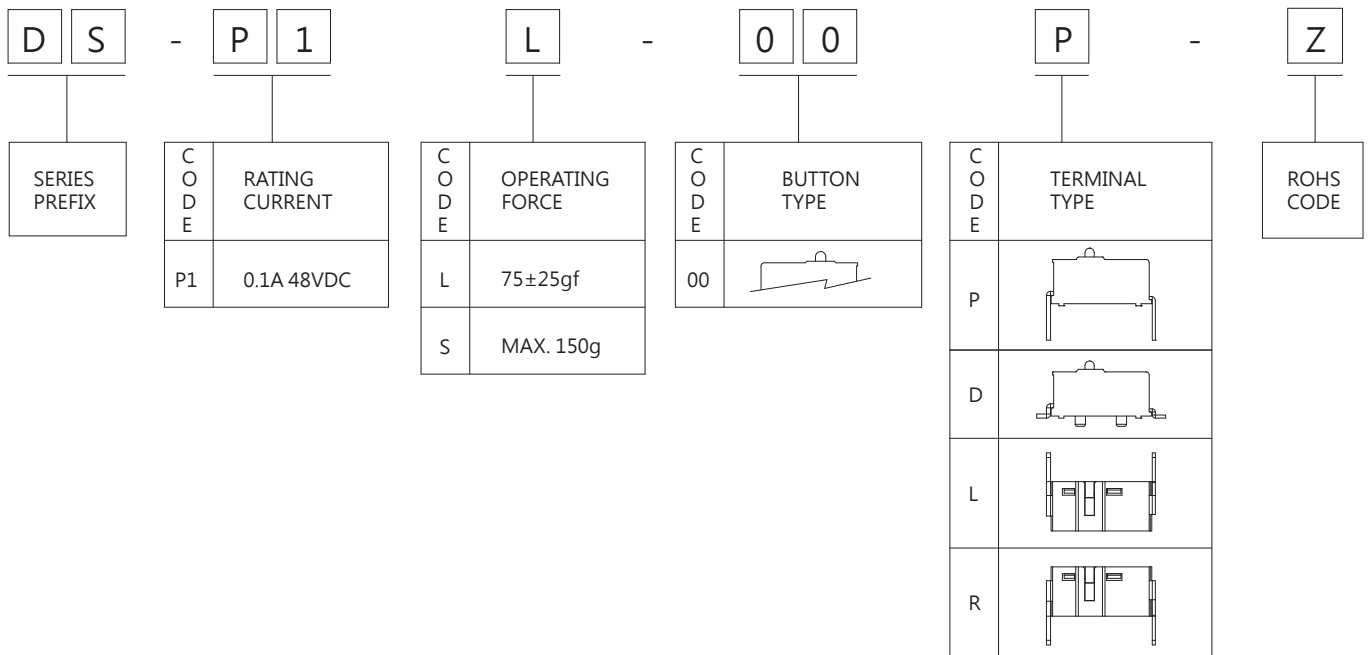

OPERATING CHARACTERISTICS

SWITCH TYPE	PART SUFFIX	OF (gf)	OP (mm)	PT Max. (mm)	OT Min. (mm)	MD Max. (mm)	RF Min. (gf)
DS-P1 □ -00 □ -Z		L	75±25	5.25±0.2	0.95	0.25	0.35
		S	Max.150				
							30

# MICRO SWITCHES



## DS1 SERIES

### SPECIFICATIONS

#### Contact Resistance(initial)

Max. 300 mΩ

Measured by ohm meter - open voltage < 1VDC, driver current -100 mA

#### Insulation Resistance(at 250 VDC / minute)

Min. 100 MΩ

#### Dielectric Strength

Min. 250VAC(50-60HZ)/minute between Live-parts and dead metal parts

#### Operating Temperature Range

-40°C to 85°C (with no icing)

#### Vibration

10~55Hz, displacement 0.75 mm (p-p)

#### Electrical Service Life

Min.3,000,000 operations

#### Electrical Operating Frequency

120 operations per minute

#### Mechanical Service Life

Min. 5,000,000 operations

#### Mechanical Operating Frequency

120 operations per minute

#### Operating application of the switch

Set the switch pushing distance from 60% to 90% of the specified OT value

### RATING

0.1A 12VDC , 0.1A 125VAC

### APPLICATIONS

Mouse, Joystick

### TERMINAL TYPES

#### P TYPE

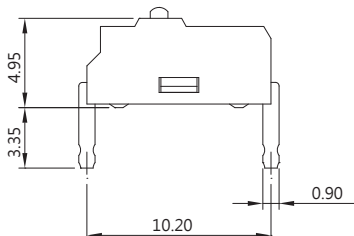

#### C TYPE

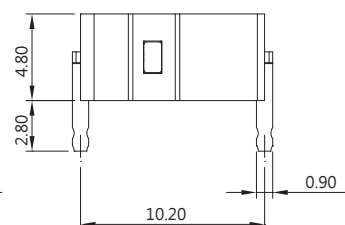

#### D TYPE

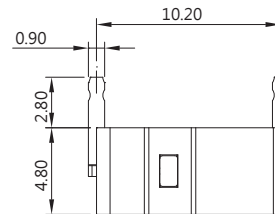

#### T TYPE

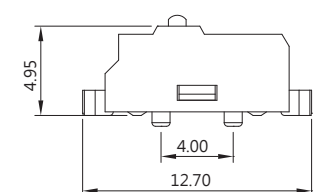

### DIMENSIONS

Unless otherwise specified, a tolerance of ±0.4mm applies to all dimensions.

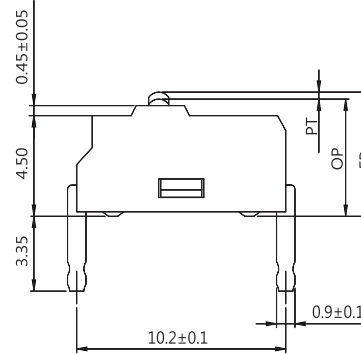
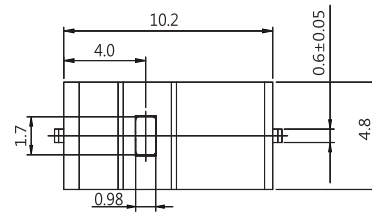

### CONTACT CONFIGURATION

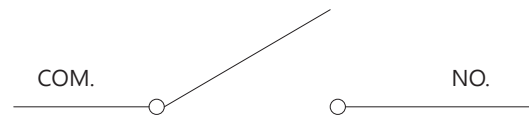

### MOUNTING HOLES

#### P,C,D Type Terminal

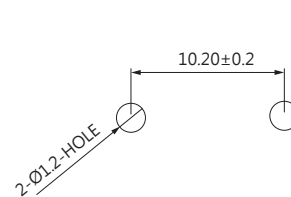

#### T Type Terminal

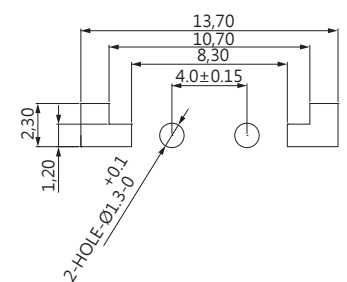

ORDERING INFORMATION

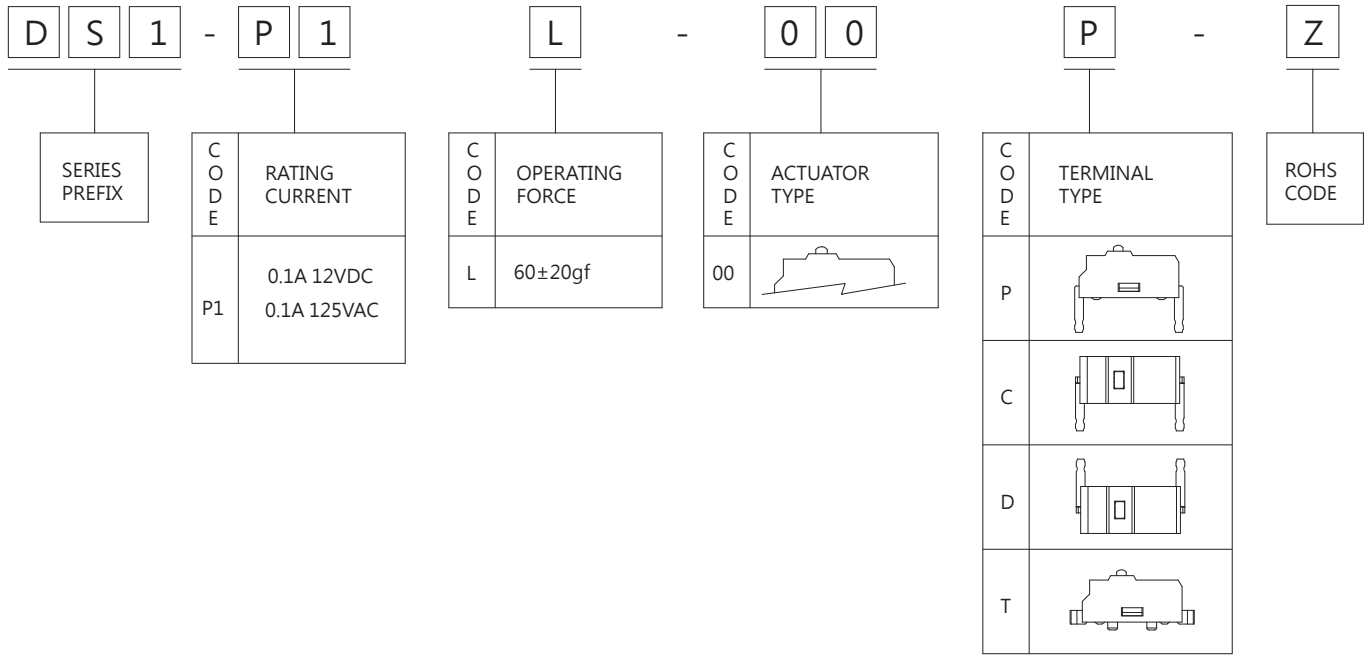

OPERATING CHARACTERISTICS

SWITCH TYPE	PART SUFFIX	OF (gf)	OP (mm)	PT Max. (mm)	OT Min. (mm)	MD Max. (mm)	RF Min. (gf)	
DS1-P1L-00 □ -Z		L	60±20	5.25±0.2	0.62	0.15	0.12	15

# MICRO SWITCHES



## DIMENSIONS

Unless otherwise specified, a tolerance of  $\pm 0.4\text{mm}$  applies to all dimensions.

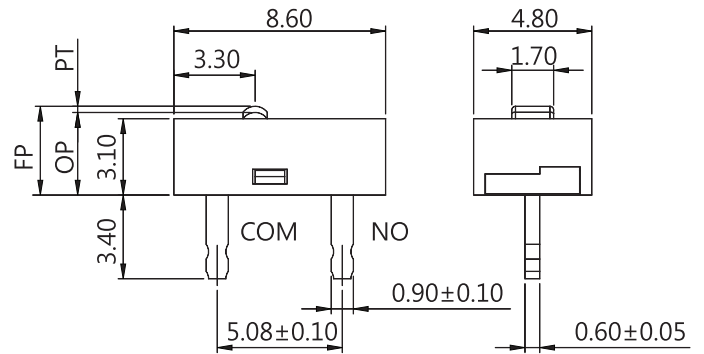

## DA SERIES

### SPECIFICATIONS

#### Contact Resistance(initial)

Max. 100 m $\Omega$

Measured by ohm meter - open voltage < 1VDC, driver current -100 mA

#### Insulation Resistance(at 250 VDC / minute)

Min. 100 M $\Omega$

#### Dielectric Strength

Min. 600VAC(50-60HZ)/minute between Live parts and dead metal parts

#### Operating Temperature Range

-40°C to 85°C (with no icing)

#### Vibration

10~55Hz, displacement 0.75 mm(p-p)

#### Electrical Service Life

Min. 5,000,000 operations

#### Electrical Operating Frequency

120 operations per minute

#### Operating application of the switch

Set the switch pushing distance from 60% to 90% of the specified OT value

### RATING

0.1A 30VDC

### APPLICATIONS

Mouse, Digital Pen

### MOUNTING HOLES FOR PCB TERMINAL

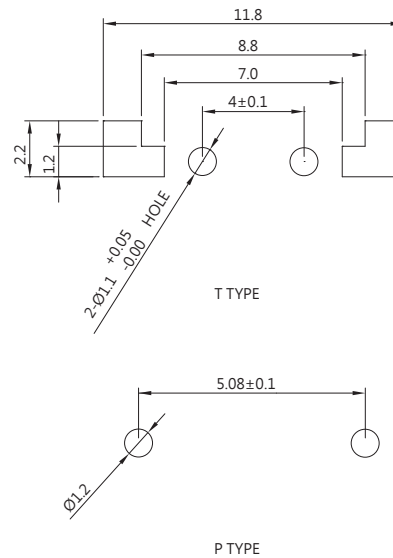

### CONTACT CONFIGURATION

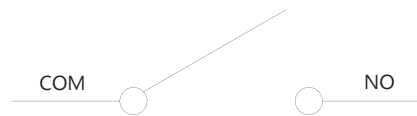

### TERMINAL TYPES

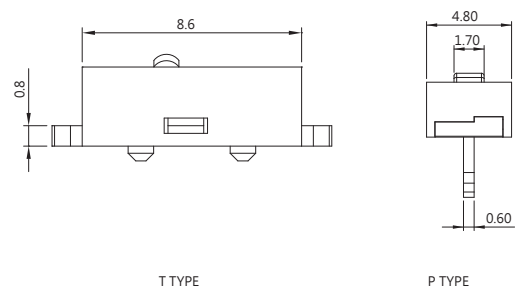

ORDERING INFORMATION

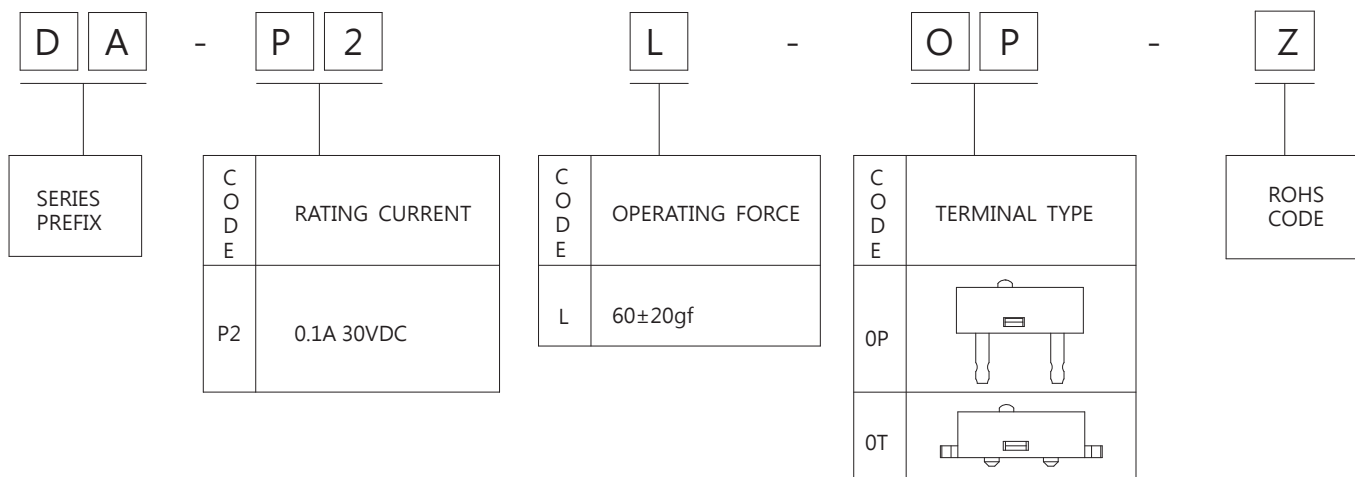

OPERATING CHARACTERISTICS

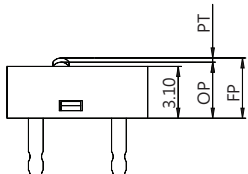
SWITCH TYPE	PART SUFFIX	OF (gf)	OP (mm)	PT Max. (mm)	OT Min. (mm)	FP Max. (mm)	MD Max. (mm)	RF Min. (gf)
DA-P2L-0 □ -Z		60±20	3.35 <sup>+0.2</sup> <sub>-0.15</sub>	0.65	0.1	3.60±0.15	0.12	20



# MICRO SWITCHES



## DIMENSIONS

Unless otherwise specified, a tolerance of  $\pm 0.4\text{mm}$  applies to all dimensions.

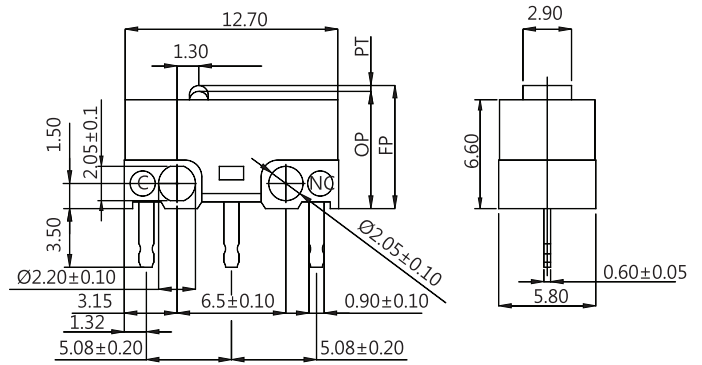

## DF-M SERIES (HIGH OPERATION POINT)

### SPECIFICATIONS

#### Contact Resistance ( initial )

Max. 100m $\Omega$

Measured by ohm meter –Open Voltage < 1VDC, Driver current -100mA

#### Insulation Resistance ( at 500VDC/minute )

Min. 100M $\Omega$

#### Dielectric Strength

Min. 500VAC(50-60HZ)/minute between Live parts

Min. 1500VAC(50-60HZ)/minute between Live parts and dead metal parts

#### Operating Temperature Range

-40°C to 85°C ( with no icing )

#### Vibration

10~55Hz, displacement 0.75 mm (p-p)

#### Electrical Service Life

0.1A - Min. 1,000,000 operations

Other ratings - Min. 10,000 operations

#### Electrical Operating Frequency

10~30 operations per minute

#### Mechanical Service Life

Min. 1,000,000 operations

#### Mechanical Operating Frequency

120 operations per minute

#### Operating application of the switch

Set the switch pushing distance from 60% to 90% of the specified OT value

### CONTACT CONFIGURATION

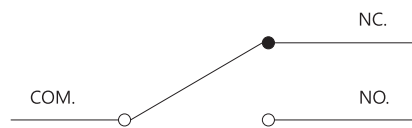

### MOUNTING HOLES FOR PCB TERMINAL

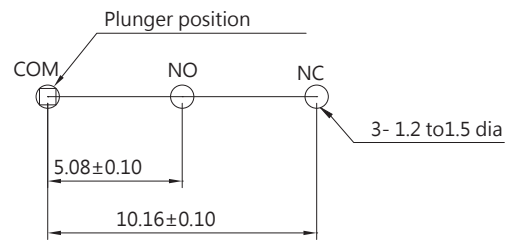

### PRESSING DIRECTION IS SUGGESTED TO BE VERTICAL AND WITH $\pm 4^\circ$

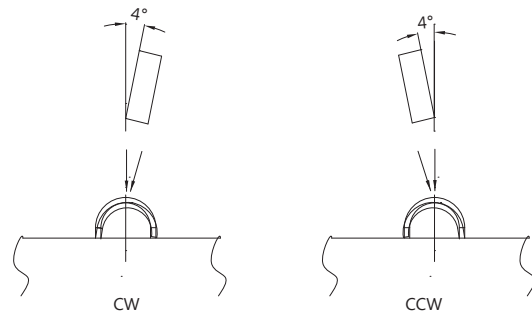

Available for the model that mouse has stoppers added more than Min.0.1mm

### THE SELECTION OF RATING & FORCE

MODEL	Rating	L	S
DF	0.1A	*	*
	1A	*	*
	3A	*	*

NOTE : The Symbol " \* " to represent the result is accepted

### APPLICATIONS

Mouse, Joystick, Small home appliance, Central heating control







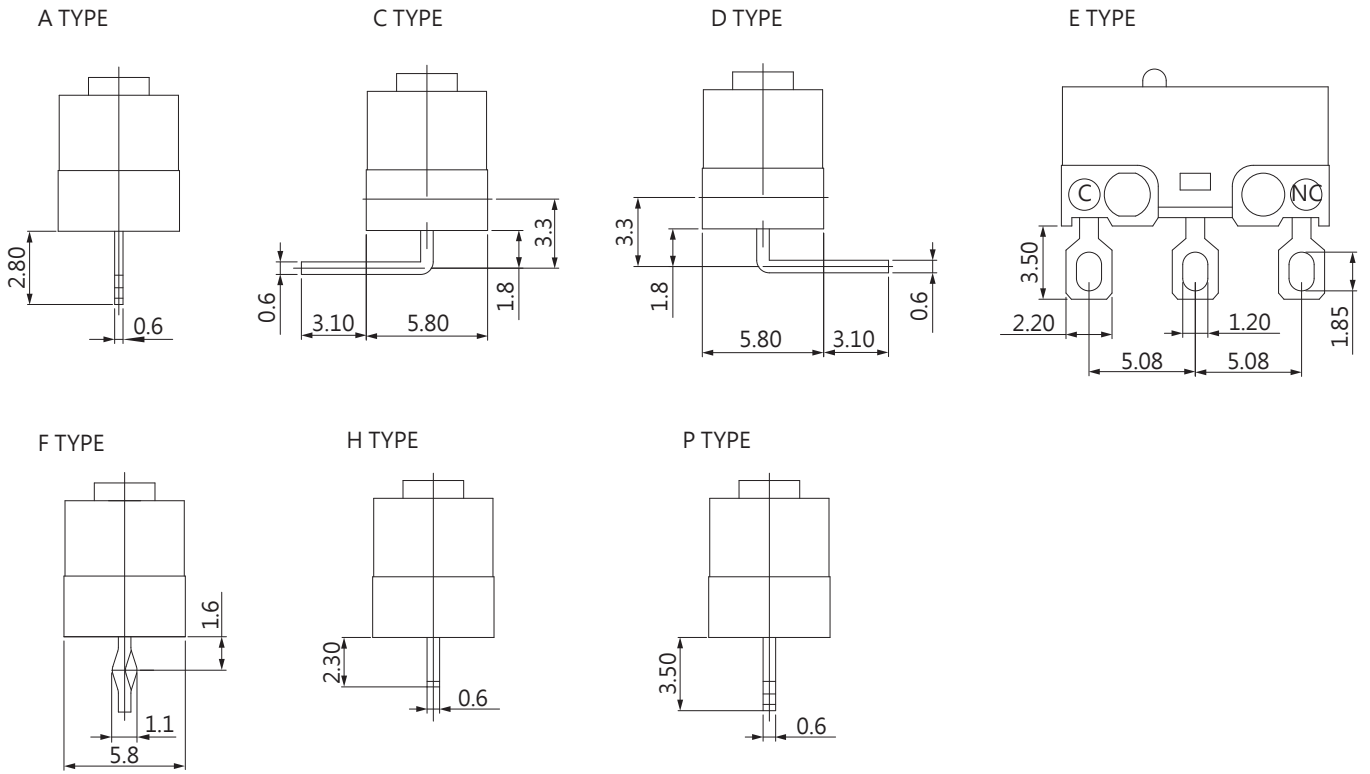









### CERTIFICATE INFORMATION

Model Name	UL, cUL	ENEC
DF-01	1RA 125/250VAC $\mu$ T55 1E4 1RA 24VDC $\mu$ T55 1E4	1A 125/250VAC $\mu$ T55 1E4 1A 24VDC $\mu$ T55 1E4
DF-03	3A 125VAC (Temp:65°C) Min. 6000 operations	3A 125VAC $\mu$ T55 1E4
DF-G3	3A 125VAC(Temp:65°C) Min. 6000 operations	Non
DF-D3	3A 5VDC /12VDC (Temp:65°C) Min. 6000 operations	Non

TERMINAL TYPES



ORDERING INFORMATION

D	F	P	1	L	0	P	M	Z			
SERIES PREFIX											
		C O D E	RATING CURRENT	C O D E	OPERATING FORCE	C O D E	ACTUATOR TYPE	C O D E	TERMINAL TYPE	HIGH OPERATION POINT	ROHS CODE
		P1	0.1A 125VAC	L	LIGHT	0		A			
		01	1A 125/250VAC	S	STANDARD	1		C			
		03	3A 125VAC			2		D			
		G1	0.1A 125VAC CONTACT PLATED GOLD			3		H			
		G3	3A 125VAC CONTACT PLATED GOLD			4		F			
		D3	3A 12VDC			5		P			
						6		E			
						7					
						8					
						9					

OPERATING CHARACTERISTICS

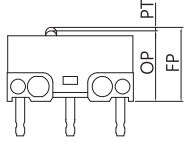
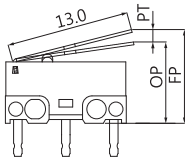
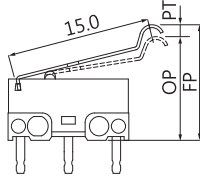
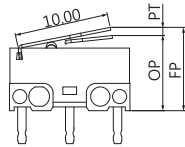
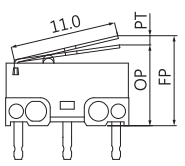
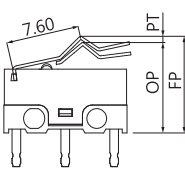
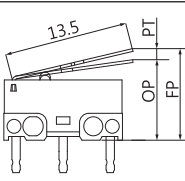
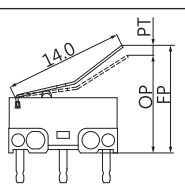
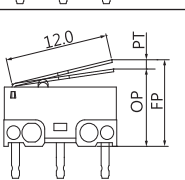
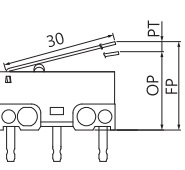
SWITCH TYPE	PART SUFFIX	OF Max. (gf)		OP (mm)	PT Max. (mm)	OT Min. (mm)	MD Max. (mm)	FP Max. (mm)	RF Min. (gf)
		L	S						
DF- □□□ -0 □ -M-Z		L	80	7.0±0.2	0.62	0.2	0.12	7.35	21
		S	150						35
DF- □□□ -1 □ -M-Z		L	30	8.4±0.8	3.0	0.6	0.8	10.6	5
		S	56						8
DF- □□□ -2 □ -M-Z		L	25	10.5±0.8	3.5	0.6	1.0	13.2	5
		S	43						7
DF- □□□ -3 □ -M-Z		L	35	7.9±0.8	2.9	0.3	0.6	10.0	5
		S	57						12
DF- □□□ -4 □ -M-Z		L	39	8.1±0.8	3.0	0.6	0.7	10.3	6
		S	69						10
DF- □□□ -5 □ -M-Z		L	50	9.1±0.8	2.0	0.4	0.3	11.0	5
		S	70						11
DF- □□□ -6 □ -M-Z		L	30	8.5±0.8	3.0	0.6	0.8	10.7	3
		S	50						8
DF- □□□ -7 □ -M-Z		L	27	11.3±1.0	3.5	0.3	0.8	13.85	3
		S	48						8
DF- □□□ -8 □ -M-Z		L	33	8.2±0.8	2.8	0.6	0.7	11.2	5
		S	54						9
DF- □□□ -9 □ -M-Z		L	13	10.79±2.1	7.7	1.0	1.0	15.63	2
		S	21	10.15±2.3					3

## CAUTIONS:

### 注意事項

1. To secure the switch, please use an M2 small screw on a flat surface and tighten with plane washers or spring washers to securely mount the switch, using a maximum torque of 0.1 N•m.  
若使用定位孔型式，請使用M2小型螺絲固定在平面上，並使用平墊圈或者彈性墊圈以便安全的鎖固開關，鎖固扭力請勿超過0.1 N•m.
2. To ensure the best performance of the switch, when handling/installing the switch, please do not apply uneven pressure to the direction indicated by the arrow in (Figure -1). Any uneven pressure or pressure direction other than the operating direction might be harmful or damage the switch performance.  
為確保開關正常運作，安裝及取用開關時，請勿直接施加壓力在(圖-1)中箭所指示的方向。如圖所示，任何不對稱的壓力或作動方向以外的壓力都不適在開關按柄上。

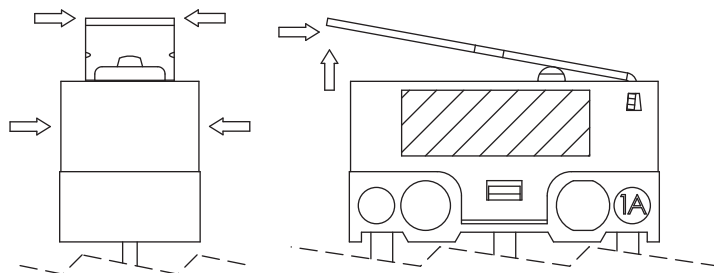

Figure-1

# MICRO SWITCHES



## DIMENSIONS

Unless otherwise specified, a tolerance of  $\pm 0.4\text{mm}$  applies to all dimensions.

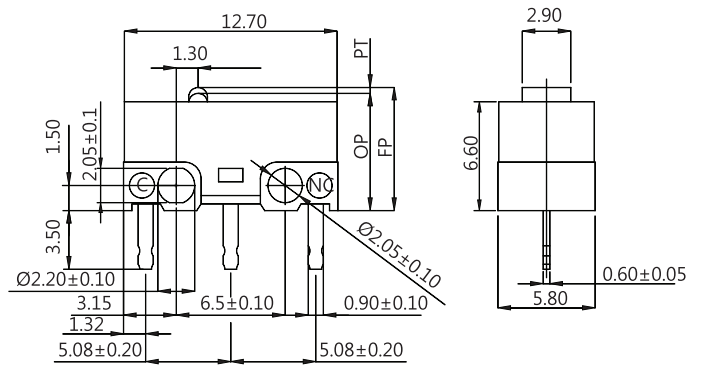

## DF SERIES

### SPECIFICATIONS

#### Contact Resistance ( initial )

Max. 100m $\Omega$

Measured by ohm meter –Open Voltage <1VDC, Driver current -100mA

#### Insulation Resistance ( at 500VDC/minute )

Min. 100M $\Omega$

#### Dielectric Strength

Min. 500VAC(50-60HZ)/minute between Live parts

Min. 1500VAC(50-60HZ)/minute between Live parts and dead metal parts

#### Operating Temperature Range

-40°C to 85°C ( with no icing )

#### Vibration

10~55Hz, displacement 0.75 mm (p-p)

#### Electrical Service Life

0.1A - Min. 1,000,000 operations

Other ratings - Min. 10,000 operations

#### Electrical Operating Frequency

10~30 operations per minute

#### Mechanical Service Life

Min. 1,000,000 operations

#### Mechanical Operating Frequency

120 operations per minute

#### Operating application of the switch

Set the switch pushing distance from 60% to 90% of the specified OT value

### CONTACT CONFIGURATION

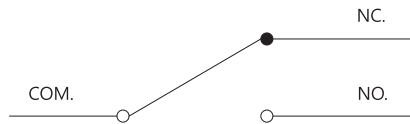

### MOUNTING HOLES FOR PCB TERMINAL

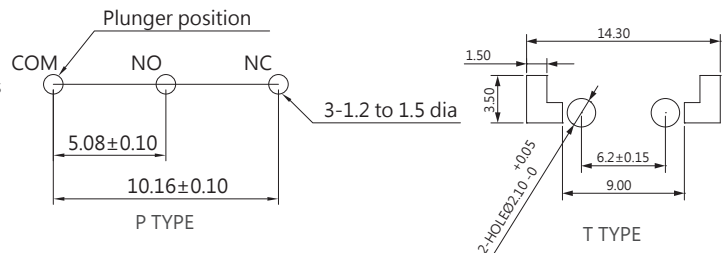

### PRESSING DIRECTION IS SUGGESTED TO BE VERTICAL AND WITH $\pm 4^\circ$

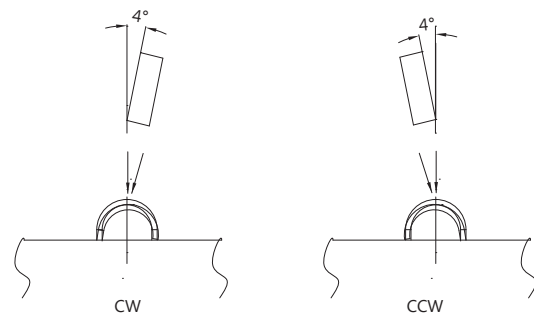

Available for the model that mouse has stoppers added more than Min.0.1mm

### THE SELECTION OF RATING & FORCE

MODEL	Rating	L	S
DF	0.1A	*	*
	1A	*	*
	3A	*	*

NOTE : The Symbol " \* " to represent the result is accepted

### APPLICATIONS

Mouse, Joystick, Small home appliance, Central heating control

### CERTIFICATE INFORMATION

Model Name	UL, cUL	ENEC
DF-01	1RA 125/250VAC $\mu$ T55 1E4 1RA 24VDC $\mu$ T55 1E4	1A 125/250VAC $\mu$ T55 1E4 1A 24VDC $\mu$ T55 1E4
DF-03	3A 125VAC (Temp:65°C) Min. 6000 operations	3A 125VAC $\mu$ T55 1E4 (250VAC option)
DF-G3	3A 125VAC(Temp:65°C) Min. 6000 operations	Non
DF-D3	3A 5VDC /12VDC (Temp:65°C) Min. 6000 operations	Non

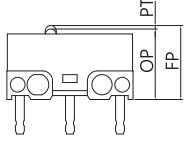
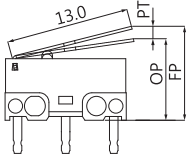
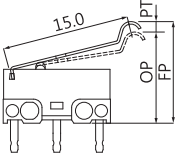
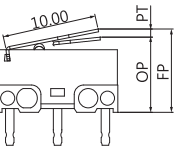
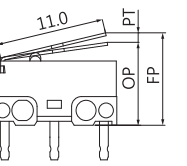
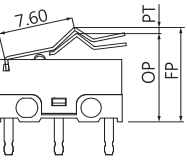
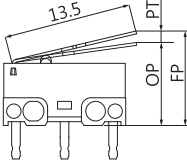
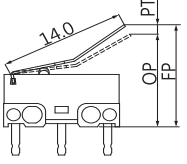
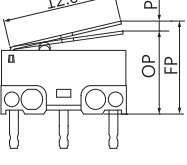
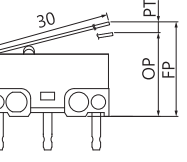

OPERATING CHARACTERISTICS

SWITCH TYPE	PART SUFFIX	OF Max. (gf)		OP (mm)	PT Max. (mm)	OT Min. (mm)	MD Max. (mm)	FP Max. (mm)	RF Min. (gf)
		L	S						
DF- □□□ -0 □ -Z		L	80	7.0±0.2	0.62	0.2	0.12	7.35	21
		S	150						35
DF- □□□ -1 □ -Z		L	30	7.9±0.8	3.4	0.6	0.8	10.1	5
		S	56						8
DF- □□□ -2 □ -Z		L	25	9.8±0.9	3.5	0.7	0.92	14.2	5
		S	43						7
DF- □□□ -3 □ -Z		L	35	7.9±0.7	2.1	0.3	0.29	9.3	5
		S	57						12
DF- □□□ -4 □ -Z		L	39	8.0±0.8	2.5	0.5	0.7	10.8	6
		S	69						10
DF- □□□ -5 □ -Z		L	50	9.0±0.6	1.64	0.49	0.3	10.15	5
		S	70						11
DF- □□□ -6 □ -Z		L	30	8.33±0.9	3.5	0.6	0.8	10.6	3
		S	50						8
DF- □□□ -7 □ -Z		L	27	10.75±0.8	3.5	0.3	0.8	13.5	3
		S	48						8
DF- □□□ -8 □ -Z		L	33	8.17±0.8	2.8	0.6	0.7	11.2	5
		S	54						9
DF- □□□ -9 □ -Z		L	13	9.75±1.9	6.9	0.55	1.9	16.8	2
		S	21	9.5±1.9					3

## CAUTIONS:

### 注意事項

1. To secure the switch, please use an M2 small screw on a flat surface and tighten with plane washers or spring washers to securely mount the switch, using a maximum torque of 0.1 N•m.  
若使用定位孔型式，請使用M2小型螺絲固定在平面上，並使用平墊圈或者彈性墊圈以便安全的鎖固開關，鎖固扭力請勿超過0.1 N•m.
2. To ensure the best performance of the switch, when handling/installing the switch, please do not apply uneven pressure to the direction indicated by the arrow in (Figure -1). Any uneven pressure or pressure direction other than the operating direction might be harmful or damage the switch performance.  
為確保開關正常運作，安裝及取用開關時，請勿直接施加壓力在(圖-1)中箭所指示的方向。如圖所示，任何不對稱的壓力或作動方向以外的壓力都不適在開關按柄上。

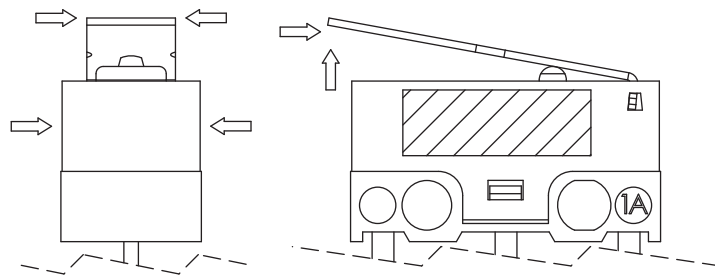

Figure-1



# MICRO SWITCHES



## DIMENSIONS

Unless otherwise specified, a tolerance of  $\pm 0.4\text{mm}$  applies to all dimensions.

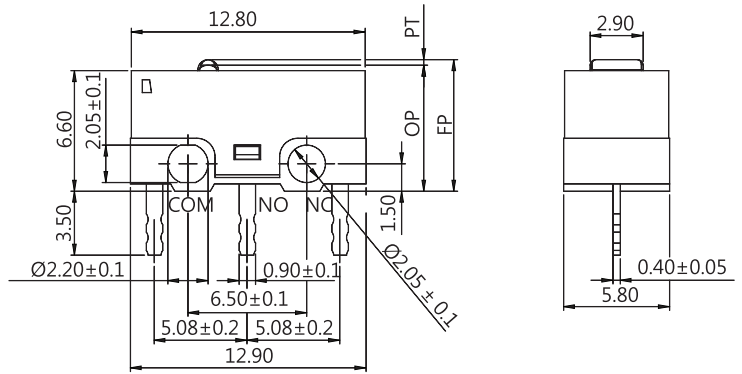

## DF3 SERIES

### SPECIFICATIONS

#### Contact Resistance (initial)

Max. 100m $\Omega$

Measured by ohm meter - open voltage < 1VDC, driver current -100 mA

#### Insulation Resistance (at 500VDC/minute)

Min. 100M $\Omega$

#### Dielectric Strength

Min. 500VAC(50-60HZ)/minute between Live parts.

Min. 1500VAC(50-60HZ)/minute between Live parts and dead metal parts

#### Operating Temperature Range

-40°C to 85°C ( with no icing )

#### Vibration

10~55Hz, displacement 0.75 mm (p-p)

#### Electrical Service Life

Min. 10,000 operations

#### Electrical Operating Frequency

10~30 operations per minute

#### Mechanical Service Life

Min. 5,000,000 operations

#### Mechanical Operating Frequency

120 operations per minute

#### Operating application of the switch

Set the switch pushing distance from 60% to 90% of the specified OT value

### APPLICATIONS

Mouse, Joystick, Small home appliance, Central heating control

### CERTIFICATE INFORMATION

Model Name	UL, cUL	ENEC
DF3-03	3RA 125/250VAC $\mu$ T55 1E4	3A 125/250VAC $\mu$ T55 1E4
DF3-G3	3RA 24VDC $\mu$ T55 1E4	3A 24VDC $\mu$ T55 1E4
DF3-S3	3RA 125VAC $\mu$ T55 5E4 3RA 250VAC $\mu$ T55 3E4 3RA 24VDC $\mu$ T55 1E4	3A 125VAC $\mu$ T55 5E4 3A 250VAC $\mu$ T55 3E4 3A 24VDC $\mu$ T55 1E4
DF3-05	5RA 125/250VAC $\mu$ T85 1E4 3RA 24VDC $\mu$ T85 1E4	5A 125/250VAC $\mu$ T85 1E4 3A 24VDC $\mu$ T85 1E4

### SPECIAL APPLICATIONS FOR GAMING MOUSE

DF3-0.1A, Min. 20,000,000 operations

### CONTACT CONFIGURATION

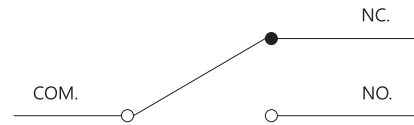

### MOUNTING HOLES FOR PCB TERMINAL

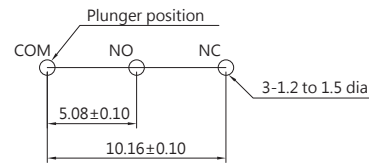

### PRESSING DIRECTION IS SUGGESTED TO BE VERTICAL AND WITH $\pm 4^\circ$

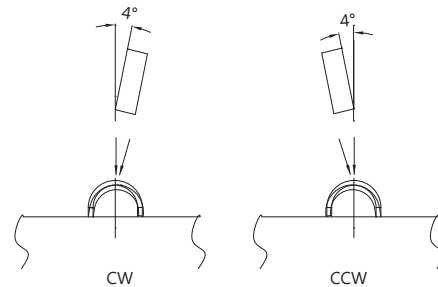

Available for the model that mouse has stoppers added more than Min.0.1mm

### THE SELECTION OF RATING & FORCE

Model	Rating	L	S
DF3-03	3A	*	*
DF3-G3	3A	*	*
DF3-S3	3A	*	*
DF3-05	5A	*	*

NOTE : The Symbol " \* " to represent the result is accepted

TERMINAL TYPES

E type

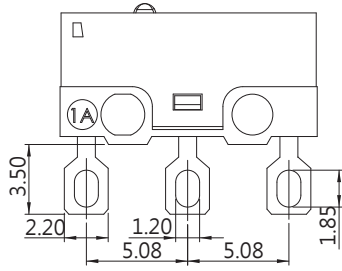

P type

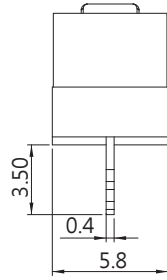

C type

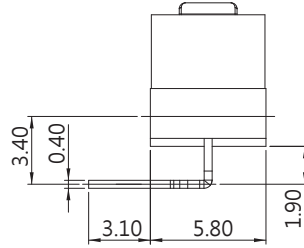

D type

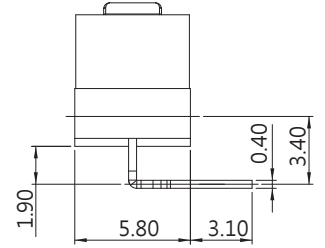

PILLAR TYPES

A0 type

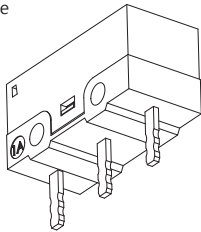

B0 type

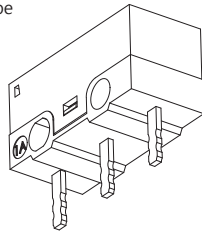

C1 type

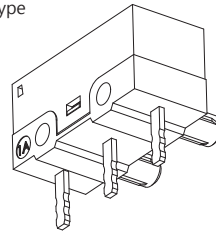

C2 type

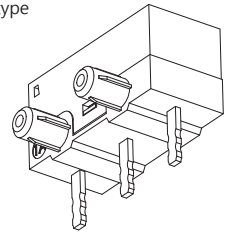

C3 type

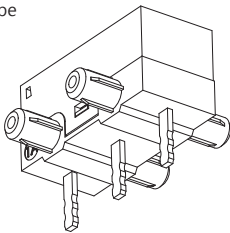

D4 type

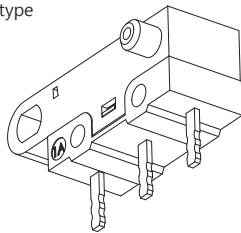

D5 type

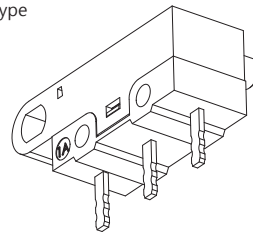

D6 type

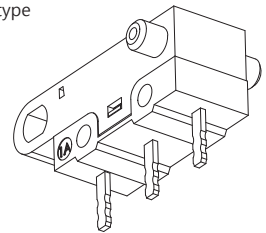

ORDERING INFORMATION

D	F	3	—	0	3	S	0	—	0	1	P	0	C	1	—	0	A	—	Z													
SERIES PREFIX	CODE	RATING CURRENT	CODE	OPERATING FORCE	CODE	STRUCTURE TYPE	CODE	ACTUATOR TYPE	CODE	TERMINAL TYPE	CODE	CIRCUIT ARRANGEMENT	CODE	PILLAR & MOUNTING HOLES TYPE	CODE	PILLAR TYPE	SPECIAL CODE	ROHS CODE														
	G3	3A 125/250VAC	S	STANDARD	0	SINGLE BLADE	00		C		0	S.P.D.T	A		0	WITHOUT PILLAR																
	G5	5A 125/250VAC	L	LIGHT			01		D		1	S.P.S.T NO	B		1																	
	S3	3A 125/250VAC (High Life)					02		E		2	S.P.S.T NC	C		2																	
							03		P		3				3																	
							04				4		D		4																	
											5				5																	
											6				6																	
<p>DIMENSIONS FOR C1 / C2 / C3 TYPE</p> <table border="1"> <tr> <th>CODE</th> <th>L1</th> <th>H</th> <th>ØA</th> <th>ØB</th> <th>ØC</th> <th>ØD</th> <th>P</th> </tr> <tr> <td>A</td> <td>3.15</td> <td>5.10</td> <td>2.05</td> <td>2.45</td> <td>2.05</td> <td>2.45</td> <td>6.50</td> </tr> </table>																	CODE	L1	H	ØA	ØB	ØC	ØD	P	A	3.15	5.10	2.05	2.45	2.05	2.45	6.50
CODE	L1	H	ØA	ØB	ØC	ØD	P																									
A	3.15	5.10	2.05	2.45	2.05	2.45	6.50																									
<p>DIMENSIONS FOR D4 / D5 / D6 TYPE</p> <table border="1"> <tr> <th>CODE</th> <th>L1</th> <th>H1</th> <th>H2</th> <th>ØA</th> <th>ØB</th> <th>P</th> </tr> <tr> <td>A</td> <td>1.95</td> <td>1.85</td> <td>2.05</td> <td>2.05</td> <td>2.60</td> <td>13.05</td> </tr> </table>																	CODE	L1	H1	H2	ØA	ØB	P	A	1.95	1.85	2.05	2.05	2.60	13.05		
CODE	L1	H1	H2	ØA	ØB	P																										
A	1.95	1.85	2.05	2.05	2.60	13.05																										

OPERATING CHARACTERISTICS

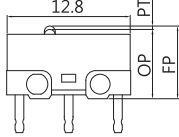
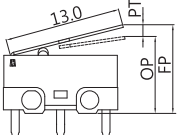
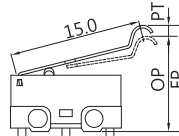
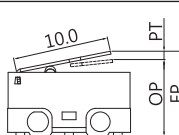
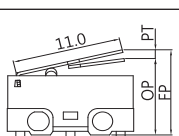
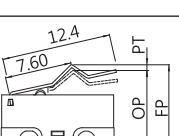
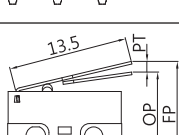
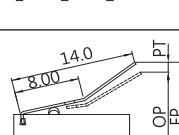
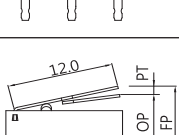
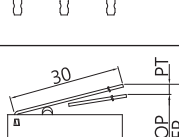
SWITCH TYPE	PART SUFFIX	OF Max. (gf)		OP (mm)	PT Max. (mm)	OT Min. (mm)	MD Max. (mm)	FP Max. (mm)	RF Min. (gf)
		L	S						
DF3- □□□ -0 □ -Z		L	80	7.0±0.2	0.5	0.2	0.12	7.50	21
		S	150						35
DF3- □□□ -1 □ -Z		L	30	8.2±0.8	3.4	0.6	0.8	10.1	5
		S	56						8
DF3- □□□ -2 □ -Z		L	25	10.2±0.8	3.5	0.7	0.92	14.2	5
		S	43						7
DF3- □□□ -3 □ -Z		L	40	7.9±0.5	2.1	0.3	0.4	9.3	5
		S	57						12
DF3- □□□ -4 □ -Z		L	36	8.0±0.6	2.5	0.5	0.7	10.8	6
		S	60						10
DF3- □□□ -5 □ -Z		L	50	9.2±0.6	1.64	0.49	0.3	10.15	7
		S	75						11
DF3- □□□ -6 □ -Z		L	30	8.33±0.9	3.5	0.6	0.8	10.6	5
		S	50						8
DF3- □□□ -7 □ -Z		L	27	10.75±0.9	3.5	0.3	0.8	13.5	3
		S	48						8
DF3- □□□ -8 □ -Z		L	33	8.15±0.7	2.8	0.6	0.7	11.2	5
		S	54						9
DF3- □□□ -9 □ -Z		L	13	9.5±1.7	6.9	0.55	1.9	16.8	2
		S	21						3

## CAUTIONS:

### 注意事項

1. To secure the switch, please use an M2 small screw on a flat surface and tighten with plane washers or spring washers to securely mount the switch, using a maximum torque of 0.1 N•m.  
若使用定位孔型式，請使用M2小型螺絲固定在平面上，並使用平墊圈或者彈性墊圈以便安全的鎖固開關，鎖固扭力請勿超過0.1 N•m.
2. To ensure the best performance of the switch, when handling/installing the switch, please do not apply uneven pressure to the direction indicated by the arrow in (Figure -1). Any uneven pressure or pressure direction other than the operating direction might be harmful or damage the switch performance.  
為確保開關正常運作，安裝及取用開關時，請勿直接施加壓力在(圖-1)中箭所指示的方向。如圖所示，任何不對稱的壓力或作動方向以外的壓力都不適在開關按柄上。
3. Do not exceed the end position (EP) and over travel (OT). This could cause operation failure.  
圖示設計按壓位置，請勿超過開關下死點及超出行程，以避免開關失效。

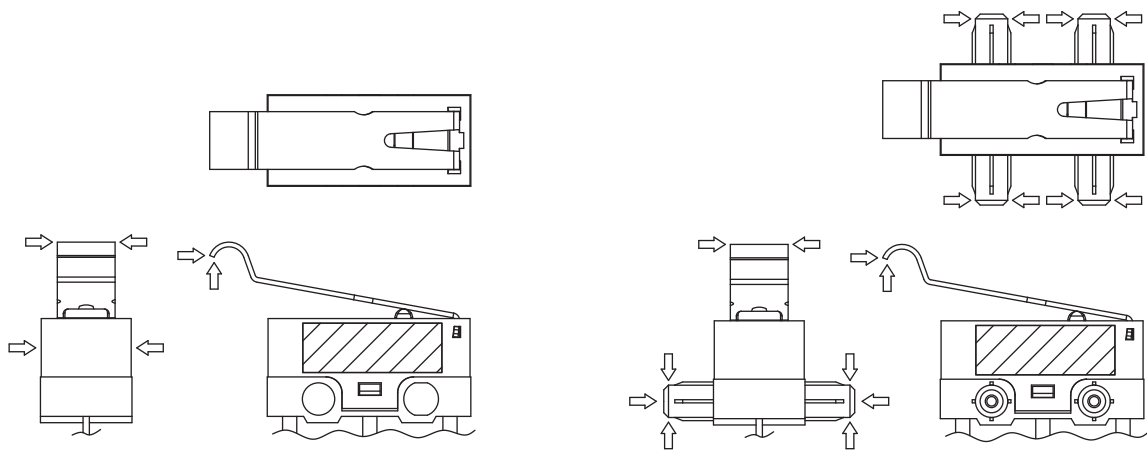
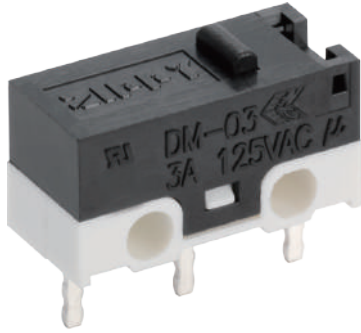

Figure-1

# MICRO SWITCHES



## DIMENSIONS

Unless otherwise specified, a tolerance of  $\pm 0.4\text{mm}$  applies to all dimensions.

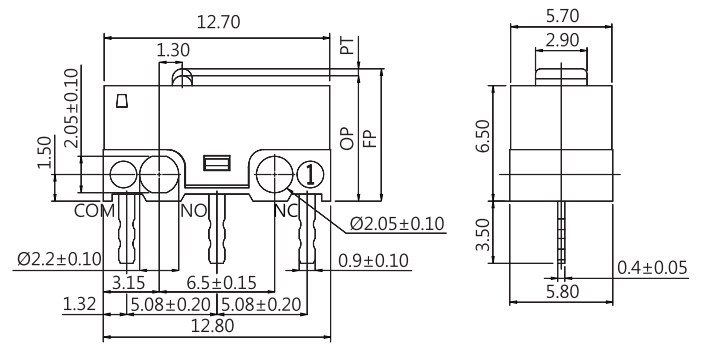

## DM SERIES

### SPECIFICATIONS

#### Contact Resistance(initial)

Max. 100 m $\Omega$

Measured by ohm meter - open voltage < 1VDC, driver current -100 mA

#### Insulation Resistance (at 500 VDC / minute)

Min. 100 M $\Omega$

#### Dielectric Strength

Min. 1000VAC(50-60HZ)/minute between Live parts.

Min. 1500VAC(50-60HZ)/minute between Live parts and dead metal parts

#### Operating Temperature Range

-40°C to 65°C ( with no icing )

#### Vibration

10~55Hz, displacement 0.75 mm (p-p)

#### Electrical Service Life

0.1A, 0.2A - Min. 1,000,000 operations

3A - Min. 10,000 operations

#### Electrical Operating Frequency

10~30 operations per minute

#### Mechanical Service Life

Min. 1,000,000 operations

#### Mechanical Operating Frequency

120 operations per minute

#### Operating application of the switch

Set the switch pushing distance from 60% to 90% of the specified OT value

### CONTACT CONFIGURATION

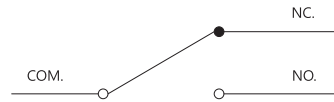

### MOUNTING HOLES FOR PCB TERMINAL

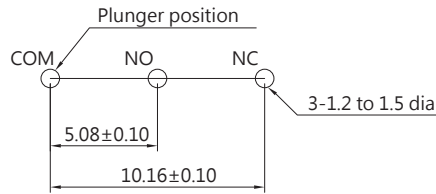

### CERTIFICATE INFORMATION

Model Name	UL, cUL	ENEC
DM-03	0.1A 48VDC 0.2A 60VDC 0.1A 125VAC 3A 125VAC (Temp:65°C) Min. 10,000 operations	3A 125VAC $\mu$ T55 1E4

### APPLICATIONS

Walkie talkie, Mouse, Electric knife, Electric stapler, Telephone, Calculator, Mixer & chopper, Electric pan, Battery charger, Video cassette reminder, Cordless phone, Tester machine

### THE SELECTION OF RATING & FORCE

Model	Rating	L	S
DM	0.1A	*	*
	0.2A	*	*
	3A	*	*

NOTE : The Symbol " \* " to represent the result is accepted

TERMINAL TYPES

C TYPE

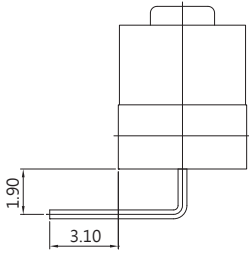

D TYPE

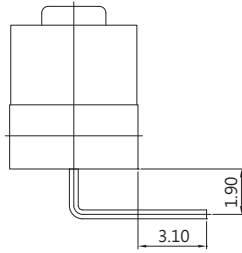

E TYPE

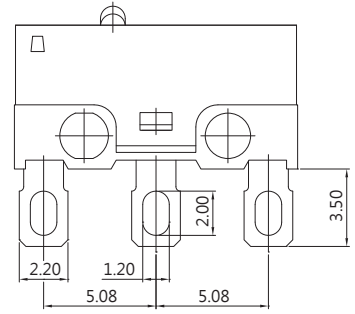

F TYPE

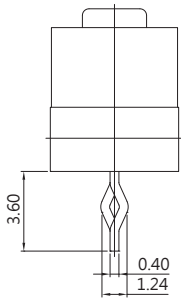

P TYPE

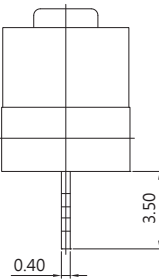

ORDERING INFORMATION

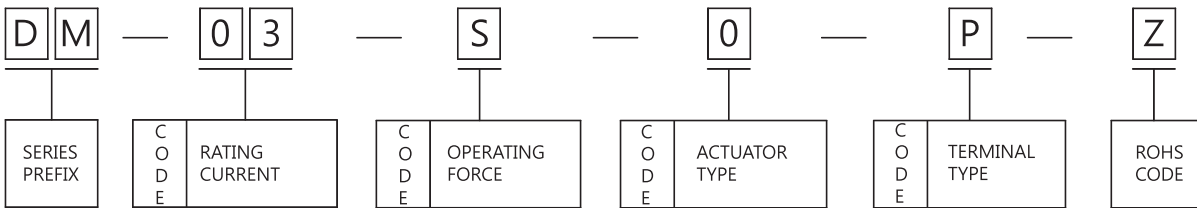

Note1.  
for special type DM-03□-□□ - A gold plated contacts rating 0.1A 48VDC ; 0.1A 125VAC ; 0.2A 60VDC ; 1A 125VAC ; 3A 125VAC.

OPERATING CHARACTERISTICS

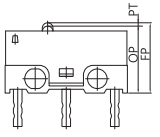
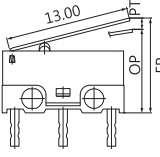
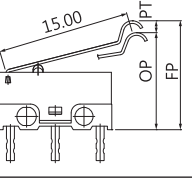
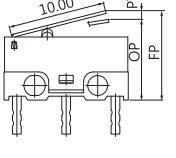
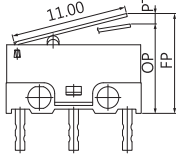
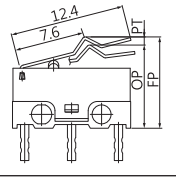
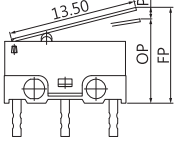
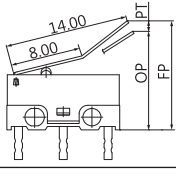
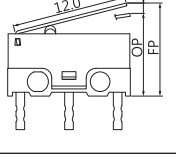
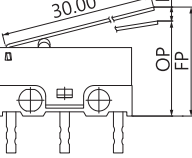
SWITCH TYPE	PART SUFFIX	OF Max. (gf)		OP (mm)	PT Max. (mm)	OT Min. (mm)	MD Max. (mm)	FP Max. (mm)	RF Min. (gf)
		L	S						
DM-03 □ -0 □ -Z		L	90	7.0±0.3	1.3	0.2	0.3	8.0	15
		S	150						20
DM-03 □ -1 □ -Z		L	30	8.4±0.8	3.4	0.6	1.3	11.0	5
		S	50						8
DM-03 □ -2 □ -Z		L	27	10.5±0.8	3.8	0.6	1.5	13.5	4
		S	45						7
DM-03 □ -3 □ -Z		L	40	7.9±0.8	3.4	0.6	1.0	10.5	6
		S	70						10
DM-03 □ -4 □ -Z		L	36	8.1±0.8	3.4	0.6	1.1	10.7	5
		S	65						9
DM-03 □ -5 □ -Z		L	53	8.9±0.8	2.9	0.6	0.8	11.0	8
		S	88						12
DM-03 □ -6 □ -Z		L	29	8.5±0.8	3.5	0.7	1.4	11.2	4
		S	50						7
DM-03 □ -7 □ -Z		L	29	11.3±1.0	3.7	0.3	1.4	14.0	4
		S	50						7
DM-03 □ -8 □ -Z		L	33	8.2±0.8	3.4	0.5	1.2	10.8	5
		S	60						8
DM-03 □ -9 □ -Z		L	15	10.79±2.1	10.1	0.9	3.0	16.9	2
		S	22	8.9±2.1					3

## CAUTIONS:

### 注意事項

1. To secure the switch, please use an M2 small screw on a flat surface and tighten with plane washers or spring washers to securely mount the switch, using a maximum torque of 0.1 N•m.  
若使用定位孔型式，請使用M2小型螺絲固定在平面上，並使用平墊圈或者彈性墊圈以便安全的鎖固開關，鎖固扭力請勿超過0.1 N•m.
2. To ensure the best performance of the switch, when handling/installing the switch, please do not apply uneven pressure to the direction indicated by the arrow in (Figure -1). Any uneven pressure or pressure direction other than the operating direction might be harmful or damage the switch performance.  
為確保開關正常運作，安裝及取用開關時，請勿直接施加壓力在(圖-1)中箭所指示的方向。如圖所示，任何不對稱的壓力或作動方向以外的壓力都不適在開關按柄上。
3. Do not exceed the end position (EP) and over travel (OT). This could cause operation failure.  
圖示設計按壓位置，請勿超過開關下死點及超出行程，以避免開關失效。

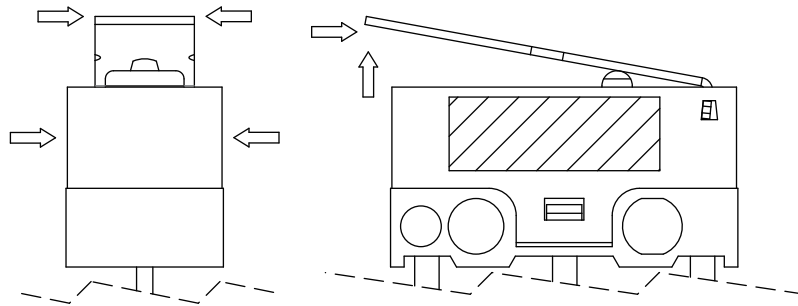

Figure-1



# MICRO SWITCHES



## DW51 (IP50) SERIES

### SPECIFICATIONS

#### Contact Resistance(initial)

Max. 100 mΩ

Measured by ohm meter - open voltage <1 VDC, driver current -100 mA

#### Insulation Resistance ( at 500VDC/minute )

Min. 100MΩ

#### Dielectric Strength

Min. 400VAC(50-60HZ)/minute between Live parts.

Min. 1300VAC(50-60HZ)/minute between Live parts and dead metal parts

#### Operating Temperature Range

-40°C to 85°C ( with no icing )

#### Vibration

10~55Hz, displacement 0.75 mm (p-p)

#### Electrical Service Life

0.1A - Min. 100,000 operations

3A - Min. 10,000 operations

#### Electrical Operating Frequency

10~30 operations per minute

#### Mechanical Service Life

Min. 500,000 operations

#### Mechanical Operating Frequency

120 operations per minute

#### Operating application of the switch

Set the switch pushing distance from 60% to 90% of the specified OT value

### APPLICATIONS

Automotive (Seat Belt, Door Latch, Engine Hood, Door Trunk), Air Conditioner, Communication, Security System, Electric Tooth Brush, Toy

### DIMENSIONS

Unless otherwise specified, a tolerance of  $\pm 0.4$ mm applies to all dimensions.

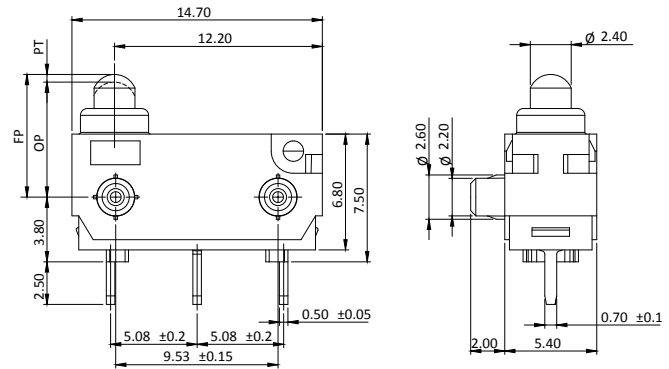

### CONTACT CONFIGURATION

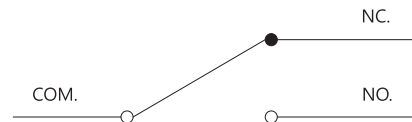

### MOUNTING HOLES FOR PCB TERMINAL

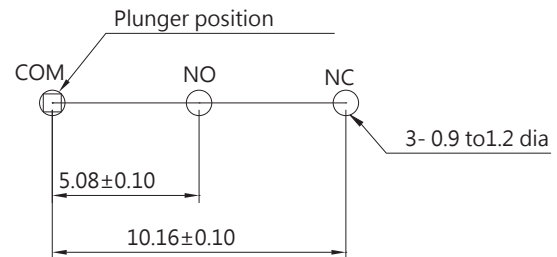

### PILLAR PITCH

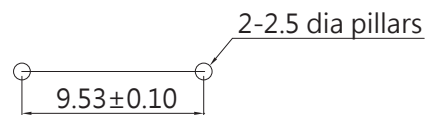

### CERTIFICATE INFORMATION

Model Name	UL, cUL	ENEC
DW51-P1 or G1	0.1RA 12 VDC, $\mu$ T55 1E5 0.1RA 125 VAC, $\mu$ T55 1E4	0.1A 12 VDC, $\mu$ T55 1E5 0.1A 125 VAC, $\mu$ T55 1E4
DW51-03 or G3	3RA 12 VDC, $\mu$ T55 1E5 3GPA 125 VAC, $\mu$ T55 1E4	3A 12 VDC, $\mu$ T55 1E5 3A 125 VAC, $\mu$ T55 1E4

TERMINAL TYPES (THE thickness of each terminal is 0.5mm)

P TYPE

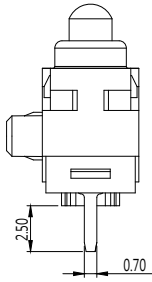

COVER TYPES (PILLAR & TRAVEL TYPES)

A TYPE

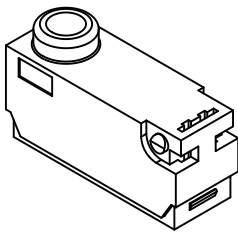

B TYPE

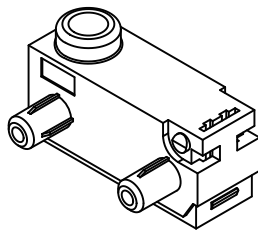

C TYPE

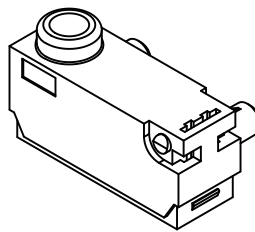

D TYPE

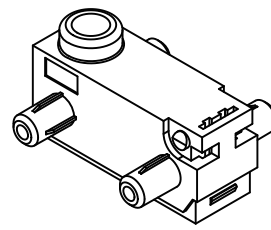

ORDERING INFORMATION

D	W	S	1	0	3	S	1	0	1	P	0	A	0	A	Z						
SERIES PREFIX				RATING CURRENT		OPERATING FORCE		COVER & BUTTON TYPE		ACTUATOR TYPE		TERMINAL TYPE		CIRCUIT ARRANGEMENT		PILLAR TYPE		SPECIAL CODE		ROHS CODE	
				G1 0.1A 125VAC Contact plated gold		S STANDARD		1		00		P		0 S.P.D.T		A					
				P1 0.1A 125VAC						01				1 S.P.S.T NO		B					
				G3 3A 125VAC Contact plated gold										2 S.P.S.T NC		C					
				03 3A 125VAC												D					

DIMENSIONS							
CODE	L1	H	ΦA	ΦB	ΦC	ΦD	P
A	5.0	3.7	2.2	2.6	2.2	2.6	9.53
B	2.0	3.7	2.2	2.6	2.2	2.6	9.53
B	3.5	3.7	2.2	2.6	2.2	2.6	9.53

OPERATING CHARACTERISTICS

SWITCH TYPE	PART SUFFIX	OF Max (gf)	OP (mm)	PT Max (mm)	OT Min (mm)	MD Max (mm)	FP Max (mm)	RF Min (gf)
DW51- □□ S1-00 □□ -Z		S	130	3.05±0.2	0.8	0.8	0.3	3.65
				6.75±0.2				7.35
DW51- □□ S1-01 □□ -Z		S	195	3.7±0.5	3.85	1.35	0.5	7.0
				7.4±0.5				10.7
DW51- □□ S1-04 □□ -Z		S	160	6.2±0.8	4.8	1.65	0.7	10.1
				9.9±0.8				13.8

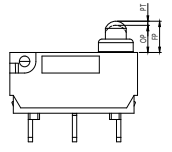
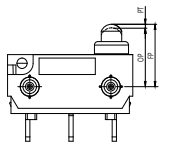
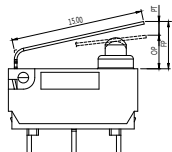
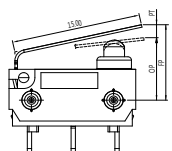
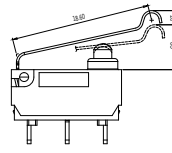
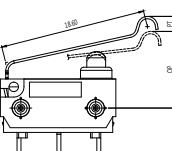
**CAUTIONS:**  
注意事項

1. Do not handle the switch in a way that may cause damage to the switch sealing.  
使用開關時，請勿損壞開關防水膠。
2. To ensure the best performance of the switch, when handling/installing the switch, please do not apply uneven pressure to the direction indicated by the arrow in Figure 1. Any uneven pressure or pressure direction other than the operating direction might be harmful or damage the switch performance.  
為確保開關正常運作，安裝及取用開關時，請勿直接施加壓力在圖-1中箭頭所指示的方向。如圖所示，任何不對稱的壓力或作動方向以外的壓力都不適用在開關按柄上。
3. Do not exceed the end position (EP) and over travel (OT). This could cause operation failure. (Figure-2)  
圖示設計按壓位置，請勿超過開關下死點及超出行程，以避免開關失效。(圖2)

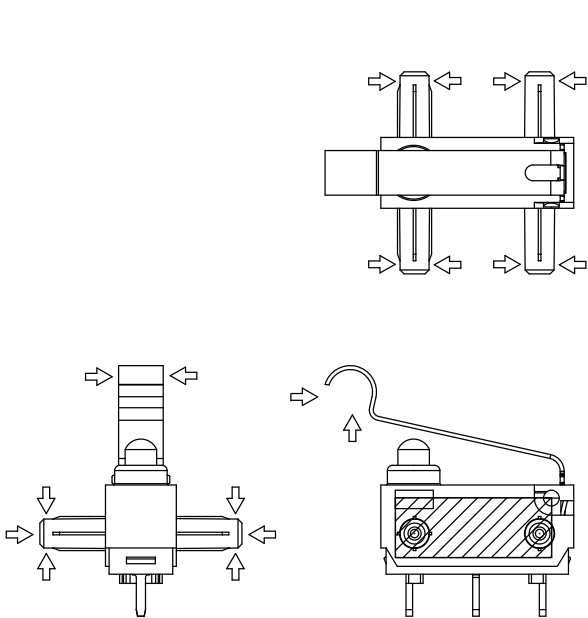

Figure-1

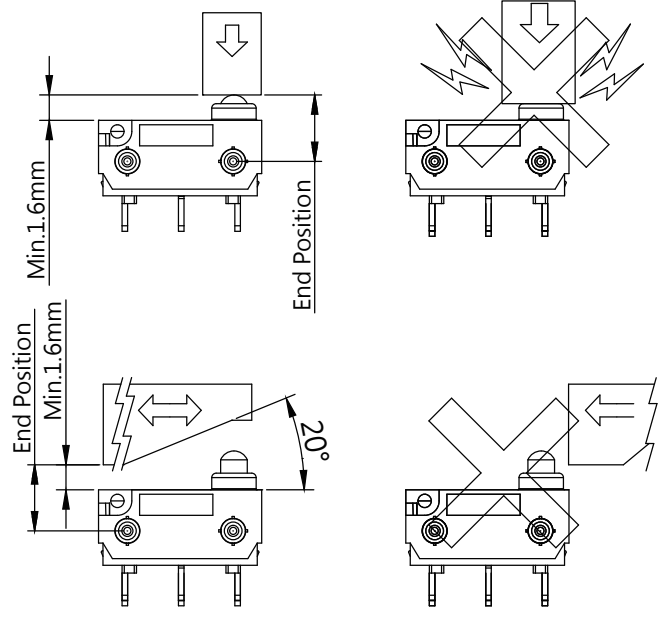
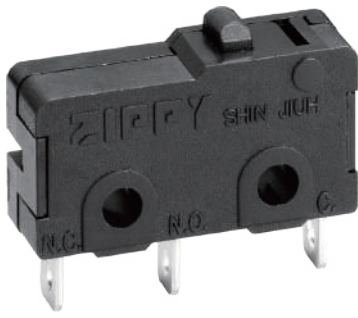

Figure-2

# MICRO SWITCHES



## DIMENSIONS

Unless otherwise specified, a tolerance of  $\pm 0.4\text{mm}$  applies to all dimensions.

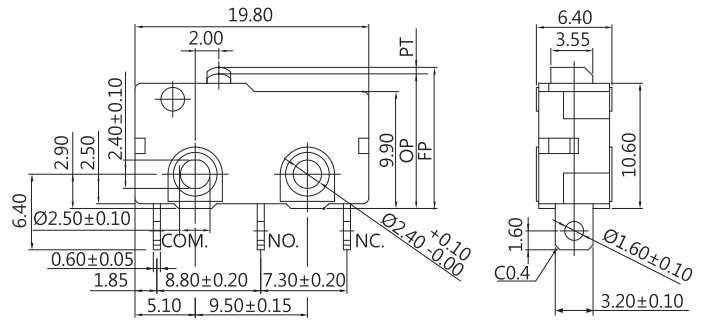

## SM SERIES

### SPECIFICATIONS

#### Contact Resistance(initial)

Max. 300 m $\Omega$

Measured by ohm meter - open voltage < 1VDC, driver current -100 mA

#### Insulation Resistance (at 500 VDC / minute)

Min. 100 M $\Omega$

#### Dielectric Strength

Min. 1000VAC(50-60HZ)/minute between Live parts.

Min. 1250VAC(50-60HZ)/minute between Live parts and dead metal parts

#### Operating Temperature Range

-40°C to 120°C ( with no icing )

#### Vibration

10~55Hz, displacement 0.75 mm (p-p)

#### Electrical Service Life

0.1A - Min. 1,000,000 operations

Other rating - Min. 10,000 operations

#### Electrical Operating Frequency

10~30 operations per minute

#### Mechanical Service Life

Min. 10,000,000 operations

#### Mechanical Operating Frequency

120 operations per minute

#### Operating application of the switch

Set the switch pushing distance from 60% to 90% of the specified OT value

### CONTACT CONFIGURATION

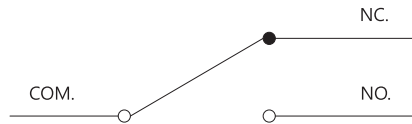

### CERTIFICATE INFORMATION

Model Name	UL, cUL
SM-P1	0.1A 125/250VAC 0.1A 30VDC (Temp:120°C) Min. 10,000 operations
SM-G1	0.1A 125/250VAC 0.1A 30VDC (Temp:120°C) Min. 10,000 operations
SM-05	5A 125/250VAC 5A 30VDC (Temp:120°C) Min. 10,000 operations
SM-G5	5A 125/250VAC 5A 30VDC (Temp:120°C) Min. 10,000 operations

### APPLICATIONS

Telephone, Air conditioner, Computer, Humidifier, Alarm, Time recorder, Mixer & Chopper, Solder gun, Neon phone, Fax machine, Joystick, Water pump, Gas detector, Pencil sharpener, Money sorter, Food processor, Electric knife, Toy car, Juicer, Electric steak pan.

### THE SELECTION OF RATING & FORCE

MODEL	Rating	D	L	S	H	Q	T
SM	0.1A	*	*	*	*	*	*
	5A			*	*	*	*

NOTE : The Symbol " \* " to represent the result is accepted

**TERMINAL TYPES (The thickness of each terminal is 0.6mm)**

A TYPE

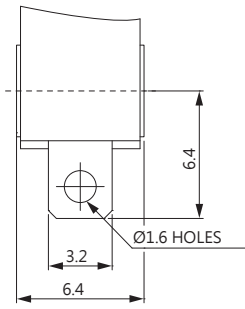

B TYPE

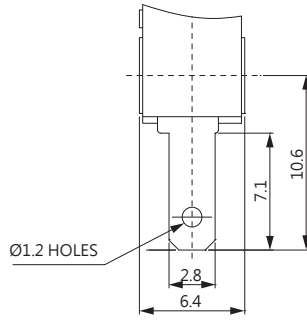

C TYPE

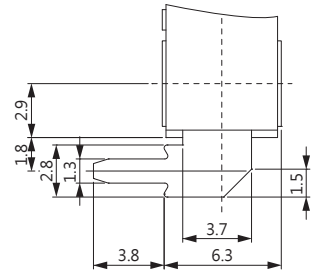

D TYPE

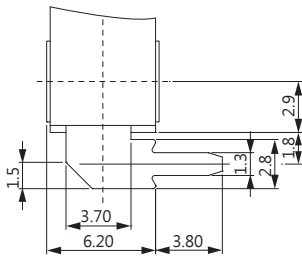

E TYPE

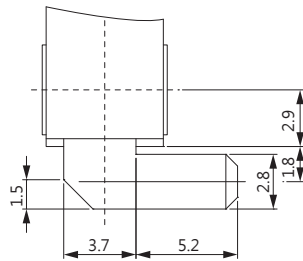

P TYPE

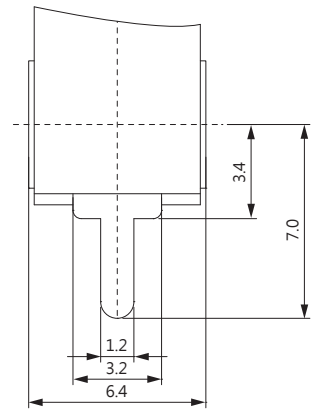

**MOUNTING HOLES**

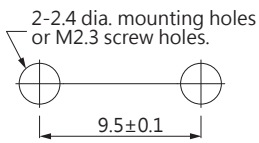

**MOUNTING HOLES FOR PCB TERMINAL**

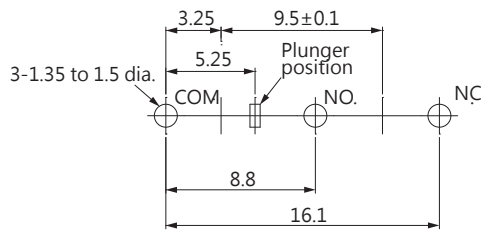

**ORDERING INFORMATION**

<b>S</b>	<b>M</b>	<b>0</b>	<b>5</b>	<b>S</b>	<b>0</b>	<b>3</b>	<b>P</b>	<b>0</b>	<b>Z</b>		
SERIES PREFIX	C O D E	RATING CURRENT	C O D E	OPERATING FORCE	C O D E	ACTUATOR TYPE	C O D E	TERMINAL TYPE	C O D E	CIRCUIT ARRANGEMENT	ROHS CODE
	P1	0.1A 125/250VAC		T MAX HEAVIER	00		A		0	S.P.D.T.	
	05	5A 125/250VAC		Q HEAVIER	01		B		1	S.P.S.T. NO	
				H HEAVY	02		C		2	S.P.S.T. NC	
				S STANDARD	03		D				
				L LIGHT	04		E				
				D SLIGHT		⋮	P				

#NOTE		
ITEM	RATING CURRENT	OPERATING FORCE
1	Code:P1	T,Q,H,S,L,D
2	Code:05	T,Q,H,S

OPERATING CHARACTERISTICS

SWITCH TYPE	PART SUFFIX	OF Max. (gf)		OP (mm)	PT Max. (mm)	OT Min. (mm)	MD Max. (mm)	FP Max. (mm)	RF Min. (gf)
		H	S						
SM- □□□ -00 □□ -Z		H	249	11.4±0.3	1.1	0.4	0.2	12.2	50
		S	146						35
		L	104						20
SM- □□□ -01 □□ -Z		H	66	11.8±0.8	3.6	0.6	0.8	14.6	9
		S	40						6
		L	30						3
SM- □□□ -02 □□ -Z		H	58	11.8±0.9	4.0	0.6	0.8	14.9	9
		S	36						6
		L	25						6
SM- □□□ -03 □□ -Z		H	45	11.8±1.5	6.1	0.8	1.5	16.4	6
		S	28						4
		L	20						5
SM- □□□ -04 □□ -Z		H	56	13.7±1.0	4.6	0.8	0.8	17.3	13
		S	34						8
		L	25						5
SM- □□□ -05 □□ -Z		H	60	17.5±0.8	3.8	0.8	0.8	20.5	15
		S	35						8
		L	25						6
SM- □□□ -06 □□ -Z		H	48	19.0±1.5	5.7	1.0	1.0	23.2	10
		S	28						6
		L	20						4
SM- □□□ -07 □□ -Z		H	30	11.8±2.0	8.6	1.5	1.8	18.4	7
		S	20						4
		L	15						2
SM- □□□ -08 □□ -Z		H	30	-2.3±3.0	6.0	1.0	1.9	5.4	3
		S	20						4
		L	15						2
SM- □□□ -09 □□ -Z		H	18	11.8±3.0	13.3	1.0	2.9	22.1	4
		S	12						2.5
		L	8						1.5

## CAUTIONS:

### 注意事項

1. To secure the switch, please use an M2.3 small screw on a flat surface and tighten with plane washers or spring washers to securely mount the switch, using a maximum torque of 0.26 N•m.  
若使用定位孔型式，請使用M2.3小型螺絲固定在平面上，並使用平墊圈或者彈性墊圈以便安全的鎖固開關，鎖固扭力請勿超過0.26 N•m.
2. To ensure the best performance of the switch, when handling/installing the switch, please do not apply uneven pressure to the direction indicated by the arrow in (Figure -1). Any uneven pressure or pressure direction other than the operating direction might be harmful or damage the switch performance.  
為確保開關正常運作，安裝及取用開關時，請勿直接施加壓力在(圖-1)中箭所指示的方向。如圖所示，任何不對稱的壓力或作動方向以外的壓力都不適在開關按柄上。

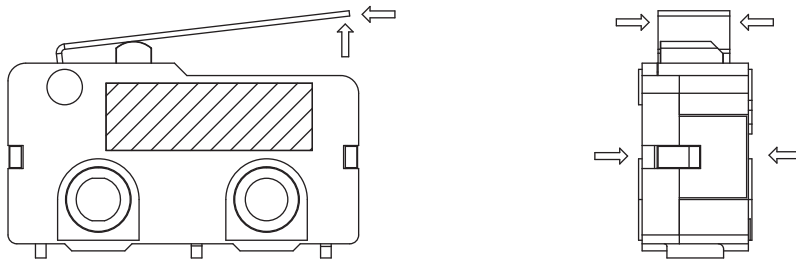

Figure-1



# MICRO SWITCHES



internal snap-fit lever



external snap-fit lever

## SM1 SERIES

### SPECIFICATIONS

#### Contact Resistance(initial)

Max. 300 mΩ

(Measured by ohm meter-open voltage<1VDC, driver current-100 mA)

#### Insulation Resistance ( at 500VDC/minute )

Min. 100MΩ

#### Dielectric Strength

Min. 500VAC(50-60HZ)/minute between Live parts.

Min. 1500VAC(50-60HZ)/minute between Live parts and dead metal parts

#### Operating Temperature Range

SM1-06/10/16 series : -40°C to 125°C ( with no icing )

SM1-C1/C3/C5 series: -40°C to 85°C ( with no icing )

SM1-S5 series: -40°C to 55°C ( with no icing )

#### Vibration

10~55Hz, displacement 0.75 mm (p-p)

#### Electrical Service Life

Min. 10,000 operations

#### Electrical Operating Frequency

10~30 operations per minute

#### Mechanical Service Life

All series for H force: No define the life cycles

All series for F force and SM1-10S: Min. 1,000,000 operations

Others : Min. 10,000,000 operations

#### Mechanical Operating Frequency

120 operations per minute

#### Operating application of the switch

Set the switch pushing distance from 60% to 90% of the specified OT value

### APPLICATIONS

Telephone, Air conditioner, Computer, Humidifier, Alarm, Time recorder, Mixer & Chopper, Solder gun, Neon phone, Fax machine, Joystick, Water pump, Gas detector, Pencil sharpener, Money sorter, Food processor, Electric knife, Toy car, Juice maker, Electric steak pan

### DIMENSIONS

Unless otherwise specified, a tolerance of ±0.4mm applies to all dimensions

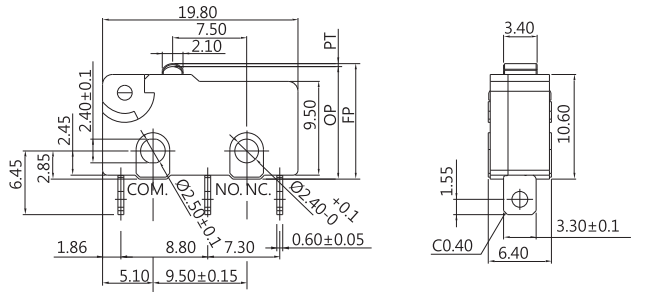
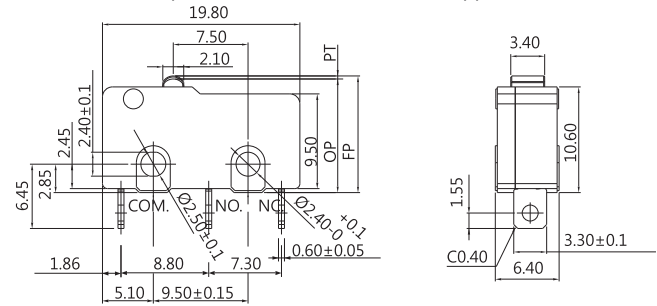

### CONTACT CONFIGURATION



### MOUNTING HOLES

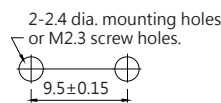

### MOUNTING HOLES FOR PCB TERMINAL

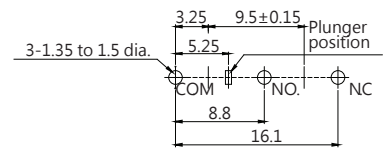

### CERTIFICATE INFORMATION

Model Name	UL, cUL	ENEC
SM1-06	6A 125/250VAC (Temp: 125°C) Min. 10,000 operations	6A 125/250VAC μ 40T125 1E4 6(2)A 125/250VAC μ 40T125 1E4
SM1-10	10.1A 125/250VAC (Temp: 125°C) Min. 10,000 operations	10.1A 125/250VAC μ 40T125 1E4 6(2)A 125/250VAC μ 40T125 1E4
SM1-16	16A 125/250VAC (Temp: 125°C) Min. 10,000 operations	16.1A 125/250VAC μ 40T125 1E4 6(3)A 125/250VAC μ 40T125 1E4
SM1-C1	0.1A 125/250VAC (Temp: 85°C) Min. 10,000 operations	0.1A 125/250VAC μ T85 1E4
SM1-C3	3A 125/250VAC (Temp: 85°C) Min. 10,000 operations	3A 125/250VAC μ T85 1E4
SM1-C5	5A 125/250VAC (Temp: 85°C) Min. 10,000 operations	5A 125/250VAC μ T85 1E4
SM1-S5S	5RA 125/250VAC uT55 1E5	5A 125/250VAC uT55 1E5

### THE SELECTION OF RATING & FORCE

Model Name	Rating	D	L	S	F	H
SM1	5A	*	*	*	*	*
	6A	*	*	*	*	*
	10.1A			*	*	*
	16A					*

NOTE : The Symbol " \* " to represent the result is accepted for AC

TERMINAL TYPES ( The thickness of terminal is 0.6 mm, beside G type terminal )

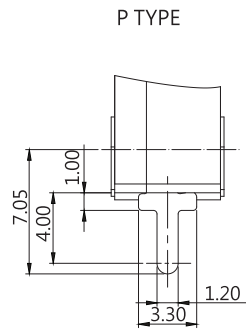
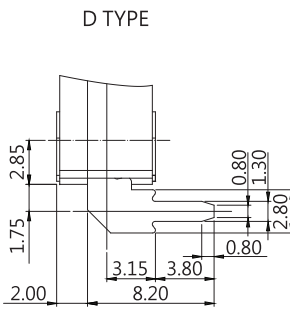
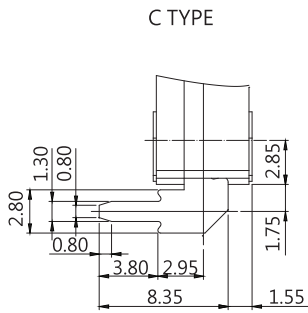
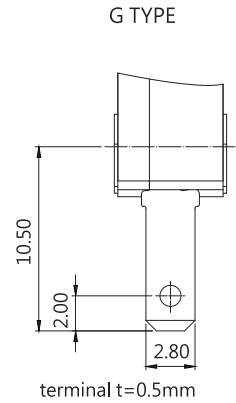
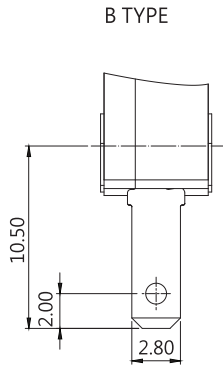
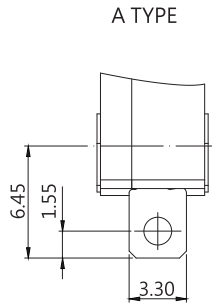

ORDERING INFORMATION

S M 1 - 0 6

SERIES PREFIX	C O D E	RATING CURRENT
	06	6A 125/250VAC 6(2)A 125/250VAC
	10	10.1A 125/250VAC 6(2)A 125/250VAC
	16	16A 125/250VAC 6(3)A 125/250VAC
	C1	0.1A 125/250VAC
	C3	3A 125/250VAC
	C5	5A 125/250VAC
	S5	5A 125/250VAC HIGH LIFE

S

C O D E	OPERATING FORCE
S	STANDARD
L	LIGHT
D	SLIGHT
F	HEAVY
H	HEAVIER

INTERNAL SNAP-FIT LEVER		OR	EXTERNAL SNAP-FIT LEVER	
C O D E	ACTUATOR TYPE		C O D E	ACTUATOR TYPE
00			500	
01			01	
02			02	
03			03	
04			04	
05			05	
06			06	
07			07	
08			08	
09			09	

A 0 - Z

C O D E	TERMINAL TYPE	C O D E	CONTACT ARRANGEMENT	ROHS CODE
A		0	S.P.D.T	
B		1	S.P.S.T NO	
C		2	S.P.S.T NC	
D				
P				
G				

NOTE#	ITEM	RATING CURRENT	OPERATING FORCE
1	CODE:06		ALL
2	CODE:10		S,H,F
3	CODE:16		H
4	CODE:C1		ALL
5	CODE:C3		ALL
6	CODE:C5		ALL
7	CODE:S5		S

OPERATING CHARACTERISTICS ( SM1 series - internal snap-fit lever )

SWITCH TYPE	PART SUFFIX	OF Max. (gf)		OP (mm)	PT Max. (mm)	OT Min. (mm)	MD Max. (mm)	FP Max. (mm)	RF Min. (gf)
		H	F						
SM1- □□□ -00 □□ -Z		H	355	11.4±0.3	1.1	0.4	0.2	12.2	100
		F	280						50
		S	150						25
		L	95						10
SM1- □□□ -01 □□ -Z		H	118	11.4±1.1	4.63	0.53	1.45	14.6	20
		F	90	11.8±0.8	3.6	0.6	0.8		9
		S	50						6
		L	28						1
SM1- □□□ -02 □□ -Z		H	107					11.4±1.3	5.29
		F	82	11.8±0.9	4.03	0.67	0.9	8	
		S	45					5	
		L	25					1	
SM1- □□□ -03 □□ -Z		H	87					11.0±1.8	7.47
		F	70	11.8±1.5	5.35	0.89	1.19	5	
		S	34					2	
		L	20					1	
SM1- □□□ -04 □□ -Z		H	111					13.3±1.2	5.02
		F	85	13.7±0.9	3.86	0.64	0.86	8	
		S	47					5	
		L	26					1	
SM1- □□□ -05 □□ -Z		H	117					17.1±1.1	4.60
		F	90	17.5±0.8	3.8	0.6	0.8	9	
		S	50					6	
		L	28					1	
SM1- □□□ -06 □□ -Z		H	97					18.0±1.5	6.12
		F	75	19.0±1.5	5.7	1.0	1.0	7	
		S	42					2	
		L	23					1	
SM1- □□□ -07 □□ -Z		H	55					9.9±2.7	11.20
		F	53	11.8±2.0	8.6	1.5	1.8	3	
		S	25					1	
		L	16					1	
SM1- □□□ -08 □□ -Z		F	58					-2.3±3.0	6.0
		S	25	1					
		L	17	1					
SM1- □□□ -09 □□ -Z		F	38	11.8±3.0	13.3	1.0	2.9	22.1	2
		S	15						2
		L	12						1

OPERATING CHARACTERISTICS ( SM1 series - external snap-fit lever )

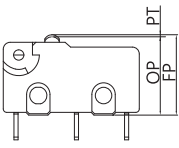
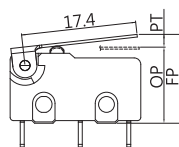
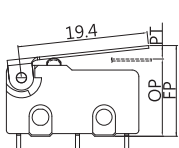
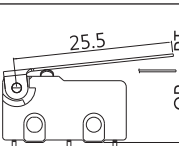
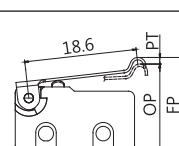
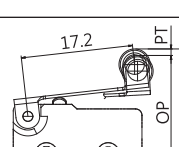
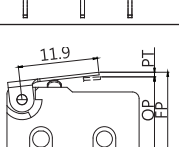
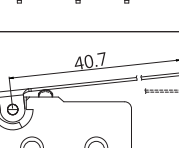
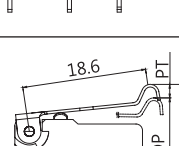
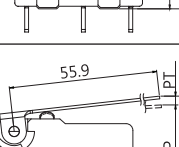
SWITCH TYPE	PART SUFFIX	OF Max. (gf)		OP (mm)	PT Max. (mm)	OT Min. (mm)	MD Max. (mm)	FP Max. (mm)	RF Min. (gf)
		H	F						
SM1-□□□-500□□-Z		H	355	11.4±0.3	1.1	0.4	0.2	12.2	100
		F	280						50
		S	150						25
		L	95						10
SM1-□□□-501□□-Z		H	120	11.8±1.10	4.6	0.9	0.8	15.3	15
		F	105						12
		S	50						6
		L	40						1
SM1-□□□-502□□-Z		H	120	11.8±1.20	5.1	0.7	0.8	15.70	10
		F	100						8
		S	50						5
		L	40						--
SM1-□□□-503□□-Z		H	100	11.8±1.60	6.90	0.9	1.10	17.10	10
		F	80						7
		S	45						4
		L	35						--
SM1-□□□-504□□-Z		H	120	13.7±1.1	4.80	1.50	0.8	17.40	15
		F	100						11
		S	50						6
		L	40						1
SM1-□□□-505□□-Z		H	145	17.9±1.0	4.05	0.55	0.9	21.00	15
		F	110						12
		S	55						6
		L	40						1
SM1-□□□-506□□-Z		H	195	11.8±0.8	3.2	0.6	0.6	14.2	25
		F	145						19
		S	70						10
		L	50						2
SM1-□□□-507□□-Z		H	80	11.8±2.6	10.8	1.2	1.9	20.0	5
		F	60						3
		S	35						1
		L	30						---
SM1-□□□-508□□-Z		H	120	14.9±1.1	4.10	1.0	0.8	17.95	40
		F	100						11
		S	50						3
		L	40						1
SM1-□□□-509□□-Z		H	65	11.8±3.5	14.8	2.8	2.6	23.1	1
		F	50						1
		S	30						1
		L	25						---

## CAUTIONS:

### 注意事項

1. To secure the switch, please use an M2.3 small screw on a flat surface and tighten with plane washers or spring washers to securely mount the switch, using a maximum torque of 0.26 N•m.  
若使用定位孔型式，請使用M2.3小型螺絲固定在平面上，並使用平墊圈或者彈性墊圈以便安全的鎖固開關，鎖固扭力請勿超過0.26 N•m.
2. To ensure the best performance of the switch, when handling/installing the switch, please do not apply uneven pressure to the direction indicated by the arrow in (Figure -1). Any uneven pressure or pressure direction other than the operating direction might be harmful or damage the switch performance.  
為確保開關正常運作，安裝及取用開關時，請勿直接施加壓力在(圖-1)中箭所指示的方向。如圖所示，任何不對稱的壓力或作動方向以外的壓力都不適在開關按柄上。
3. Do not exceed the end position (EP) and over travel (OT). This could cause operation failure.(Figure -2)  
圖示設計按壓位置，請勿超過開關下死點及超出行程，以避免開關失效。(圖-2)

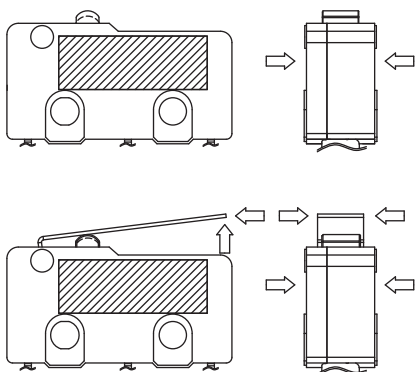

Figure-1

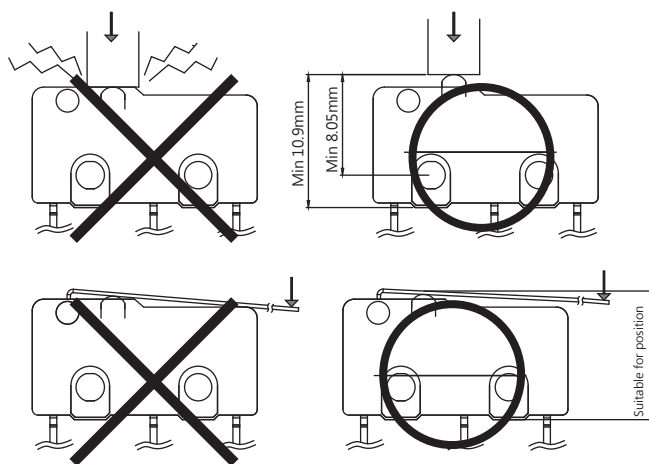

Figure-2

# MICRO SWITCHES



Internal snap-fit lever



External snap-fit lever

## DIMENSIONS

Unless otherwise specified, a tolerance of  $\pm 0.4\text{mm}$  applies to all dimensions.

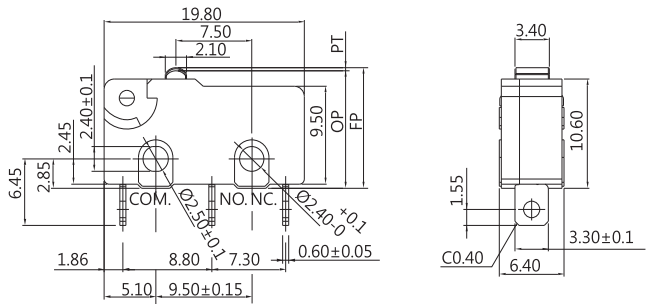
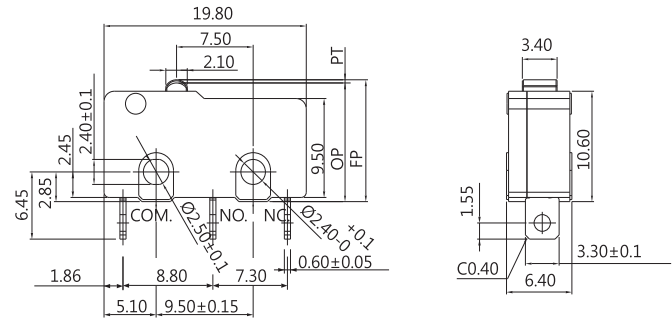

## CONTACT CONFIGURATION



## SM1-N & SM1-G SERIES

### SPECIFICATIONS

#### Contact Resistance(initial)

Max. 300 m $\Omega$

(Measured by ohm meter-open voltage < 1VDC, driver current-100 mA)

#### Insulation Resistance ( at 500VDC/minute )

Min. 100M $\Omega$

#### Dielectric Strength

Min. 500VAC(50-60HZ)/minute between Live parts.

Min. 1500VAC(50-60HZ)/minute between Live parts and dead metal parts

#### Operating Temperature Range

-40°C to 125°C ( with no icing )

#### Vibration

10~55Hz, displacement 0.75 mm (p-p)

#### Electrical Service Life

Min. 10,000 operations

#### Electrical Operating Frequency

10~30 operations per minute

#### Mechanical Service Life

All series for H force: No define the life cycles

All series for F force: Min. 1,000,000 operations

Others: Min. 5,000,000 operations

#### Mechanical Operating Frequency

120 operations per minute

#### Operating application of the switch

Set the switch pushing distance from 60% to 90% of the specified OT value

### APPLICATIONS

Telephone, Air conditioner, Computer, Humidifier, Alarm, Time recorder, Mixer & Chopper, Solder gun, Neon phone, Fax machine, Joystick, Water pump, Gas detector, Pencil sharpener, Money sorter, Food processor, Electric knife, Toy car, Juice maker, Electric steak pan.

### MOUNTING HOLES

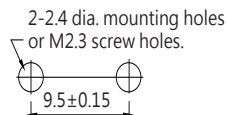

### MOUNTING HOLES FOR PCB TERMINAL

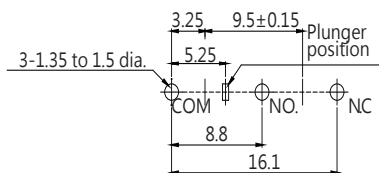

### CERTIFICATE INFORMATION

Model Name	UL, cUL	ENEC
SM1-G1 SM1-NC1 SM1-GC1	0.1RA 125/250VAC $\mu$ T125 1E4 0.1RA 30VDC $\mu$ T125 1E4	0.1A 125/250VAC $\mu$ T125 1E4 0.1A 30VDC $\mu$ T125 1E4
SM1-N3 SM1-G3 SM1-NC3 SM1-GC3	3RA 125/250VAC $\mu$ T125 1E4 3RA 30VDC $\mu$ T125 1E4	3A 125/250VAC $\mu$ T125 1E4 3A 30VDC $\mu$ T125 1E4
SM1-N6 SM1-G6	6RA 125/250VAC $\mu$ T125 1E4 6GPA 125/250VAC $\mu$ T85 1E4 5RA 30VDC $\mu$ T125 1E4	6A 125/250VAC $\mu$ T125 1E4 5A 30VDC $\mu$ T125 1E4 6(3)A 125/250VAC $\mu$ T85 1E4 ( S,F, H force only )

### THE SELECTION OF RATING & FORCE

Model Name	Rating	D	L	S	F	H
SM1-G1 SM1-NC1 or SM1-GC1	0.1A	*	*	*	*	*
SM1-N3 or SM1-G3	3A	*	*	*	*	*
SM1-NC3 or SM1-GC3	3A		*	*	*	*
SM1-N6 or SM1-G6	6A	*	*	*	*	*
SM1-N6S, N6F, N6H	6(3)A			*	*	*

NOTE : The Symbol " \* " to represent the result is accepted for AC

TERMINAL TYPES ( The thickness of terminal is 0.6 mm, beside G type terminal )

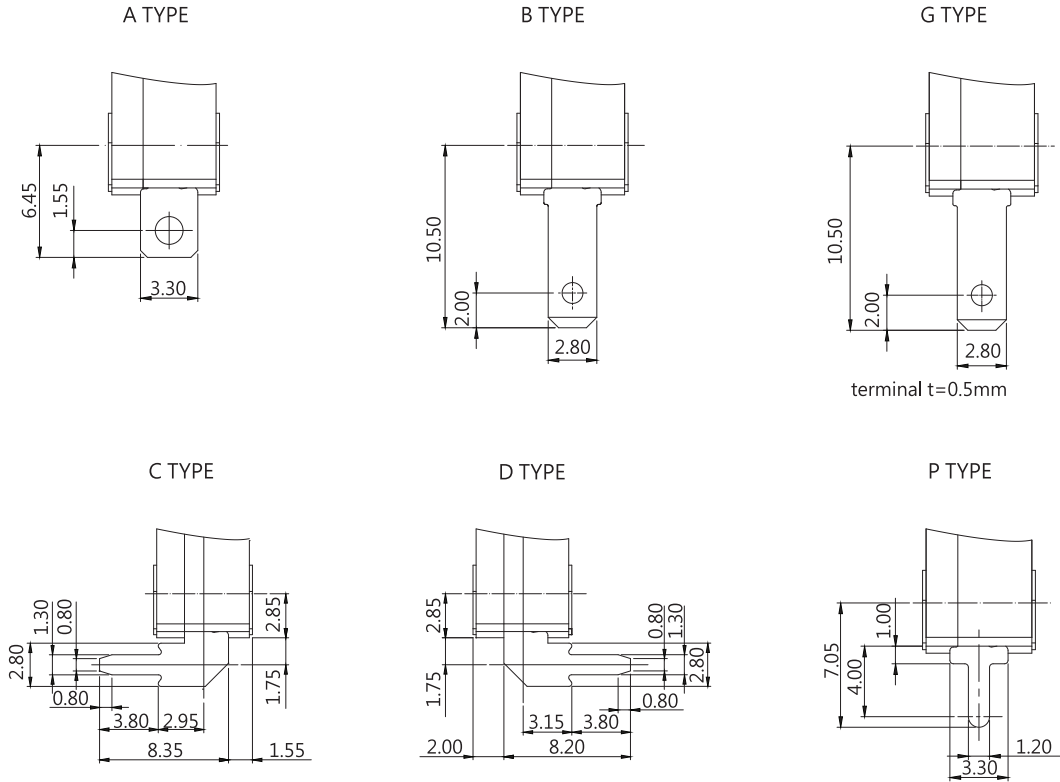

ORDERING INFORMATION

S M 1 — N 6     S — 0 0     5 0 0     A     0 — Z

SERIES PREFIX		RATING CURRENT		OPERATING FORCE		INTERNAL SNAP-FIT LEVER		OR		EXTERNAL SNAP-FIT LEVER		TERMINAL TYPE		CONTACT ARRANGEMENT		ROHS CODE	
C O D E		C O D E		C O D E		C O D E		C O D E		C O D E		C O D E		C O D E		C O D E	
G1	0.1A 125/250VAC	S	STANDARD	00		00		A		0	S.P.D.T	Z					
NC1	0.1A 30VDC	L	LIGHT	01		01		B		1	S.P.S.T NO						
N3	3A 125/250VAC	D	SLIGHT	02		02		C		2	S.P.S.T NC						
NC3	3A 30VDC	F	HEAVY	03		03		D									
GC3		H	HEAVIER	04		04		P									
N6	6A 125/250VAC			05		05		G									
G6	5A 30VDC			06		06											
				07		07											
				08		08											
				09		09											

NOTE		
ITEM	RATING CURRENT	OPERATING FORCE
1	CODE:G1	ALL
2	CODE:N3/G3	ALL
3	CODE:N6/G6	ALL
4	CODE:NC1/GC1	ALL
5	CODE:NC3/GC3	L,S,F,H

OPERATING CHARACTERISTICS (SM1 series - internal snap-fit lever)

SWITCH TYPE	PART SUFFIX	OF Max. (gf)		OP (mm)	PT Max. (mm)	OT Min. (mm)	MD Max. (mm)	FP Max. (mm)	RF Min. (gf)
		H	F						
SM1-□□□□-00□□-Z		H	355	11.4±0.3	1.1	0.4	0.2	12.2	100
		F	280						50
		S	150						25
		L	95						10
SM1-□□□□-01□□-Z		H	118	11.4±1.1	4.63	0.53	1.45	14.6	20
		F	90	11.8±0.8	3.6	0.6	0.8		9
		S	50						6
		L	28						1
SM1-□□□□-02□□-Z		H	107					11.4±1.3	5.29
		F	82	11.8±0.9	4.03	0.67	0.9	8	
		S	45					5	
		L	25					1	
SM1-□□□□-03□□-Z		H	87					11.0±1.8	7.47
		F	70	11.8±1.5	5.35	0.89	1.19	5	
		S	34					2	
		L	20					1	
SM1-□□□□-04□□-Z		H	111					13.3±1.2	5.02
		F	85	13.7±0.9	3.86	0.64	0.86	8	
		S	47					5	
		L	26					1	
SM1-□□□□-05□□-Z		H	117					17.1±1.1	4.60
		F	90	17.5±0.8	3.8	0.6	0.8	9	
		S	50					6	
		L	28					1	
SM1-□□□□-06□□-Z		H	97					18.0±1.5	6.12
		F	75	19.0±1.5	5.7	1.0	1.0	7	
		S	42					2	
		L	23					1	
SM1-□□□□-07□□-Z		H	55					9.9±2.7	11.20
		F	53	11.8±2.0	8.6	1.5	1.8	3	
		S	25					1	
		L	16					1	
SM1-□□□□-08□□-Z		F	58					-2.3±3.0	6.0
		S	25	1					
		L	17	1					
SM1-□□□□-09□□-Z		F	38	11.8±3.0	13.3	1.0	2.9	22.1	2
		S	15						2
		L	12						1

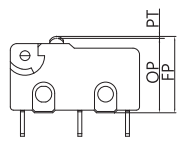
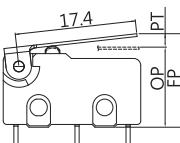
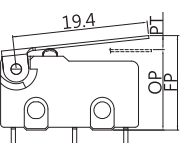
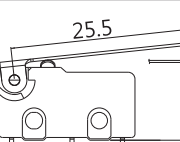
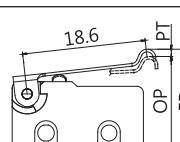
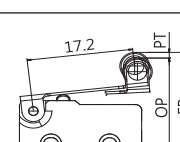
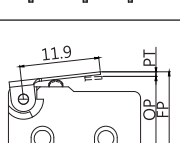
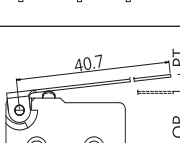
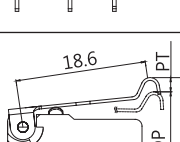
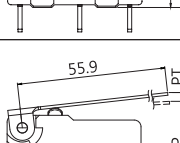

OPERATING CHARACTERISTICS (SM1 series - external snap-fit lever)

SWITCH TYPE	PART SUFFIX	OF Max. (gf)		OP (mm)	PT Max. (mm)	OT Min. (mm)	MD Max. (mm)	FP Max. (mm)	RF Min. (gf)
		H	F						
SM1- □□□ -500 □□ -Z		H	355	11.4±0.3	1.1	0.4	0.2	12.2	100
		F	280						50
		S	150						25
		L	95						10
SM1- □□□ -501 □□ -Z		H	145	11.8±1.10	4.6	0.9	0.8	15.3	15
		F	105						12
		S	50						6
		L	40						1
SM1- □□□ -502 □□ -Z		H	135	11.8±1.20	5.1	0.7	0.8	15.70	10
		F	100						8
		S	50						5
		L	40						--
SM1- □□□ -503 □□ -Z		H	110	11.8±1.60	6.90	0.9	1.10	17.10	10
		F	80						7
		S	45						4
		L	35						--
SM1- □□□ -504 □□ -Z		H	140	13.7±1.1	4.80	1.50	0.8	17.40	15
		F	100						11
		S	50						6
		L	40						1
SM1- □□□ -505 □□ -Z		H	145	17.9±1.0	4.05	0.55	0.9	21.00	15
		F	110						12
		S	55						6
		L	40						1
SM1- □□□ -506 □□ -Z		H	195	11.8±0.8	3.2	0.6	0.6	14.2	25
		F	145						19
		S	70						10
		L	50						2
SM1- □□□ -507 □□ -Z		H	85	11.8±2.6	10.8	1.2	1.9	20.0	5
		F	60						3
		S	35						1
		L	30						---
SM1- □□□ -508 □□ -Z		H	140	14.9±1.1	4.10	1.0	0.8	17.95	40
		F	100						11
		S	50						3
		L	40						1
SM1- □□□ -509 □□ -Z		H	65	11.8±3.5	14.8	2.8	2.6	23.1	1
		F	50						1
		S	30						1
		L	25						---

## CAUTIONS:

### 注意事項

1. To secure the switch, please use an M2.3 small screw on a flat surface and tighten with plane washers or spring washers to securely mount the switch, using a maximum torque of 0.26 N•m.  
若使用定位孔型式，請使用M2.3小型螺絲固定在平面上，並使用平墊圈或者彈性墊圈以便安全的鎖固開關，鎖固扭力請勿超過0.26 N•m.
2. To ensure the best performance of the switch, when handling/installing the switch, please do not apply uneven pressure to the direction indicated by the arrow in (Figure -1). Any uneven pressure or pressure direction other than the operating direction might be harmful or damage the switch performance.  
為確保開關正常運作，安裝及取用開關時，請勿直接施加壓力在(圖-1)中箭所指示的方向。如圖所示，任何不對稱的壓力或作動方向以外的壓力都不適在開關按柄上。
3. Do not exceed the end position (EP) and over travel (OT). This could cause operation failure.(Figure -2)  
圖示設計按壓位置，請勿超過開關下死點及超出行程，以避免開關失效。(圖-2)

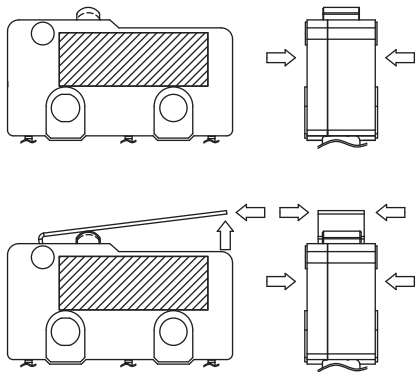

Figure-1

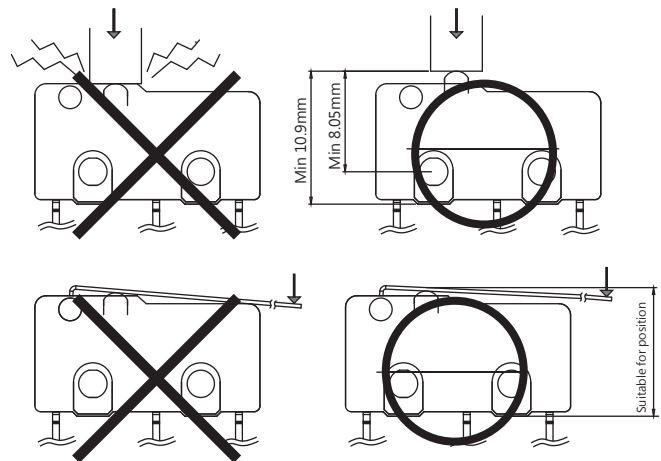

Figure-2

# MICRO SWITCHES



## SW2 SERIES

### SPECIFICATIONS

#### Contact Resistance (initial)

Max. 300mΩ

Measured by ohm meter - open voltage < 1VDC, driver current -100 mA

#### Insulation Resistance ( at 500VDC/minute )

Min. 100MΩ

#### Dielectric Strength

Min. 500VAC(50-60HZ)/minute between Live parts.

Min. 1500VAC(50-60HZ)/minute between Live parts and dead metal parts

#### Operating Temperature Range

-40°C to 125°C ( with no icing )

#### Vibration

10~55Hz, displacement 0.75 mm (p-p)

#### Electrical Service Life

Min. 10,000 operations

#### Electrical Operating Frequency

10~30 operations per minute

#### Mechanical Service Life

Min. 2,000,000 operations

#### Mechanical Operating Frequency

120 operations per minute

#### Operating application of the switch

Set the switch pushing distance from 60% to 90% of the specified OT value

### APPLICATIONS

Telephone, Air conditioner, Computer, Humidifier, Alarm, Time recorder, Mixer & Chopper, Solder gun, Neon phone, Fax machine, Joystick, Water pump, Gas detector, Pencil sharpener, Money sorter, Food processor, Electric knife, Toy car, Juice maker, Electric steak pan.

### CONTACT CONFIGURATION

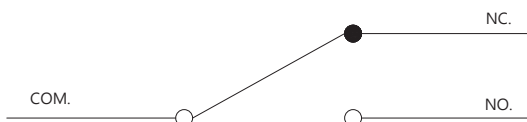

### DIMENSIONS

Unless otherwise specified, a tolerance of ±0.4mm applies to all dimensions.

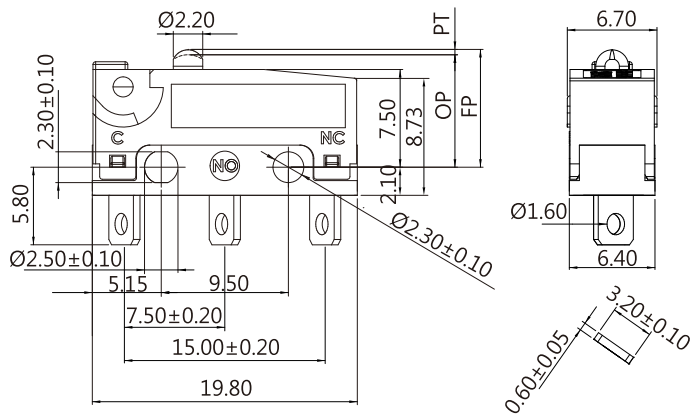

### MOUNTING HOLES

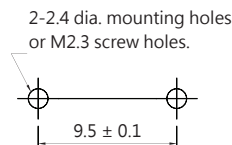

### MOUNTING HOLES FOR PCB TERMINAL

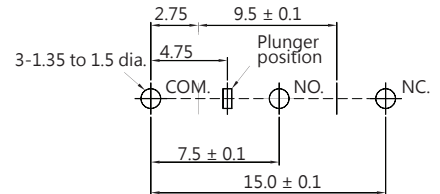

### CERTIFICATE INFORMATION

Model Name	UL · cUL	ENEC
SW2-C1	0.1RA 125/250VAC uT125 1E4	0.1A 125/250VAC uT125 1E4
SW2-C3	3GPA 125/250VAC uT125 1E4	3A 125/250VAC uT125 1E4
SW2-06	5RA 30VDC uT125 1E4	5A 30VDC uT125 1E4
	6GPA 125/250VAC uT125 1E4	6A 125/250VAC uT125 1E4
SW2-10	5RA 30VDC uT125 1E4	5A 30VDC uT125 1E4
	10RA125/250VAC uT125 1E4	10(2)A 125/250VAC uT125 1E4
	10GPA 125/250VAC uT125 1E4	
SW2-H10	5RA 30VDC uT125 1E4	5A 30VDC uT125 1E4
	10RA125/250VAC uT125 1E4	10(2)A 125/250VAC uT125 1E4
	10GPA 125/250VAC uT125 1E4	
	1/4HP 125/250VAC uT125 1E4	

### THE SELECTION OF RATING & FORCE

MODEL	Rating	L	S	H
SW2	0.1A	*	*	*
	3A	*	*	*
	6A	*	*	*
	10A 10(2)A		*	*
	1/4 hp 10A 10(2)A		*	*

NOTE : The Symbol " \* " to represent the result is accepted

TERMINAL TYPES ( THE thickness of each terminal is 0.6 mm )

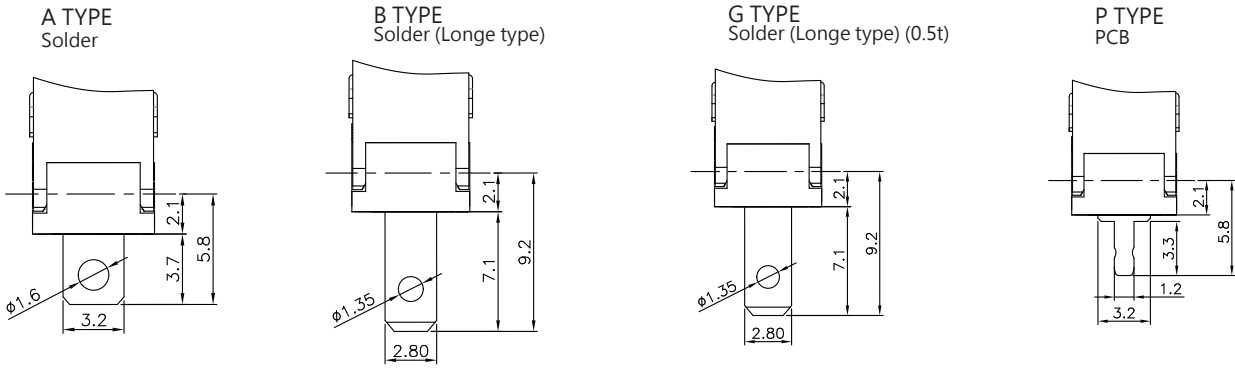

Terminal t=0.5mm

ORDERING INFORMATION

S	W	2	—	0	6	S	0	—	0	0	A	0	—	Z			
SERIES PREFIX				RATING CURRENT		OPERATING FORCE			COVER TYPE		ACTUATOR TYPE		TERMINAL TYPE		CIRCUIT ARRANGEMENT		ROHS CODE
				C1	0.1A 125/250 VAC	H	HEAVIER			00		A		0	S.P.D.T		
			C3	3A 125/250 VAC	S	STANDARD	01				B		1	S.P.S.T NO			
			06	6A 125/250 VAC	L	LIGHT	02		P		2	S.P.S.T NC					
			10	10A 125/250 VAC 10(2)A 125/250 VAC			03		G								
			H10	10A 125/250 VAC 10(2)A 125/250 VAC 1/4 hp 125/250 VAC			04										
							05										
							06										
							07										
							08										
							09										

#NOTE		
	RATING CURRENT	OPERATING FORCE
<b>1</b>	Code:C1	L, S, H
	Code:C3	L, S, H
	Code:06	L, S, H
	Code: 10	S, H
	Code:H10	S, H

OPERATING CHARACTERISTICS

SWITCH TYPE	PART SUFFIX	OF Max. (gf)		OP (mm)	PT Max. (mm)	OT Min. (mm)	MD Max. (mm)	FP Max. (mm)	RF Min. (gf)	
		H	S						H	S
SW2- □□□□ -00 □□ -Z		H	300	8.4 ± 0.3	1.2	0.4	0.2	9.9	H	70
		S	203						S	50
		L	150						L	30
SW2- □□□□ -01 □□ -Z		H	121	8.8 ± 1.1	4.3	0.6	0.6	1.2	H	17
		S	82						S	16
		L	73						L	14
SW2- □□□□ -02 □□ -Z		H	105	8.8 ± 1.2	4.8	0.67	0.7	12.4	H	14
		S	66						S	13
		L	55						L	11
SW2- □□□□ -03 □□ -Z		H	72	8.8 ± 1.6	6.3	0.89	0.9	13.5	H	12
		S	54						S	11
		L	29						L	6
SW2- □□□□ -04 □□ -Z		H	106	10.7 ± 1.2	4.6	0.64	0.75	14.3	H	15
		S	68						S	14
		L	42						L	7
SW2- □□□□ -05 □□ -Z		H	100	14.5 ± 1.1	4.3	0.6	0.6	17.7	H	16
		S	72						S	15
		L	54						L	4
SW2- □□□□ -06 □□ -Z		H	165	8.8 ± 0.9	3.2	1.0	0.5	11.1	H	23
		S	98						S	21
		L	66						L	10
SW2- □□□□ -07 □□ -Z		H	65	8.8 ± 2.6	10.1	1.5	2.3	16.3	H	8
		S	39						S	8
		L	33						L	1
SW2- □□□□ -08 □□ -Z		H	106	11.3 ± 1.3	4.9	0.6	0.8	14.9	H	14
		S	68						S	13
		L	42						L	6
SW2- □□□□ -09 □□ -Z		H	50	8.8 ± 3.5	13.8	1.0	3.6	19.1	H	7
		S	33						S	7
		L	23						L	1

## CAUTIONS:

### 注意事項

1. To secure the switch, please use an M2.3 small screw on a flat surface and tighten with plane washers or spring washers to securely mount the switch, using a maximum torque of 0.26 N•m.  
若使用定位孔型式，請使用M2.3小型螺絲固定在平面上，並使用平墊圈或者彈性墊圈以便安全的鎖固開關，鎖固扭力請勿超過0.26 N•m.
2. To ensure the best performance of the switch, when handling/installing the switch, please do not apply uneven pressure to the direction indicated by the arrow in (Figure -1). Any uneven pressure or pressure direction other than the operating direction might be harmful or damage the switch performance.  
為確保開關正常運作，安裝及取用開關時，請勿直接施加壓力在(圖-1)中箭所指示的方向。如圖所示，任何不對稱的壓力或作動方向以外的壓力都不適在開關按柄上。
3. Do not exceed the end position (EP) and over travel (OT). This could cause operation failure.  
圖示設計按壓位置，請勿超過開關下死點及超出行程，以避免開關失效。

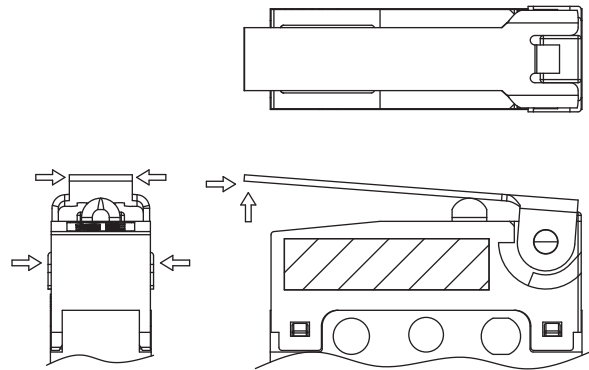

Figure-1

# MICRO SWITCHES



## DIMENSIONS

Unless otherwise specified, a tolerance of  $\pm 0.4\text{mm}$  applies to all dimensions.

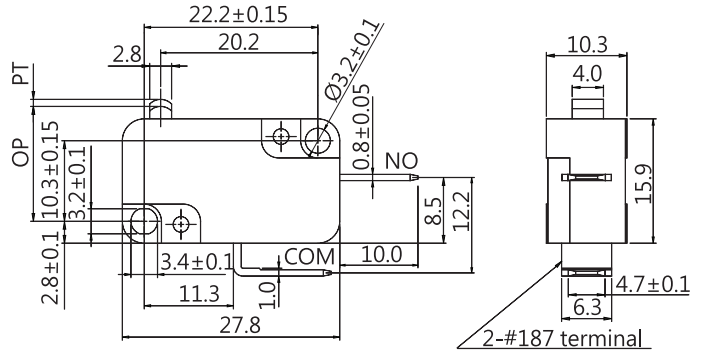

## V3 SERIES

( Full-Disconnection – Gap > 3mm )

### SPECIFICATIONS

#### Contact Resistance(initial)

Max. 30 m $\Omega$

Measured by ohm meter - open voltage < 1VDC, driver current -100 mA

#### Insulation Resistance (at 500 VDC / minute)

Min. 100 M $\Omega$

#### Dielectric Strength

Min. 1500VAC(50-60HZ)/minute between Live parts.

Min. 1500VAC(50-60HZ)/minute between Live parts and dead metal parts

#### Operating Temperature Range

-40°C to 125°C ( with no icing )

#### Vibration

10~55Hz, displacement 0.75 mm (p-p)

#### Electrical Service Life

All rating - Min. 10,000 operations

#### Electrical Operating Frequency

All rating 10~30 operations per minute

#### Mechanical Service Life

Min. 500,000 operations

#### Mechanical Operating Frequency

120 operations per minute

#### Operating application of the switch

Set the switch pushing distance from 60% to 90% of the specified OT value

### APPLICATIONS

Joystick, TV game, Time recorder, Air conditioner, Food processor, Juice maker, Alarm, Mixer, Shredder machine.

### THE SELECTION OF RATING & FORCE

MODEL	Rating	L K	S R	H G
V3	10A, 10(4) A	*	*	*
	16A, 16(4) A	*	*	*
	20.1 A	*	*	*
	25 A	*	*	*
	10.1(8)A	*	*	*

NOTE : The Symbol " \* " to represent the result is accepted

### CONTACT CONFIGURATION

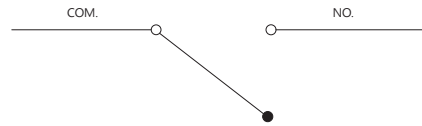

### MOUNTING HOLES

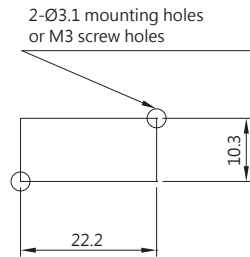

### CERTIFICATE INFORMATION

Model Name	UL, cUL	ENEC
V3-10	10.1A 125/250VAC 1/2 HP 125/250 VAC (Temp:100°C) Min. 6,000 operations	10(4)A 125/250VAC T100 1E4
V3-16	16A 125/250VAC 1/2 HP 125/250 VAC (Temp:125°C) Min. 6,000 operations	16(4)A 125/250VAC T125 1E4
V3-20	20.1A 125/250VAC 1 HP 125/250 VAC (Temp:100°C) Min. 6,000 operations	20.1A 125/250VAC T125 1E4 10.1(8)A 125/250VAC T125 1E4
V3-25	25A 125/250VAC 1 HP 125/250 VAC (Temp:100°C) Min. 6,000 operations	25.1A 125/250VAC T125 1E4 10.1(8)A 125/250VAC T125 1E4

TERMINAL TYPES

C TYPE

250 Series, Straight (0.8t)

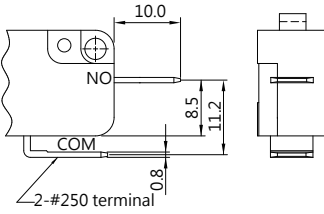

D TYPE

187 Series, Straight (0.8t)

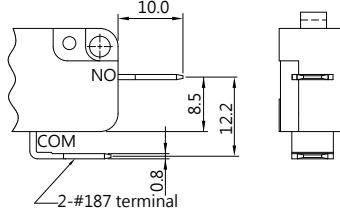

G TYPE

250 Series, PAST 5 Type (0.8t)

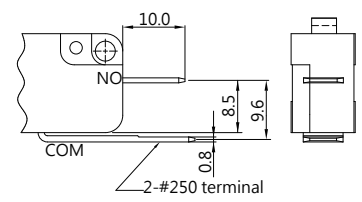

ORDERING INFORMATION

V	3	—	2	5	S	—	0	1	D	1	—	Z
SERIES PREFIX		RATING CURRENT		OPERATING FORCE		ACTUATOR TYPE		ACTUATOR TYPE		CIRCUIT ARRANGEMENT		ROHS CODE
			10	10.1A 125/250VAC	L		00		C	250 SERIES(C)	1	S.P.S.T. NO
			16	16A 125/250VAC	S		01		D	187 SERIES(D)		
			20	20.1A 125/250VAC	H		02		G	250 SERIES(G)		
			25	25A 125/250VAC	K		03					
					R		04					
					G		05					
							06					

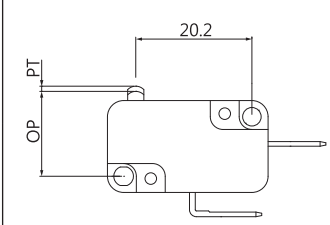
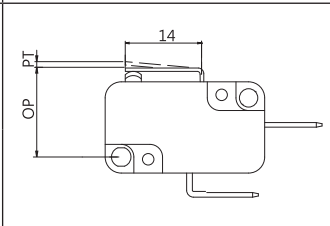
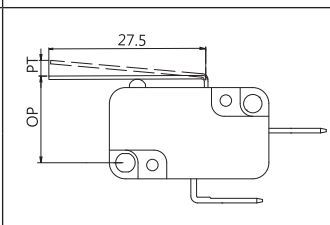
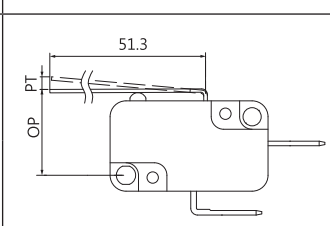
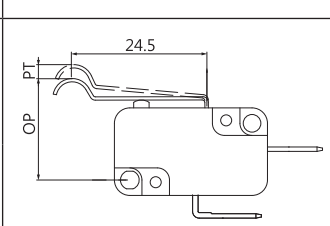
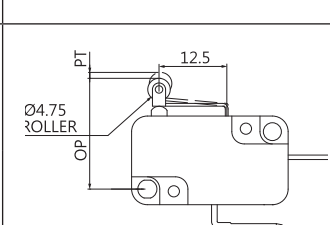
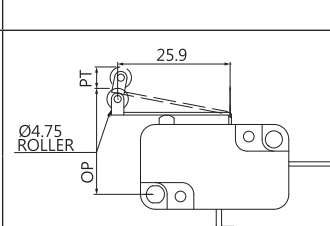

OPERATING CHARACTERISTICS

SWITCH TYPE	PART SUFFIX	OF Max. (gf)			OP (mm)	PT Max. (mm)	OT Min. (mm)	MD Max. (mm)
		L	S	H				
		K	R	G				
V3- □□□□ -00 □□ -Z		190	510	842	14.4± 0.5	1.90	0.70	1.20
		-	-	-	-	-	-	-
V3- □□□□ -01 □□ -Z		190	510	753	15.0± 0.8	2.40	0.50	1.40
		135	295	400	15.0± 1.2	4.10	0.90	1.70
V3- □□□□ -02 □□ -Z		100	260	374	15.0± 1.5	4.80	1.00	2.70
		80	150	200	15.0± 2.3	8.0	1.70	3.30
V3- □□□□ -03 □□ -Z		52	140	215	15.0± 2.8	8.9	1.80	5.10
		46	80	115	15.0± 4.7	15.0	3.10	7.00
V3- □□□□ -04 □□ -Z		108	290	439	18.4± 1.3	4.30	0.90	2.40
		88	170	235	18.4± 2.0	7.20	1.50	2.90
V3- □□□□ -05 □□ -Z		190	510	842	20.4± 0.7	2.20	0.40	1.20
		145	330	535	20.4± 1.0	3.70	0.80	1.50
V3- □□□□ -06 □□ -Z		102	275	395	20.4± 1.4	4.50	0.90	2.60
		84	160	220	20.4± 2.2	7.60	1.60	3.10

## CAUTIONS:

### 注意事項

1. To secure the switch, please use an M3 small screw on a flat surface and tighten with plane washers or spring washers to securely mount the switch, using a maximum torque of 0.59 N•m.  
若使用定位孔型式，請使用M3小型螺絲固定在平面上，並使用平墊圈或者彈性墊圈以便安全的鎖固開關，鎖固扭力請勿超過0.59 N•m.
2. To ensure the best performance of the switch, when handling/installing the switch, please do not apply uneven pressure to the direction indicated by the arrow in (Figure -1). Any uneven pressure or pressure direction other than the operating direction might be harmful or damage the switch performance.  
為確保開關正常運作，安裝及取用開關時，請勿直接施加壓力在(圖-1)中箭所指示的方向。如圖所示，任何不對稱的壓力或作動方向以外的壓力都不適在開關按柄上。

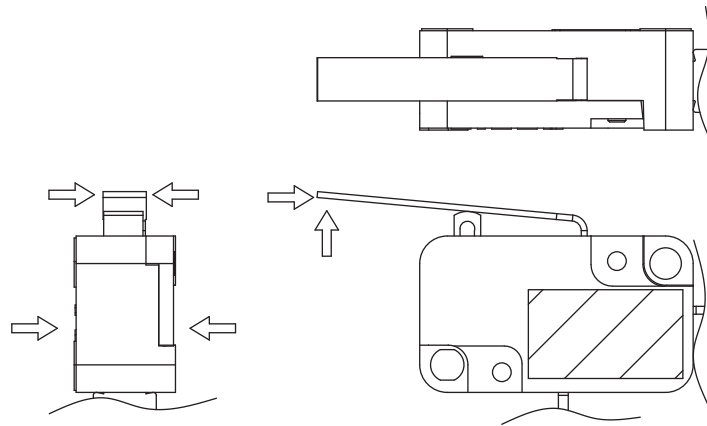

Figure-1

# MICRO SWITCHES



## V3 SERIES

( Micro-Disconnection-Gap < 3mm )

### SPECIFICATIONS

#### Contact Resistance(initial)

Max. 30 mΩ

Measured by ohm meter - open voltage < 1VDC, driver current -100 mA

#### Insulation Resistance (at 500 VDC / minute)

Min. 100 MΩ

#### Dielectric Strength

Min. 1000VAC(50-60HZ)/minute between Live parts.

Min. 1500VAC(50-60HZ)/minute between Live parts and dead metal parts

#### Operating Temperature Range

-40°C to 125°C ( with no icing )

#### Vibration

10~55Hz, displacement 0.75 mm (p-p)

#### Electrical Service Life

All rating - Min. 10,000 operations

#### Electrical Operating Frequency

All rating 10~30 operations per minute

#### Mechanical Service Life

Min. 5,000,000 operations

#### Mechanical Operating Frequency

120 operations per minute

#### Operating application of the switch

Set the switch pushing distance from 60% to 90% of the specified OT value

### APPLICATIONS

Joystick, TV game, Time Recorder, Air Conditioner, Food Processor, Juice Maker, Alarm, Mixer, Shredder Machine, Power Tool..

### DIMENSIONS

Unless otherwise specified, a tolerance of ±0.4mm applies to all dimensions.

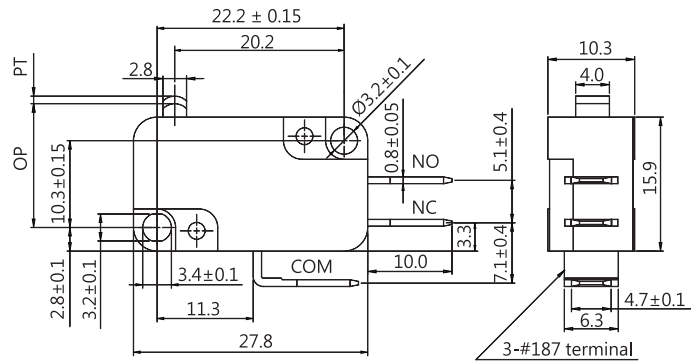

### CONTACT CONFIGURATION

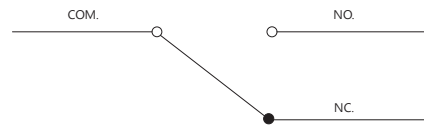

### MOUNTING HOLES

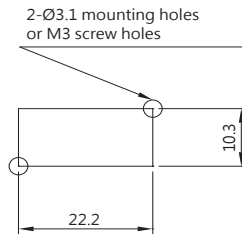

### CERTIFICATE INFORMATION

Model Name	UL · cUL	ENEC
V3-10	10.1A 125/250VAC 1/2 HP 125/250 VAC (Temp:100°C) Min. 6,000 operations	10(4)A 125/250VAC μT100 1E4
V3-16	16A 125/250VAC 1/2 HP 125/250 VAC (Temp:125°C) Min. 6,000 operations	16(4)A 125/250VAC μT125 1E4
V3-20	20.1A 125/250VAC 1 HP 125/250 VAC (Temp:100°C) Min. 6,000 operations	20.1A 125/250VACc μT125 1E4 10.1(8)A 125/250VAC μT125 1E4
V3-25	25A 125/250VAC 1 HP 125/250 VAC (Temp:100°C), Min. 6,000 operations	25.1A 125/250VAC μT125 1E4 10.1(8)A 125/250VAC μT125 1E4

### THE SELECTION OF RATING & FORCE

MODEL	Rating	L K	S R	H G
V3	10A, 10(4) A	*	*	*
	16A, 16(4) A	*	*	*
	20.1 A	*	*	*
	25 A	*	*	*
	10.1(8)A	*	*	*

NOTE : The Symbol " \* " to represent the result is accepted

TERMINAL TYPES

C TYPE

250 Series, Straight (0.8t)

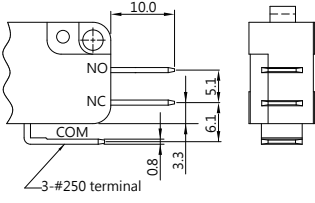

D TYPE

187 Series, Straight (0.8t)

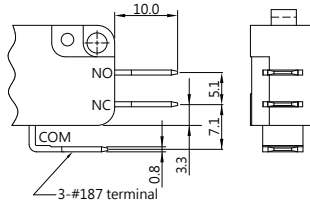

G TYPE

250 Series, PAST 5 Type (0.8t)

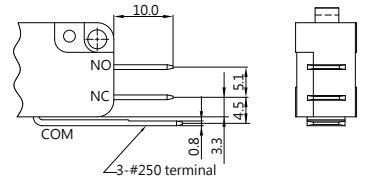

ORDERING INFORMATION

V	3	—	2	5	S	—	0	1	D	3	—	Z
SERIES PREFIX			RATING CURRENT		OPERATING FORCE		ACTUATOR TYPE		ACTUATOR TYPE	CIRCUIT ARRANGEMENT		ROHS CODE
			10 10.1A 125/250VAC		L 8.2		00		C 250 SERIES(C)	3 S.P.D.T.		
			16 16A 125/250VAC		S		01		D 187 SERIES(D)	4 S.P.S.T. NO		
			20 20.1A 125/250VAC		H		02		G 250 SERIES(G)	5 S.P.S.T. NC		
			25 25A 125/250VAC		K		03					
					R		04					
					G		05					
							06					

OPERATING CHARACTERISTICS

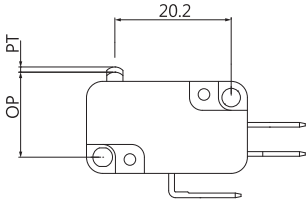
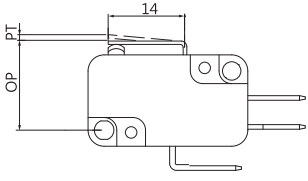
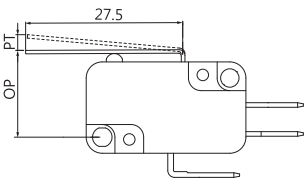
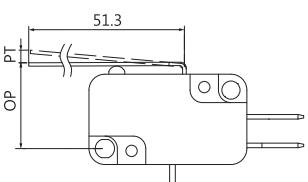
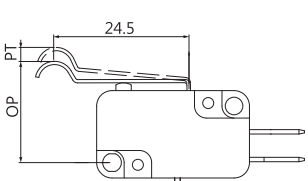
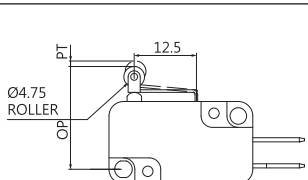
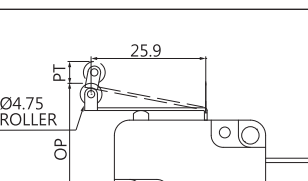
SWITCH TYPE	PART SUFFIX	OF Max. (gf)			OP (mm)	PT Max. (mm)	OT Min. (mm)	MD Max. (mm)
		L	S	H				
		K	R	G				
V3- □□□□ -00 □□ -Z		150	373	505	14.7±0.5	1.3	1.3	0.12
		-	-	-	-	-	-	-
V3- □□□□ -01 □□ -Z		145	316	435	15.4±0.8	2.0	0.70	0.2
		75	158	270	15.6±1.5	6.6	1.40	2.70
V3- □□□□ -02 □□ -Z		75	188	240	15.8±1.5	3.5	1.5	0.3
		45	82	130	16.6±2.3	6.0	3.0	0.6
V3- □□□□ -03 □□ -Z		40	98	135	16.0±2.82	7.5	4.0	1.0
		25	50	80	18.0±4.32	12.0	6.0	1.2
V3- □□□□ -04 □□ -Z		80	176	270	19.0±1.3	3.0	1.5	0.3
		50	115	145	19.9±2.0	5.5	3.5	0.5
V3- □□□□ -05 □□ -Z		160	358	505	20.7±0.7	1.5	1.0	0.15
		95	187	358	21.2±1.0	2.5	2.0	0.2
V3- □□□□ -06 □□ -Z		80	160	255	21.0±1.2	3.0	1.7	0.25
		50	87	140	21.9±2.2	5.0	4.5	0.35

## CAUTIONS:

### 注意事項

1. To secure the switch, please use an M3 small screw on a flat surface and tighten with plane washers or spring washers to securely mount the switch, using a maximum torque of 0.59 N•m.  
若使用定位孔型式，請使用M3小型螺絲固定在平面上，並使用平墊圈或者彈性墊圈以便安全的鎖固開關，鎖固扭力請勿超過0.59 N•m.
2. To ensure the best performance of the switch, when handling/installing the switch, please do not apply uneven pressure to the direction indicated by the arrow in (Figure -1). Any uneven pressure or pressure direction other than the operating direction might be harmful or damage the switch performance.  
為確保開關正常運作，安裝及取用開關時，請勿直接施加壓力在(圖-1)中箭所指示的方向。如圖所示，任何不對稱的壓力或作動方向以外的壓力都不適在開關按柄上。

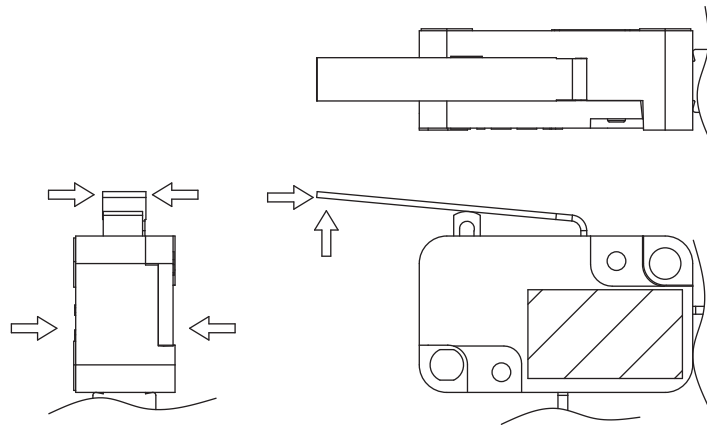

Figure-1

# MICRO SWITCHES



## V3 SERIES

( Full-Disconnection – Gap > 3mm )

### SPECIFICATIONS

#### Contact Resistance(initial)

Max. 30 mΩ

Measured by ohm meter - open voltage < 1VDC, driver current -100 mA

#### Insulation Resistance (at 500 VDC / minute)

Min. 100 MΩ

#### Dielectric Strength

Min. 1500VAC(50-60HZ)/minute between Live parts.

Min. 1500VAC(50-60HZ)/minute between Live parts and dead metal parts

#### Operating Temperature Range

-40°C to 125°C ( with no icing )

#### Vibration

10~55Hz, displacement 0.75 mm (p-p)

#### Electrical Service Life

All rating - Min. 10,000 operations

#### Electrical Operating Frequency

All rating 10~30 operations per minute

#### Mechanical Service Life

Min. 5,000,000 operations

#### Mechanical Operating Frequency

120 operations per minute

#### Operating application of the switch

Set the switch pushing distance from 60% to 90% of the specified OT value

### APPLICATIONS

Joystick, TV Game, Time Recorder, Air Conditioner, Food Processor, Juice Maker, Alarm, Mixer, Shredder Machine, Power Tool

### DIMENSIONS

Unless otherwise specified, a tolerance of ±0.4mm applies to all dimensions.

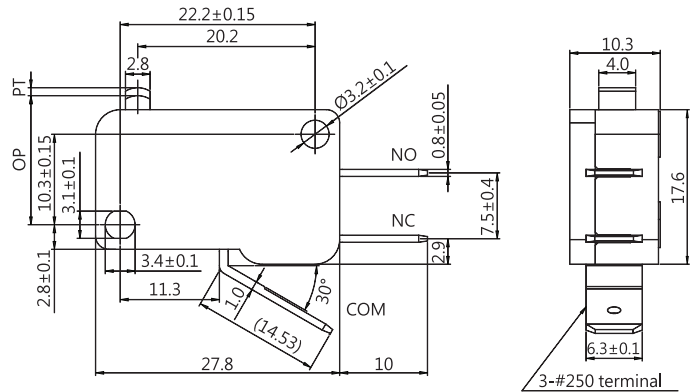

### CONTACT CONFIGURATION

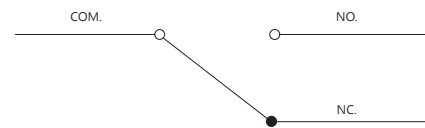

### MOUNTING HOLES

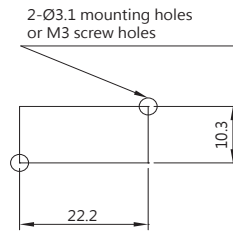

### CERTIFICATE INFORMATION

Model Name	UL, cUL	ENEC
V3-10	10RA 125/250 VAC T125 1E4	10(4)A 125/250VAC T125 1E4
V3-16	16RA 125/250 VAC T125 1E4	16(4)A 125/250VAC T125 1E4
V3-20	20RA 125/250 VAC T125 1E4	20.1A 125/250VAC T125 1E4 10.1(8)A 125/250VAC T125 1E4
V3-25	25.1RA 125/250 VAC T125 1E4	25.1A 125/250VAC T125 1E4 10.1(8)A 125/250VAC T125 1E4

### THE SELECTION OF RATING & FORCE

MODEL	Rating	L K	S R	H G
V3	10A, 10(4)A	*	*	*
	16A, 16(4)A	*	*	*
	20A, 20.1A	*	*	*
	25 A, 25.1A	*	*	*
	10.1(8)A	*	*	*

NOTE : The Symbol " \* " to represent the result is accepted

TERMINAL TYPES

K TYPE

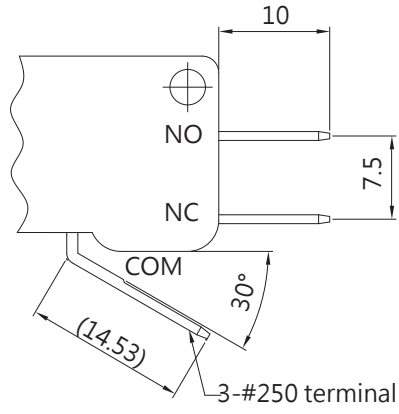

ORDERING INFORMATION

V	3
SERIES PREFIX	

1	0
RATING CURRENT	
10	10A 125/250VAC
16	16A 125/250VAC
20	20A 125/250VAC
25	25.1A 125/250VAC

H	
OPERATING FORCE	
L	
S	
H	
K	
R	
G	

0	1
ACTUATOR TYPE	
00	
01	
02	
03	
04	
05	
06	

K	
TERMINAL TYPE	
K	250 SERIES(K)

C	
CIRCUIT ARRANGEMENT	
C	S.P.D.T.
D	S.P.S.T. NO
E	S.P.S.T. NC

Z	
ROHS CODE	



OPERATING CHARACTERISTICS

SWITCH TYPE	PART SUFFIX	OF Max. (gf)			OP (mm)	PT Max. (mm)	OT Min. (mm)	MD Max. (mm)
		L	S	H				
		K	R	G				
V3- □□□□ -00 □□ -Z		190	510	842	14.4± 0.5	1.90	0.70	1.20
		-	-	-	-	-	-	-
V3- □□□□ -01 □□ -Z		190	510	753	15.0± 0.8	2.40	0.50	1.40
		135	295	400	15.0± 1.2	4.10	0.90	1.70
V3- □□□□ -02 □□ -Z		100	260	374	15.0± 1.5	4.80	1.00	2.70
		80	150	200	15.0± 2.3	8.0	1.70	3.30
V3- □□□□ -03 □□ -Z		52	140	215	15.0± 2.8	8.9	1.80	5.10
		46	80	115	15.0± 4.7	15.0	3.10	7.00
V3- □□□□ -04 □□ -Z		108	290	439	18.4± 1.3	4.30	0.90	2.40
		88	170	235	18.4± 2.0	7.20	1.50	2.90
V3- □□□□ -05 □□ -Z		190	510	842	20.4± 0.7	2.20	0.40	1.20
		145	330	535	20.4± 1.0	3.70	0.80	1.50
V3- □□□□ -06 □□ -Z		102	275	395	20.4± 1.4	4.50	0.90	2.60
		84	160	220	20.4± 2.2	7.60	1.60	3.10

## CAUTIONS:

### 注意事項

1. To secure the switch, please use an M3 small screw on a flat surface and tighten with plane washers or spring washers to securely mount the switch, using a maximum torque of 0.59 N•m.  
若使用定位孔型式，請使用M3小型螺絲固定在平面上，並使用平墊圈或者彈性墊圈以便安全的鎖固開關，鎖固扭力請勿超過0.59 N•m.
2. To ensure the best performance of the switch, when handling/installing the switch, please do not apply uneven pressure to the direction indicated by the arrow in (Figure -1). Any uneven pressure or pressure direction other than the operating direction might be harmful or damage the switch performance.  
為確保開關正常運作，安裝及取用開關時，請勿直接施加壓力在(圖-1)中箭所指示的方向。如圖所示，任何不對稱的壓力或作動方向以外的壓力都不適在開關按柄上。

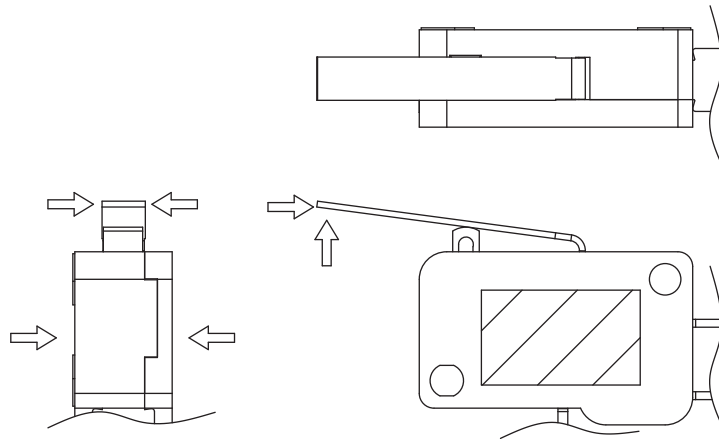

Figure-1

# MICRO SWITCHES



## DIMENSIONS

Unless otherwise specified, a tolerance of  $\pm 0.4\text{mm}$  applies to all dimensions.

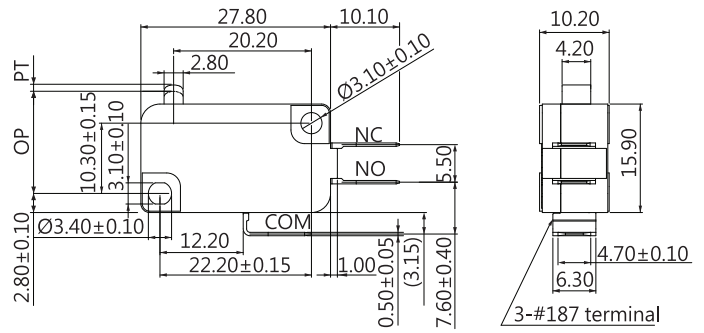

## VA1 SERIES

### SPECIFICATIONS

#### Contact Resistance(initial)

Max. 300 m $\Omega$

Measured by ohm meter - open voltage < 1VDC, driver current -100 mA

#### Insulation Resistance (at 500 VDC / minute)

Min. 100 M $\Omega$

#### Dielectric Strength

Min. 500VAC(50-60HZ)/minute between Live parts.

Min. 1500VAC(50-60HZ)/minute between Live parts and dead metal parts

#### Operating Temperature Range

-40°C to 125°C ( with no icing )

#### Vibration

10~55Hz, displacement 0.75 mm (p-p)

#### Electrical Service Life

0.1A - Min. 1,000,000 operations

others Rating - Min. 10,000 operations

#### Electrical Operating Frequency

10~30 operations per minute

#### Mechanical Service Life

Min. 10,000,000 operations

#### Mechanical Operating Frequency

120 operations per minute

#### Operating application of the switch

Set the switch pushing distance from 60% to 90% of the specified OT value

### MOUNTING HOLES

2-  $\varnothing 3.1$  mounting holes  
or M3 screw holes

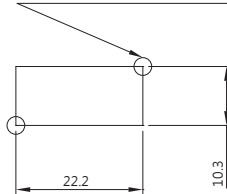

### CERTIFICATE INFORMATION

Model Name	UL, cUL	ENEC
VA1-P1	0.1RA 125/250VAC $\mu$ T85 5E4	0.1A 125/250VAC, $\mu$ 40T125 1E4
VA1-03	3RA 125/250VAC $\mu$ T85 5E4	3A 125/250VAC, $\mu$ 40T125 1E4
VA1-06	6RA 125/250VAC $\mu$ T85 5E4	6.1(2.5)A 125/250VAC, $\mu$ 40T125 1E4
VA1-10	10RA 125/250VAC $\mu$ T85 5E4	10(4)A 125/250VAC, $\mu$ 40T125 1E4
VA1-16	16RA 125/250VAC $\mu$ T85 5E4	16(4)A 125/250VAC, $\mu$ 40T125 1E4
VA1-20H	20RA 125/250VAC $\mu$ T85 2E4	20(4)A 125/250VAC, $\mu$ 40T125 1E4
VA1-26Q	Non	26A 125/250VAC, $\mu$ T85 1E4

### APPLICATIONS

Joystick, TV Game, Time Recorder, Air Conditioner, Food Processor, Juice Maker, Alarm, Mixer, Shredder Machine, Power Tool

### CONTACT CONFIGURATION

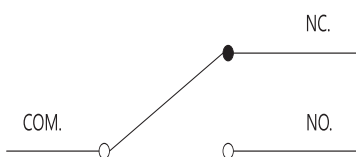

### THE SELECTION OF RATING & FORCE

MODEL	Rating	D	J	L	S	H	Q
VA1	0.1A	*	*	*	*	*	*
	3A	*	*	*	*	*	*
	6A	*	*	*	*	*	*
	6.1(2.5)A		*	*	*	*	*
	10A		*	*	*	*	*
	10(4)A		*	*	*	*	*
	16A		*	*	*	*	*
16(4)A					*	*	
20A						*	*
26A							*

NOTE : The Symbol " \* " to represent the result is accepted

TERMINAL TYPES

A TYPE  
Through-hole Soldering

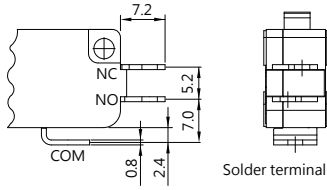

C TYPE  
250 Series (0.8t)

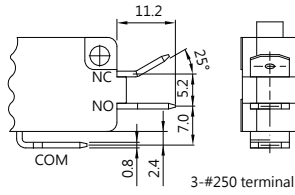

D TYPE  
187 Series, Straight (0.5t)

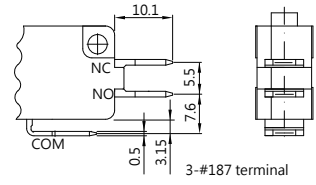

E TYPE  
250 Series, Dog-leg (0.8t)

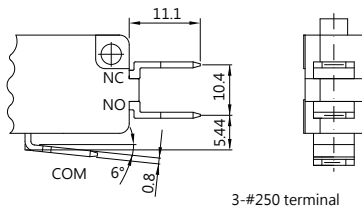

F TYPE  
250 Series, 90 degree (0.8t)

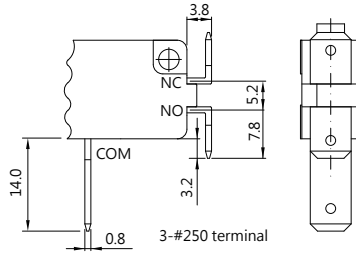

G TYPE  
250 Series, RAST 5 Type (0.8t)

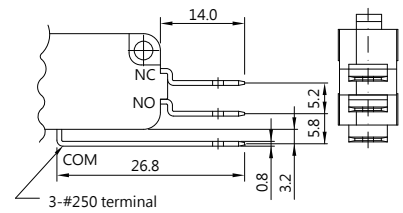

ORDERING INFORMATION

V	A	1	-	0	6	H	0	-	0	1	D	0	-	Z
SERIES PREFIX	C O D E	RATING CURRENT	C O D E	OPERATING FORCE	C O D E	ACTUATOR LEVER FIXED	C O D E	ACTUATOR TYPE	C O D E	TERMINAL TYPE	C O D E	CIRCUIT ARRANGEMENT	ROHS CODE	
	P1	0.1A 125/250VAC	Q	HEAVIER	0		00		C	250 SERIES (C)	0	S.P.D.T		
	03	3A 125/250VAC	H	HEAVY	1		01		D	187 SERIES (D)	1	S.P.S.T. NO		
	06	6A 125/250VAC 6.1(2.5)A 125/250VAC	S	STANDARD	2		02		E	250 SERIES (E)	2	S.P.S.T. NC		
	10	10A 125/250VAC 10(4)A 125/250VAC	L	LIGHT			03		F	250 SERIES (F)				
	16	16.1A 125/250VAC 16(4)A 125/250VAC	J	SLIGHT			04		G	250 SERIES (G)				
	20	20A 125/250VAC 20(4)A 125/250VAC	D	LIGHTNESS			05							
	26	26A 125/250VAC					06							

#NOTE		
	RATING CURRENT	OPERATING FORCE
1	Code:P1	Q,H,S,L,J,D
	Code:03	Q,H,S,L,J,D
	Code:06	Q,H,S,L,J,D
	Code:10	Q,H,S,L,J
	Code:16	Q,H,S,L,J
	Code:20	Q,H
	Code:26	Q

OPERATING CHARACTERISTICS

SWITCH TYPE	PART SUFFIX	OF Max. (gf)						OP (mm)	PT Max. (mm)	OT Min. (mm)	MD Max. (mm)
		D	J	L	S	H	Q				
VA1- □□□ 0-00D0-Z		50	100	150	200	300	350	14.7±0.5	1.9	1.0	0.4
VA1- □□□ 1-01D0-Z		60	110	150	190	290	340	15.3±0.5	2.8	1.0	0.5
VA1- □□□ 2-01D0-Z		40	60	90	120	160	190	15.3±1.1	5.2	0.6	0.9
VA1- □□□ 1-02D0-Z		35	55	90	110	160	185	15.3±1.1	5.9	1.2	1.0
VA1- □□□ 2-02D0-Z		20	35	50	65	95	110	15.3±2.1	9.7	3.4	2.2
VA1- □□□ 1-03D0-Z		20	35	50	65	95	110	15.3±2.4	9.3	-	2.1
VA1- □□□ 2-03D0-Z		15	25	35	40	60	75	15.3±4.1	16.2	-	3.5
VA1- □□□ 1-04D0-Z		35	65	90	120	175	205	18.7±1.3	5.5	1.9	1.1
VA1- □□□ 2-04D0-Z		20	40	55	70	100	120	18.7±2.0	8.7	3.2	1.7
VA1- □□□ 1-05D0-Z		60	110	170	220	310	375	20.7±0.6	2.7	1.1	0.45
VA1- □□□ 2-05D0-Z		35	65	95	120	180	210	20.7±1.0	4.65	0.8	0.8
VA1- □□□ 1-06D0-Z		30	60	120	125	165	200	20.45±1.6	3.8	1.6	1.25
VA1- □□□ 2-06D0-Z		20	35	55	65	100	115	20.45±2.1	9.3	3.3	1.8

\* There is another series of VA1 with MD reduced to 63%.

## CAUTIONS:

### 注意事項

1. To secure the switch, please use an M3 small screw on a flat surface and tighten with plane washers or spring washers to securely mount the switch, using a maximum torque of 0.59 N•m.

若使用定位孔型式，請使用M3小型螺絲固定在平面上，並使用平墊圈或者彈性墊圈以便安全的鎖固開關，鎖固扭力請勿超過0.59 N•m。

2. To ensure the best performance of the switch, when handling/installing the switch, please do not apply uneven pressure to the direction indicated by the arrow in (Figure -1). Any uneven pressure or pressure direction other than the operating direction might be harmful or damage the switch performance.

為確保開關正常運作，安裝及取用開關時，請勿直接施加壓力在(圖-1)中箭所指示的方向。如圖所示，任何不對稱的壓力或作動方向以外的壓力都不適在開關按柄上。

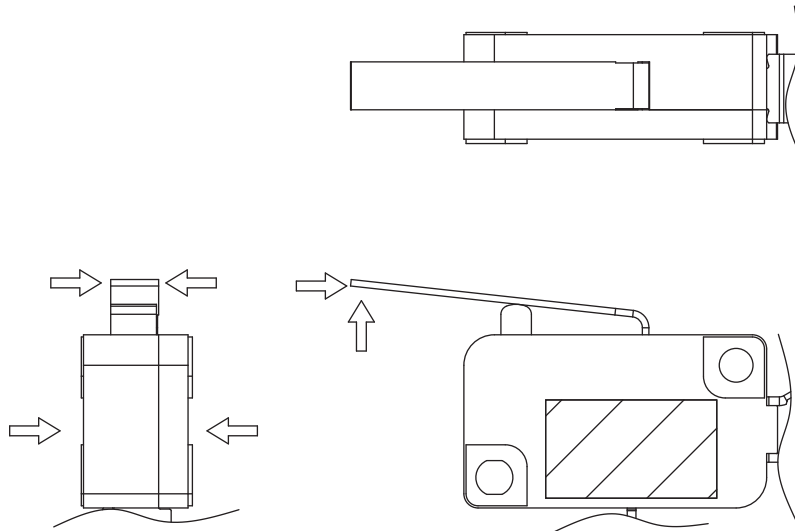

Figure-1

# MICRO SWITCHES



## VA2 SERIES

### SPECIFICATIONS

#### Contact Resistance(initial)

Max. 100 mΩ

Measured by ohm meter - open voltage < 1VDC, driver current -100 mA

#### Insulation Resistance (at 500 VDC / minute)

Min. 100 MΩ

#### Dielectric Strength

Min. 500VAC(50-60HZ)/minute between Live parts.

Min. 1500VAC(50-60HZ)/minute between Live parts and dead metal parts

#### Operating Temperature Range

-40°C to 125°C ( with no icing )

#### Vibration

10~55Hz, displacement 0.75 mm (p-p)

#### Electrical Service Life

Min. 10,000 operations

#### Electrical Operating Frequency

10~30 operations per minute

#### Mechanical Service Life

Min. 1,000,000 operations

#### Mechanical Operating Frequency

120 operations per minute

#### Operating application of the switch

Set the switch pushing distance from 60% to 90% of the specified OT value

### APPLICATIONS

Joystick, TV Game, Time Recorder, Air Conditioner, Food Processor, Juice Maker, Alarm, Mixer, Shredder Machine

### THE SELECTION OF RATING & FORCE

MODEL	Rating	B	D	N	L	S	H	Q
VA2	0.1A	*	*	*	*	*	*	*
	3A	*	*	*	*	*	*	*
	6A		*	*	*	*	*	*
	10A 10(4)A				*	*	*	*
	16A 16(4)A				*	*	*	*
	20A					*	*	*
	26A						*	*
6A T200						*	*	*

NOTE : The Symbol " \* " to represent the result is accepted

### DIMENSIONS

Unless otherwise specified, a tolerance of ±0.4mm applies to all dimensions.

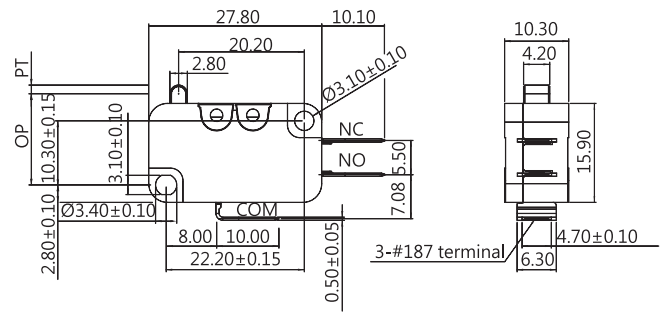

### CONTACT CONFIGURATION

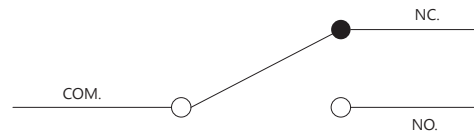

### MOUNTING HOLES

2-Ø3.1 mounting holes  
or M3 screw holes

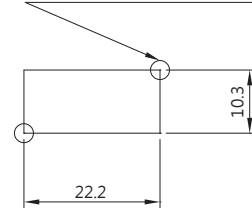

### CERTIFICATE INFORMATION

Model Name	UL · cUL	ENEC
VA2-P1	0.1RA 125/250VAC μT125 1E4	0.1A 125/250VAC μT125 1E4
VA2-03	3RA 125/250VAC μT125 1E4	3A 125/250VAC μT125 1E4
VA2-06	6RA 125/250VAC μT125 1E4	6A 125/250VAC μT125 1E4
VA2-10	10RA 125/250VAC μT125 1E4	10(4)A 125/250VAC μT125 1E4
VA2-16	16RA 16GPA 125/250VAC μT125 1E4 1/2HP 125/250VAC μT55 1E4	16(4)A125/250VAC μT125 1E4
VA2-20	20RA 125/250VAC μT125 1E4 1/2HP 125/250VAC μT55 1E4	20A 125/250VAC μT125 1E4
VA2-26	26RA 125/250VAC μT55 1E4	26A 125/250VAC μT55 1E4
VA2-A03	3GPA 125/250VAC μT85 1E4	3A 125/250VAC μT85 1E4
VA2-A06	6GPA 125/250VAC μT85 1E4	6A 125/250VAC μT85 1E4
VA2-T6	6RA 125/250VAC μT200 1E4	6A 125/250VAC μT200 1E4

TERMINAL TYPES

A TYPE

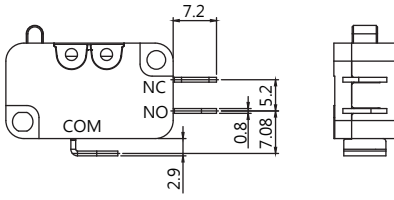

STANDARD

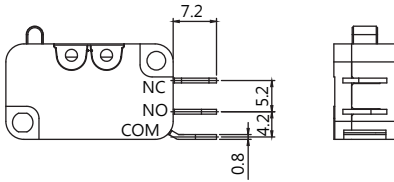

SIDE OUT

C TYPE  
250 terminal  
(6.3x0.8)

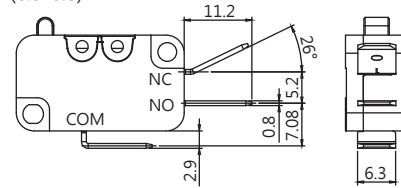

STANDARD

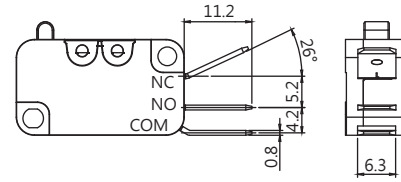

SIDE OUT

D TYPE  
187 terminal  
(4.7x0.5)

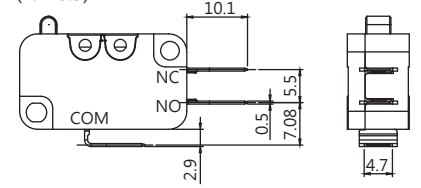

STANDARD

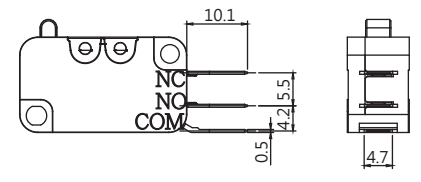

SIDE OUT

E TYPE  
250 terminal  
(6.3x0.8)

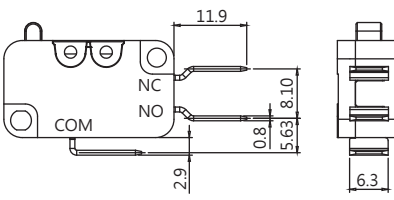

STANDARD

F TYPE  
250 terminal  
(6.3x0.8)

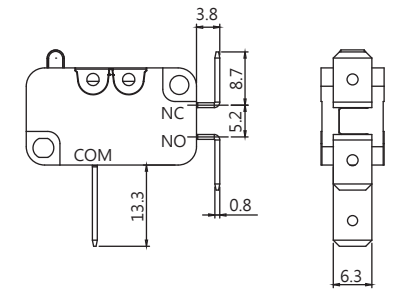

STANDARD

I TYPE  
187 terminal  
(4.7x0.8)

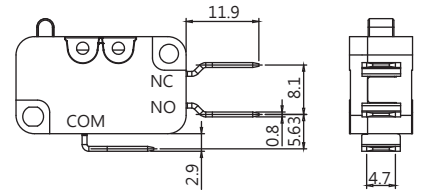

STANDARD

H TYPE  
187 terminal  
(4.7x0.8)

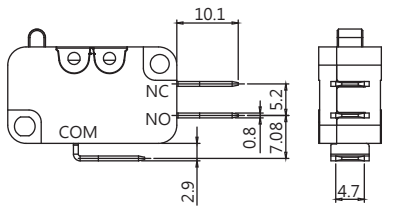

STANDARD

R TYPE  
250 terminal  
(6.3x0.8)

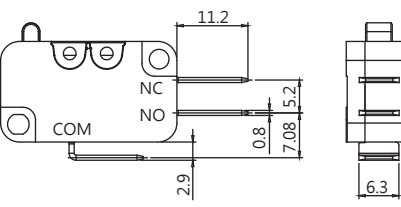

STANDARD

J TYPE  
250 terminal  
(6.0x0.8)

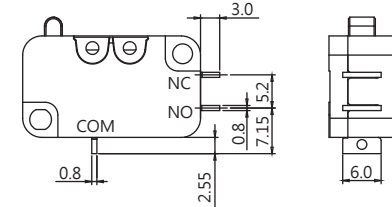

STANDARD

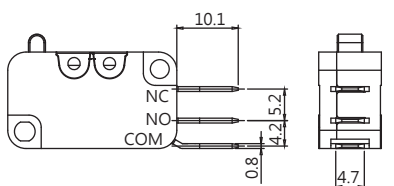

SIDE OUT

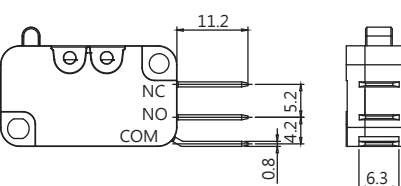

SIDE OUT



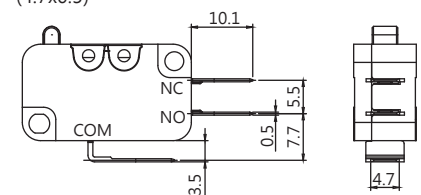







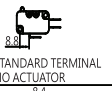
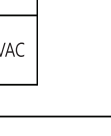
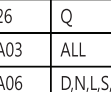
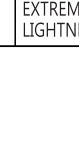





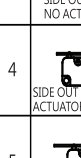





L TYPE  
187 terminal  
(4.7x0.5)



STANDARD



ORDERING INFORMATION

V	A	2	-	1	6	S	0		-	0	0	D		0	-	Z
SERIES PREFIX	CODE	RATING CURRENT	CODE	OPERATING FORCE	CODE	EXTERIOR TYPE	CODE	MOUNTING HOLES TYPE	CODE	ACTUATOR TYPE	CODE	TERMINAL TYPE	CODE	CIRCUIT ARRANGEMENT	ROHS CODE	
	P1	0.1A 125/250VAC T125	Q	HEAVIER	0	 STANDARD TERMINAL NO ACTUATOR		 MOUNTING HOLES Ø3.1	00	No Lever	A	 STANDARD		0	S.P.D.T	
	03	3A 125/250VAC T125	H	HEAVY	1	 STANDARD TERMINAL ACTUATOR AWAY BUTTON	A	 MOUNTING HOLES Ø2.9	01			 STANDARD	H	1	S.P.S.T NO	
	06	6A 125/250VAC T125	S	STANDARD	2	 STANDARD TERMINAL ACTUATOR NEAR BUTTON			02			 SIDE OUT		2	S.P.S.T NC	
	10	10A 10(4)A 125/250VAC T125	L	LIGHT	3	 SIDE OUT TERMINAL NO ACTUATOR			03		C	 STANDARD	I			
	16	16A 16(4)A 125/250VAC T125	N	SLIGHT	4	 SIDE OUT TERMINAL ACTUATOR AWAY BUTTON			04			 SIDE OUT	J			
	20	20A 125/250VAC T125	D	LIGHTNESS	5	 SIDE OUT TERMINAL ACTUATOR NEAR BUTTON						 STANDARD	L			
	26	26A 125/250VAC T55	B	EXTREMELY LIGHTNESS	6	 SIDE OUT TERMINAL ACTUATOR NEAR BUTTON						 SIDE OUT	R			
	A03	3A 125/250VAC T85			7	 SPECIAL TERMINAL NO ACTUATOR						 STANDARD				
	A06	6A 125/250VAC T85			8	 SPECIAL TERMINAL ACTUATOR AWAY BUTTON						 STANDARD				
	T6	6A 125/250VAC T200				 SPECIAL TERMINAL ACTUATOR NEAR BUTTON						 STANDARD				

# NOTE		
ITEM	RATING CURRENT	OPERATING FORCE
1	Code:P1	ALL
2	Code:03	ALL
3	Code:06	D,N,L,S,H,Q
4	Code:10	L,S,H,Q
5	Code:16	L,S,H,Q
6	Code:20	S,H,Q
7	Code:26	Q
8	Code:A03	ALL
9	Code:A06	D,N,L,S,H,Q
10	Code:T6	S,H,Q

OPERATING CHARACTERISTICS

SWITCH TYPE	PART SUFFIX	OF Max. (gf)							OP (mm)	PT Max. (mm)	OT Min. (mm)	MD Max. (mm)
		B	D	N	L	S	H	Q				
VA2- □□□ 0-00D0-Z		25	45	75	110	170	230	330	14.7±0.5	1.72	0.8	0.4
VA2- □□□ 1-01D0-Z		25	45	75	110	170	230	330	15.3±0.5	2.8	0.6	0.5
VA2- □□□ 2-01D0-Z		15	27	43	50	85	120	175	15.3±1.1	5.2	1.55	0.9
VA2- □□□ 1-02D0-Z		14	22	37	50	86	125	180	15.3±1.5	5.9	1.6	1.0
VA2- □□□ 2-02D0-Z		10	16	25	30	51	65	90	15.3±2.3	9.7	3.1	2.2
VA2- □□□ 1-03D0-Z		9	13	25	30	49	70	120	15.3±2.5	9.3	-	2.1
VA2- □□□ 2-03D0-Z		6	8	15	20	30	35	50	15.3±4.3	16.2	-	3.5
VA2- □□□ 1-04D0-Z		16	28	43	65	110	140	205	18.7±1.5	5.5	1.4	1.1
VA2- □□□ 2-04D0-Z		10	16	24	35	56	70	100	18.7±2.1	8.7	3.2	1.7
VA2- □□□ 1-05D0-Z		28	55	80	110	170	230	330	20.7±0.8	2.7	0.6	0.45
VA2- □□□ 2-05D0-Z		16	35	55	70	100	120	175	20.7±1.1	4.65	1.4	0.8
VA2- □□□ 1-06D0-Z		15	30	45	65	100	125	180	20.7±1.5	4.2	1.6	1.25
VA2- □□□ 2-06D0-Z		9	20	30	40	51	65	90	20.7±2.2	9.3	2.8	1.8

## CAUTIONS:

### 注意事項

1. To secure the switch, please use an M3 small screw on a flat surface and tighten with plane washers or spring washers to securely mount the switch, using a maximum torque of 0.59 N•m.  
若使用定位孔型式，請使用M3小型螺絲固定在平面上，並使用平墊圈或者彈性墊圈以便安全的鎖固開關，鎖固扭力請勿超過0.59 N•m.
2. To ensure the best performance of the switch, when handling/installing the switch, please do not apply uneven pressure to the direction indicated by the arrow in (Figure -1). Any uneven pressure or pressure direction other than the operating direction might be harmful or damage the switch performance.  
為確保開關正常運作，安裝及取用開關時，請勿直接施加壓力在(圖-1)中箭所指示的方向。如圖所示，任何不對稱的壓力或作動方向以外的壓力都不適在開關按柄上。

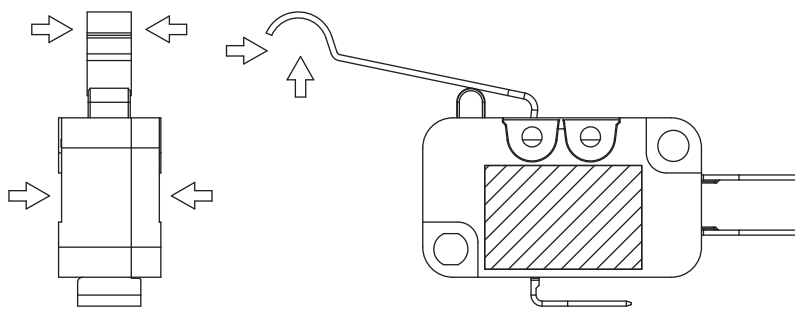
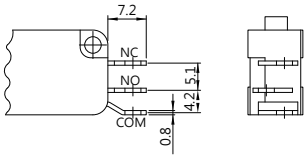

Figure-1



**TERMINAL TYPES**

**A TYPE**  
Through-hole Soldering



**C TYPE**  
250 Series (0.8t)

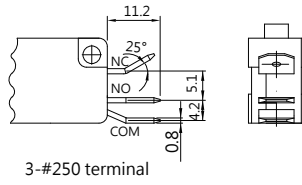

3-#250 terminal

**D TYPE**  
187 Series, Straight (0.5t)

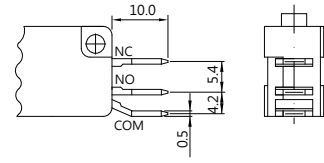

3-#187 terminal

**ORDERING INFORMATION**

V	K	P	1	H	0	3	D	0	Z				
SERIES PREFIX		CODE	CURRENT RATING	CODE	OPERATING FORCE		CODE	ACTUATOR TYPE	CODE	TERMINAL TYPE	CODE	CIRCUIT ARRANGEMENT	ROHS CODE
		P1	0.1A 125/250 VAC	B			00	No Lever	A	SOLDER TERMINAL	0	S.P.D.T	
		03	3A 125/250 VAC	D			01		C		250 SERIES	1	
		06	6A 125/250 VAC	N			02		D	187 SERIES		2	
		10	10A 125/250 VAC	L			03						
		15	15A 125/250 VAC	S			04						
				H									
				A									
				C									
				M									
				K									
				R									
				G									

#NOTE		
ITEM	RATING CURRENT	OPERATING FORCE
1	Code : P1	ALL
2	Code : 03	D, N, L, S, H, C, M, K, R, G,
3	Code : 06	N, L, S, H, M, K, R, G
4	Code : 10	L, S, H, K, R, G
5	Code : 15	S, H, R, G, SPECIFY H&G

OPERATING CHARACTERISTICS

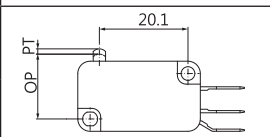
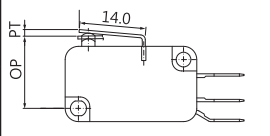
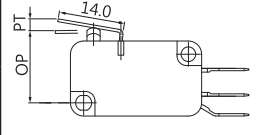
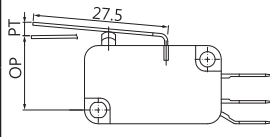
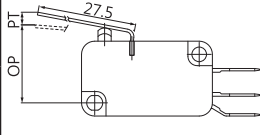
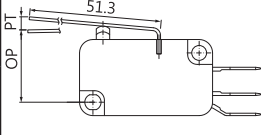
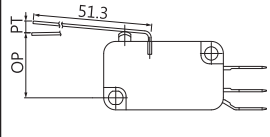
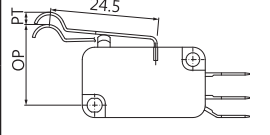
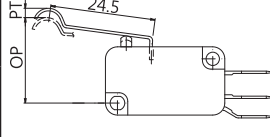
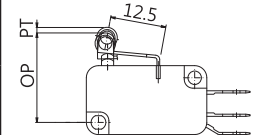
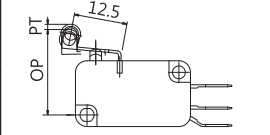
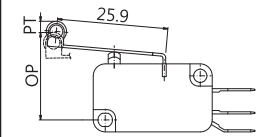
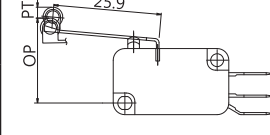
SWITCH TYPE	PART SUFFIX	OF Max. (gf)							OP (mm)	PT Max. (mm)	OT Min. (mm)	MD Max. (mm)
		B	D	N	L	S	H	SPECIFY H				
VK- □□□□ -00 □□ -Z		B	D	N	L	S	H	SPECIFY H	14.7±0.5	1.72	0.8	0.25
		18	45	75	110	170	230	330				
VK- □□□□ -01 □□ -Z		B	D	N	L	S	H	SPECIFY H	15.3±0.5	1.57	0.6	0.41
		18	45	75	110	170	230	330				
		A	C	M	K	R	G	SPECIFY G	15.3±1.1	2.85	1.55	0.5
		8	27	43	50	85	120	175				
VK- □□□□ -02 □□ -Z		B	D	N	L	S	H	SPECIFY H	15.3±1.5	3.18	1.60	0.76
		8	22	37	50	86	125	180				
		A	C	M	K	R	G	SPECIFY G	15.3±2.3	5.60	3.10	1.02
		5	16	22	30	51	65	90				
VK- □□□□ -03 □□ -Z		B	D	N	L	S	H	SPECIFY H	15.3±2.5	7.60	3.00	1.20
		6	13	25	30	49	70	120				
		A	C	M	K	R	G	SPECIFY G	15.3±4.3	10.0	5.00	1.70
		-	8	15	20	30	35	50				
VK- □□□□ -04 □□ -Z		B	D	N	L	S	H	SPECIFY H	18.7±1.5	3.18	1.40	0.76
		10	28	43	65	110	140	205				
		A	C	M	K	R	G	SPECIFY G	18.7±2.1	5.60	2.55	1.02
		7	16	24	35	56	70	100				
VK- □□□□ -05 □□ -Z		B	D	N	L	S	H	SPECIFY H	20.7±0.8	1.72	0.60	0.25
		20	55	80	110	170	230	330				
		A	C	M	K	R	G	SPECIFY G	20.7±1.1	2.50	1.40	0.40
		8	35	55	70	100	120	175				
VK- □□□□ -06 □□ -Z		B	D	N	L	S	H	SPECIFY H	20.7±1.5	3.18	1.60	0.76
		8	30	50	65	100	125	180				
		A	C	M	K	R	G	SPECIFY G	20.7±2.2	5.08	2.80	1.02
		7	20	30	40	51	65	90				

## CAUTIONS:

### 注意事項

1. To secure the switch, please use an M3 small screw on a flat surface and tighten with plane washers or spring washers to securely mount the switch, using a maximum torque of 0.59 N•m.

若使用定位孔型式，請使用M3小型螺絲固定在平面上，並使用平墊圈或者彈性墊圈以便安全的鎖固開關，鎖固扭力請勿超過0.59 N•m。

2. To ensure the best performance of the switch, when handling/installing the switch, please do not apply uneven pressure to the direction indicated by the arrow in (Figure -1). Any uneven pressure or pressure direction other than the operating direction might be harmful or damage the switch performance.

為確保開關正常運作，安裝及取用開關時，請勿直接施加壓力在(圖-1)中箭所指示的方向。如圖所示，任何不對稱的壓力或作動方向以外的壓力都不適在開關按柄上。

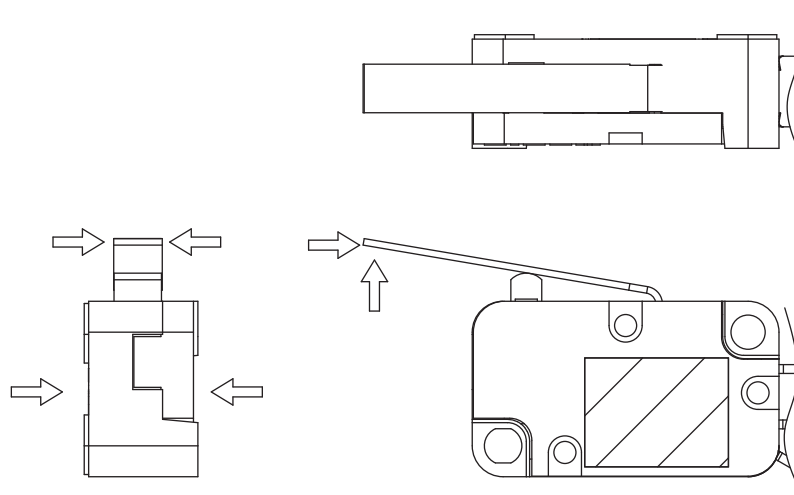

Figure-1

# MICRO SWITCHES



## VM SERIES

### SPECIFICATIONS

#### Contact Resistance(initial)

Max. 100 mΩ

Measured by ohm meter - open voltage < 1VDC, driver current -100 mA

#### Insulation Resistance (at 500 VDC / minute)

Min. 100 MΩ

#### Dielectric Strength

Min. 1000VAC(50-60HZ)/minute between Live parts.

Min. 1500VAC(50-60HZ)/minute between Live parts and dead metal parts

#### Operating Temperature Range

-40°C to 125°C ( with no icing )

#### Vibration

10~55Hz, displacement 0.75 mm (p-p)

#### Electrical Service Life

0.1A - Min. 1,000,000 operations

5A - Min. 10,000 operations

#### Electrical Operating Frequency

10~30 operations per minute

#### Mechanical Service Life

Min. 10,000,000 operations

#### Mechanical Operating Frequency

120 operations per minute

#### Operating application of the switch

Set the switch pushing distance from 60% to 90% of the specified OT value

### APPLICATIONS

Joystick, TV Game, Time Recorder, Gaming device, Air Conditioner, Food Processor, Juice Maker, Alarm, Mixer, Shredder Machine

### DIMENSIONS

Unless otherwise specified, a tolerance of ±0.4mm applies to all dimensions.

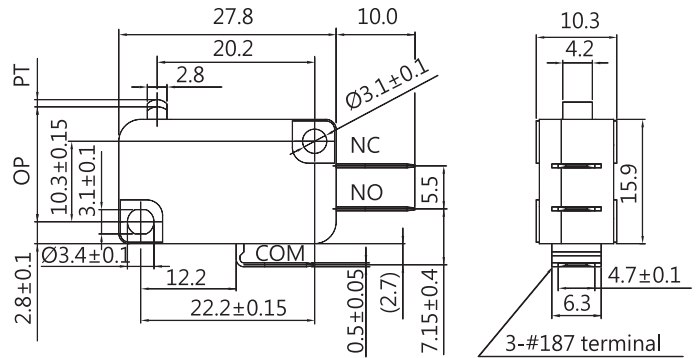

### CONTACT CONFIGURATION

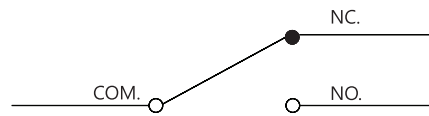

### MOUNTING HOLES

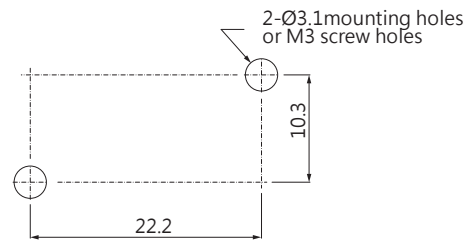

### CERTIFICATE INFORMATION

Model Name	UL, cUL
VM-05	5A 125/250 VAC (Temp:85°C) Min. 10,000 operations

### THE SELECTION OF RATING & FORCE

MODEL	Rating	B A	L K	D C	F E	S R	Q P	H G
VM	0.1A	*	*	*	*	*	*	*
	5A				*	*	*	*

NOTE : The Symbol " \* " to represent the result is accepted



**TERMINAL TYPES**

Solder terminal A TYPE

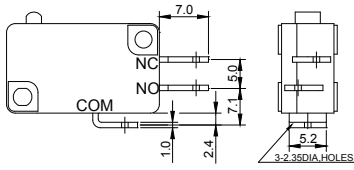

Screw terminal B TYPE

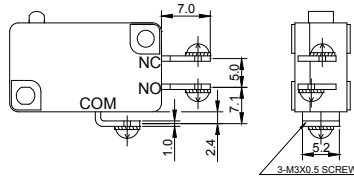

Terminal 250 Series C TYPE

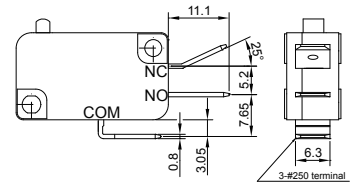

Terminal 187 Series D TYPE

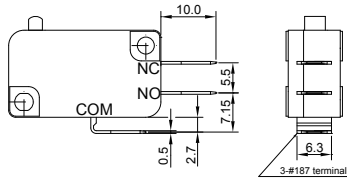

PCB terminal P TYPE

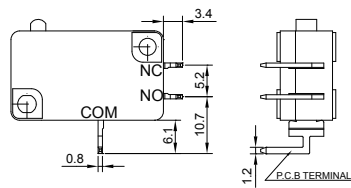

**ORDERING INFORMATION**

<b>V M</b>		<b>P 1</b>		<b>L</b>		<b>0 3</b>		<b>D</b>		<b>0</b>		<b>Z</b>
SERIES PREFIX		C O D E	RATING CURRENT	C O D E	OPERATING FORCE	C O D E	ACTUATOR TYPE	C O D E	TERMINAL TYPE	C O D E	CIRCUIT ARRANGEMENT	R O H S C O D E
		P1	0.1A 125/250 VAC	B L	 8.4	00	No Lever	A	 SOLDER TERMINAL	0	S.P.D.T	
		05	5A 125/250 VAC	D F S Q H A		 14.2	01		B	 SCREW TERMINAL	1	S.P.ST. NO
				K C E R P G		02		C	 250 SERIES	2	S.P.ST. NC	
						03		D	 187 SERIES			
						04		P	 PCB SERIES			

#NOTE		
ITEM	RATING CURRENT	OPERATING FORCE
1	Code : P1	ALL
2	Code : 05	F, S, Q, H, E, R, P, G

OPERATING CHARACTERISTICS

SWITCH TYPE	PART SUFFIX	OF Max. (gf)							OP (mm)	PT Max. (mm)	OT Min. (mm)	MD Max. (mm)
		B	L	D	F	S	Q	H				
VM- □□□ -00 □□ -Z		B	L	D	F	S	Q	H	14.7±0.5	1.3	0.8	0.4
	20	50	100	150	200	330	400					
VM- □□□ -01 □□ -Z		B	L	D	F	S	Q	H	15.3±0.5	1.6	0.6	0.5
	20	50	100	150	200	330	400					
		A	K	C	E	R	P	G	15.3±1.1	2.80	1.75	0.75
	13	28	54	77	120	151	200					
VM- □□□ -02 □□ -Z		B	L	D	F	S	Q	H	15.3±1.5	3.3	1.6	1.2
	9	30	44	66	120	160	220					
		A	K	C	E	R	P	G	15.3±2.3	5.75	3.1	1.6
	5	17	22	41	51	95	115					
VM- □□□ -03 □□ -Z		B	L	D	F	S	Q	H	15.3±2.5	7.6	3.0	2.2
	5	15	24	35	60	100	120					
		A	K	C	E	R	P	G	15.3±4.3	11.1	5.0	3.0
	-	8	20	21	38	60	75					
VM- □□□ -04 □□ -Z		B	L	D	F	S	Q	H	18.7±1.5	3.4	1.6	1.2
	10	30	60	74	120	180	220					
		A	K	C	E	R	P	G	18.7±2.1	5.3	2.55	1.4
	10	19	34	46	57	100	125					
VM- □□□ -05 □□ -Z		B	L	D	F	S	Q	H	20.7±0.8	1.5	0.6	0.5
	20	50	97	145	200	320	400					
		A	K	C	E	R	P	G	20.7±1.1	2.9	1.4	0.7
	14	31	59	85	115	180	220					
VM- □□□ -06 □□ -Z		B	L	D	F	S	Q	H	20.7±1.5	3.4	1.6	1.2
	10	30	47	70	120	170	220					
		A	K	C	E	R	P	G	20.7±2.2	5.5	2.8	1.5
	9	18	24	46	47	100	120					

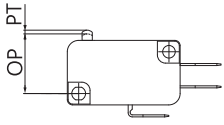
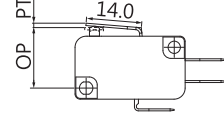
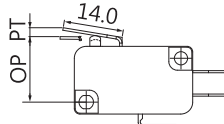
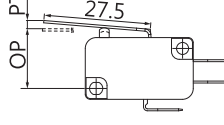
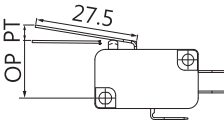
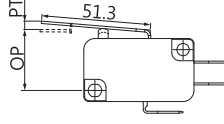
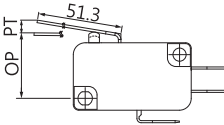
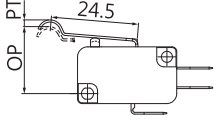
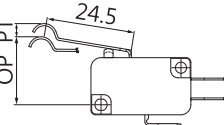
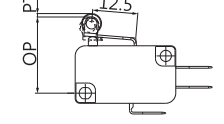
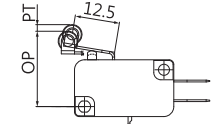
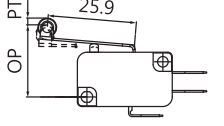
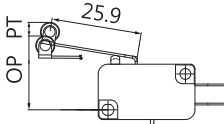
## CAUTIONS:

### 注意事項

1. To secure the switch, please use an M3 small screw on a flat surface and tighten with plane washers or spring washers to securely mount the switch, using a maximum torque of 0.59 N•m.  
若使用定位孔型式，請使用M3小型螺絲固定在平面上，並使用平墊圈或者彈性墊圈以便安全的鎖固開關，鎖固扭力請勿超過0.59 N•m.
2. To ensure the best performance of the switch, when handling/installing the switch, please do not apply uneven pressure to the direction indicated by the arrow in (Figure -1). Any uneven pressure or pressure direction other than the operating direction might be harmful or damage the switch performance.  
為確保開關正常運作，安裝及取用開關時，請勿直接施加壓力在(圖-1)中箭所指示的方向。如圖所示，任何不對稱的壓力或作動方向以外的壓力都不適在開關按柄上。

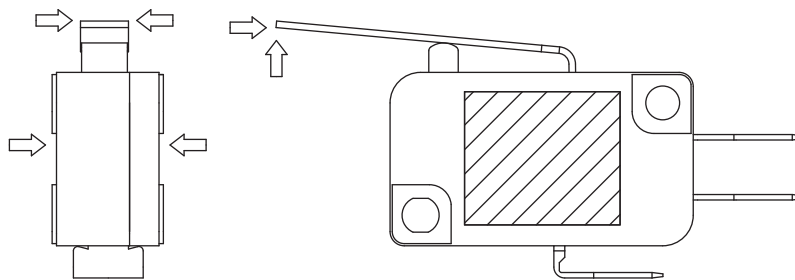

Figure-1

# MICRO SWITCHES



## DIMENSIONS

Unless otherwise specified, a tolerance of  $\pm 0.4\text{mm}$  applies to all dimensions.

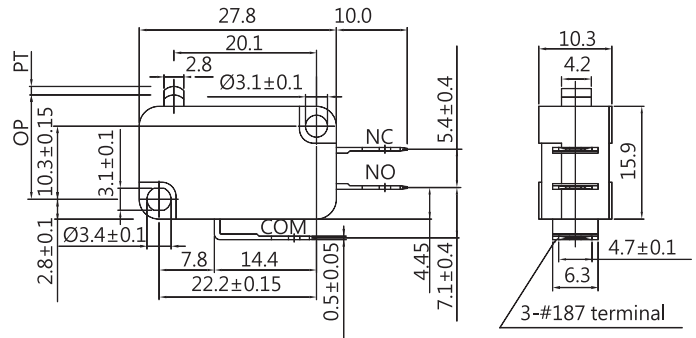

## VMN SERIES

### SPECIFICATIONS

#### Contact Resistance(initial)

Max. 100 m $\Omega$

Measured by ohm meter - open voltage < 1VDC, driver current -100 mA

#### Insulation Resistance (at 500 VDC / minute)

Min. 100 M $\Omega$

#### Dielectric Strength

Min. 1000VAC(50-60HZ)/minute between Live parts.

Min. 1500VAC(50-60HZ)/minute between Live parts and dead metal parts

#### Operating Temperature Range

-40°C to 125°C ( with no icing )

#### Vibration

10~55Hz, displacement 0.75 mm (p-p)

#### Electrical Service Life

0.1A - Min. 1,000,000 operations

Other ratings - Min. 10,000 operations

#### Electrical Operating Frequency

10~30 operations per minute

#### Mechanical Service Life

Min. 10,000,000 operations

#### Mechanical Operating Frequency

120 operations per minute

#### Operating application of the switch

Set the switch pushing distance from 60% to 90% of the specified OT value

### APPLICATIONS

Joystick, TV game, Time Recorder, Air Conditioner, Food Processor, Juice Maker, Alarm, Mixer, Shredder Machine.

### CONTACT CONFIGURATION

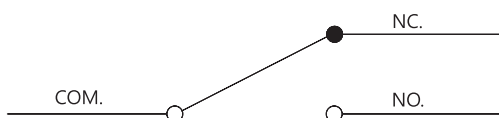

### MOUNTING HOLES

2- $\varnothing 3.1$  mounting holes  
or M3 screw holes

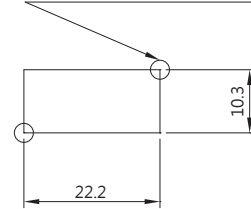

### CERTIFICATE INFORMATION

Model Name	UL、cUL	ENEC
VMN-P1	0.1A 30VDC (Temp:120°C) 0.1A 125/250 VAC (Temp:120°C) Min. 6,000 operations	0.1A 125/250VAC $\mu 40T125 1E4$
VMN-03	3A 125/250 VAC (Temp:120°C) Min. 6,000 operations	3A 125/250VAC $\mu 40T125 1E4$
VMN-06	6A 125/250 VAC (Temp:120°C) Min. 6,000 operations	6A 125/250VAC $\mu 40T125 1E4$
VMN-T6S	6A 125/250 VAC (Temp:200°C) Min. 6,000 operations	Non
VMN-10	10A 125/250 VAC (Temp:120°C) Min. 6,000 operations	10A 125/250VAC $\mu 40T125 1E4$
VMN-15	15A 1/2HP 125/250 VAC (Temp:120°C) Min. 6,000 operations	15A 16(4)A 125/250VAC $\mu 40T125 1E4$

### THE SELECTION OF RATING & FORCE

MODEL	Rating	B A	D C	N M	L K	S R	H G	SPECIFY H & G
VMN	0.1A	*	*	*	*	*	*	*
	3A		*	*	*	*	*	*
	6A			*	*	*	*	*
	10A				*	*	*	*
	15A					*	*	*
	16(4)A							*

NOTE : The Symbol " \* " to represent the result is accepted

## TERMINAL TYPES

**A TYPE**  
Through-hole Soldering

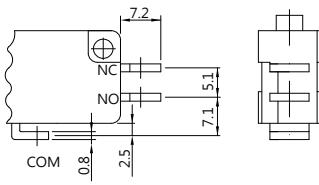

**B TYPE**  
Screw

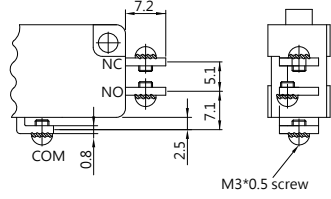

**C TYPE**  
250 Series (0.8t)

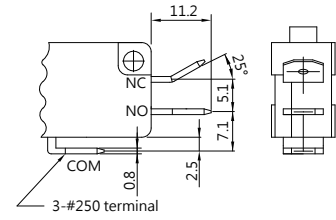

**D TYPE**  
187 Series, Straight (0.8t)

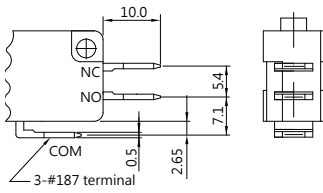

**E TYPE**  
250 Series, Dog-leg (0.8t)

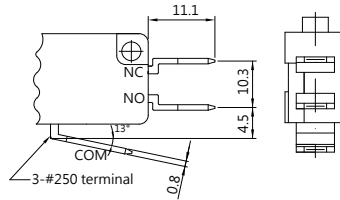

**F TYPE**  
250 Series, 90 degree (0.8t)

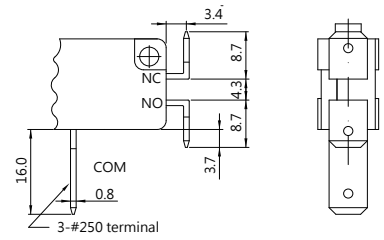

**G TYPE**  
250 Series, RAST 5 Type (0.8t)

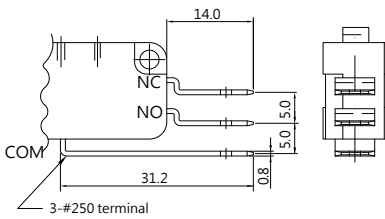

**K TYPE**  
PCB terminal, 250 Series (0.8t)

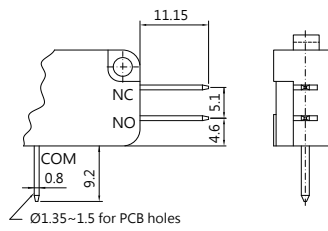

**P TYPE**  
PCB

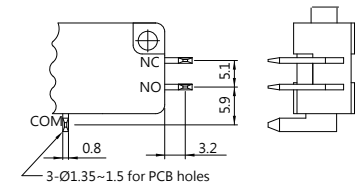

## ORDERING INFORMATION

V	M	N	-	P	1	H	-	0	3	D	0	-	B	-	Z						
SERIES PREFIX			CODE	RATING CURRENT		CODE	OPERATING FORCE		CODE	ACTUATOR TYPE		CODE	TERMINAL TYPE		CODE	CIRCUIT ARRANGEMENT		CODE	COLOR		ROHS CODE
			P1	0.1A 125/250 VAC		B			00	No Lever		A			0	S.P.D.T		B	BLACK		
			03	3A 125/250 VAC		D			01			B					1	S.P.ST. NO			
			06	6A 125/250 VAC		N			02			C	250 SERIES				2	S.P.ST. NC			
			10	10A 125/250 VAC		S			03			D	187 SERIES								
			15	15A 125/250 VAC 16(4) 125/250 VAC		H			04			E	250 SERIES								
						A						F	250 SERIES								
						C				P	PCB TERMINAL										
						M				G	250 SERIES										
						K				K	PCB SERIES										
						R															
						G															

#NOTE		
ITEM	RATING CURRENT	OPERATING FORCE
1	0.1A	ALL
2	3A	D, N, L, S, H, C, M, K, R, G, SPECIFY H&G
3	6A	N, L, S, H, M, K, R, G, SPECIFY H&G
4	10A	L, S, H, K, R, G, SPECIFY H&G
5	15A	S, H, R, G, SPECIFY H&G
6	16(4)A	SPECIFY H&G

OPERATING CHARACTERISTICS

SWITCH TYPE	PART SUFFIX	OF Max. (gf)							OP (mm)	PT Max. (mm)	OT Min. (mm)	MD Max. (mm)
		B	D	N	L	S	H	SPECIFY H				
VMN- □□□ -00 □□ -B-Z		18	45	75	110	170	230	330	14.7±0.5	1.72	0.8	0.25
	B	D	N	L	S	H	SPECIFY H					
VMN- □□□ -01 □□ -B-Z		18	45	75	110	170	230	330	15.3±0.5	1.57	0.6	0.41
	B	D	N	L	S	H	SPECIFY H					
		8	27	43	50	85	120	175	15.3±1.1	2.85	1.55	0.5
	A	C	M	K	R	G	SPECIFY G					
VMN- □□□ -02 □□ -B-Z		8	22	37	50	86	125	180	15.3±1.5	3.18	1.60	0.76
	B	D	N	L	S	H	SPECIFY H					
		5	16	22	30	51	65	90	15.3±2.3	5.60	3.10	1.02
	A	C	M	K	R	G	SPECIFY G					
VMN- □□□ -03 □□ -B-Z		6	13	25	30	49	70	120	15.3±2.5	7.60	3.00	1.2
	B	D	N	L	S	H	SPECIFY H					
		6	8	15	20	30	35	50	15.3±4.3	10.0	5.00	1.70
	A	C	M	K	R	G	SPECIFY G					
VMN- □□□ -04 □□ -B-Z		10	28	43	65	110	140	205	18.7±1.5	3.18	1.40	0.76
	B	D	N	L	S	H	SPECIFY H					
		7	16	24	35	56	70	100	18.7±2.1	5.60	2.55	1.02
	A	C	M	K	R	G	SPECIFY G					
VMN- □□□ -05 □□ -B-Z		20	55	80	110	170	230	330	20.7±0.8	1.72	0.60	0.25
	B	D	N	L	S	H	SPECIFY H					
		8	35	55	70	100	120	175	20.7±1.1	2.50	1.40	0.40
	A	C	M	K	R	G	SPECIFY G					
VMN- □□□ -06 □□ -B-Z		8	30	50	65	100	125	180	20.7±1.5	3.18	1.60	0.76
	B	D	N	L	S	H	SPECIFY H					
		7	20	30	40	51	65	90	20.7±2.2	5.08	2.80	1.02
	A	C	M	K	R	G	SPECIFY G					

## CAUTIONS:

### 注意事項

1. To secure the switch, please use an M3 small screw on a flat surface and tighten with plane washers or spring washers to securely mount the switch, using a maximum torque of 0.59 N•m.  
若使用定位孔型式，請使用M3小型螺絲固定在平面上，並使用平墊圈或者彈性墊圈以便安全的鎖固開關，鎖固扭力請勿超過0.59 N•m.
2. To ensure the best performance of the switch, when handling/installing the switch, please do not apply uneven pressure to the direction indicated by the arrow in (Figure -1). Any uneven pressure or pressure direction other than the operating direction might be harmful or damage the switch performance.  
為確保開關正常運作，安裝及取用開關時，請勿直接施加壓力在(圖-1)中箭所指示的方向。如圖所示，任何不對稱的壓力或作動方向以外的壓力都不適在開關按柄上。

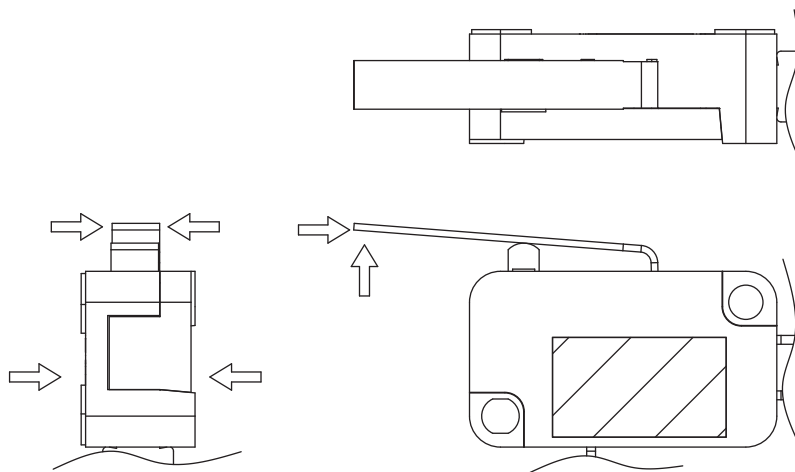

Figure-1