

INDEX ZIPPY SWITCHES DESIGN

WATER PROOF SWITCHES
DW32 SERIES



009

WATER PROOF SWITCHES
DFW32 (IP67) SERIES



012

WATER PROOF SWITCHES
DW33 SERIES



014

WATER PROOF SWITCHES
DW33 (IP67) SERIES



017

WATER PROOF SWITCHES
DW51 SERIES



019

WATER PROOF SWITCHES
DW51(IP67) SERIES



023

WATER PROOF SWITCHES
DW52 SERIES



025

WATER PROOF SWITCHES
DW52(IP67) SERIES



028

WATER PROOF SWITCHES
MDU-DFW SERIES



030

WATER PROOF SWITCHES
MDU-DFW(IP67) SERIES



034

WATER PROOF SWITCHES
DFW SERIES



036

WATER PROOF SWITCHES
DFW (IP67) SERIES



041

WATER PROOF SWITCHES DW SERIES



045

WATER PROOF SWITCHES DW (IP67) SERIES



049

WATER PROOF SWITCHES DW2 SERIES



051

WATER PROOF SWITCHES DW2 (IP67) SERIES



055

WATER PROOF SWITCHES DW3 SERIES



057

WATER PROOF SWITCHES DW3 (IP67) SERIES



060

WATER PROOF SWITCHES SW SERIES



062

WATER PROOF SWITCHES SW (IP67) SERIES



066

WATER PROOF SWITCHES SW1 SERIES



068

WATER PROOF SWITCHES SW1 (IP67) SERIES



072

WATER PROOF SWITCHES SW2 SERIES



074

WATER PROOF SWITCHES SW2 (IP67) SERIES



078

INDEX ZIPPY SWITCHES DESIGN

WATER PROOF SWITCHES VW1 SERIES



080

WATER PROOF SWITCHES VW1 (IP67) SERIES



084

WATER PROOF SWITCHES MP SERIES



086

MICRO SWITCHES DS SERIES



87

MICRO SWITCHES DS1 SERIES



89

MICRO SWITCHES DA SERIES



91

MICRO SWITCHES DF-M SERIES



93

MICRO SWITCHES DF SERIES



97

MICRO SWITCHES DF3 SERIES



101

MICRO SWITCHES DM SERIES



105

MICRO SWITCHES DW51(IP50) SERIES



109

MICRO SWITCHES SM SERIES



113

TERMINAL TYPES(THE thickness of each terminal is 0.4 mm)

A TYPE

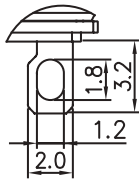

E- TERMINAL C TYPE

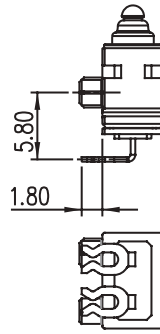

E- TERMINAL D TYPE

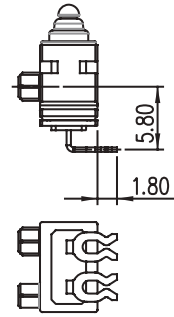

P TYPE

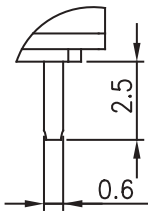

Y- TERMINAL C TYPE

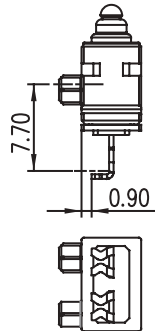

Y- TERMINAL D TYPE

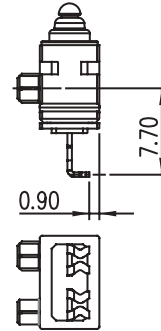

COVER TYPES (PILLAR & TRAVEL TYPES)

A TYPE

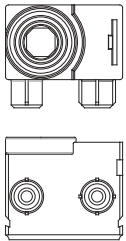

OPERATING CHARACTERISTICS

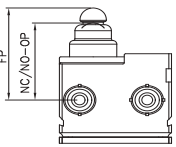
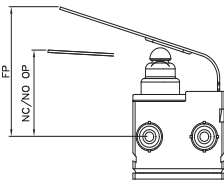
SWITCH TYPE	PART SUFFIX	OF Max (gf)		FP Max (mm)	NC/NO-OP (mm)	NC/NO-OT Min.(mm)
		H				
DW32- □□ -00 □□ -Z		H	160	7.7	7.1±0.25	1.75
DW32- □□ -01 □□ -Z		H	150	12.0	8.3±1.25	-

CAUTIONS:

注意事項

Terminal EC, ED, YC, and YD are not designed for soldering. Please do not solder wires with these terminal types.

端子型式EC, ED, YC 以及YD 不適用於焊線或焊接。

1. Do not handle the switch in a way that may cause damage to the sealed rubber & switch sealing.
使用開關時，請勿損壞開關防水矽膠罩及開關防水膠。
2. To ensure the best performance of the switch, when handling/installing the switch, please do not apply uneven pressure to the direction indicated by the arrow in (Figure 1). Any uneven pressure or pressure direction other than the operating direction might be harmful or damage the switch performance.
為確保開關正常運作，安裝及取用開關時，請勿直接施加壓力在(圖-1)中箭頭所指示的方向。如圖所示，任何不對稱的壓力或作動方向以外的壓力都不適用在開關按柄上。
3. Do not exceed the end position (EP) and over travel (OT). This could cause operation failure.
設計按壓位置，請勿超過開關下死點及超出行程，以避免開關失效。
4. Avoid applying any grease/oil and chemicals on the switch rubber.
請避免沾附任何油脂或者化學物質在開關的矽膠防水罩上。
5. < Important > To prevent deterioration of contact reliability, fork terminals should not be deformed in any situation. In order to prevent the deformation of the fork terminals, please use a special tooling to keep the switch vertical to the actual equipment. When inserting the fork terminal to the actual equipment, please make sure the fork terminal is well-supported, As shown in (Figure-2)
<重要> 為防止叉形端子變形而導致接觸可靠性下降，應使用專用工具安裝叉形端子開關，以使其保持垂直於實際設備的狀態，並在支撐端子的同時插入端子。建議安裝方式請參照(圖-2)。
6. < Suggestion > After the installation of the switch, please seal the terminal part properly to prevent the deterioration of the contact reliability due to vibration, impact, humidity and gas. Before the sealing process, please make sure the fork terminal fixed on the equipment. Please selection a sealing material that does not cause sulfuration, oxidation or generation of low molecular siloxane gas.
<建議> 在端子部上使用密封材料，將開關完全固定並密封端子部，以防止由於開關的叉形端子和實際設備的端子因振動、衝擊、潮濕和氣體而導致連接部分的接觸可靠性下降。（切勿使用未密封的開關）此外，有必要選擇不會引起硫化、氧化或低分子矽氧烷氣體生成的密封材料，因為存在因密封材料而導致接觸失敗的風險。為了選擇密封材料，應事先通過實際設備進行充分驗證。
7. < Important > The contact reliability may highly deteriorate due to unmatched materials or inaccurate of the connection between fork terminal and the matting equipment. Please contact your Zippy representative before using fork terminal type switch.
<重要> 由於使用不匹配的材料或叉形端子與設備裝配不精準，端子連接部分的接觸可靠性可能會大大降低。如果您考慮使用叉形端子類型，請務必諮詢我們。

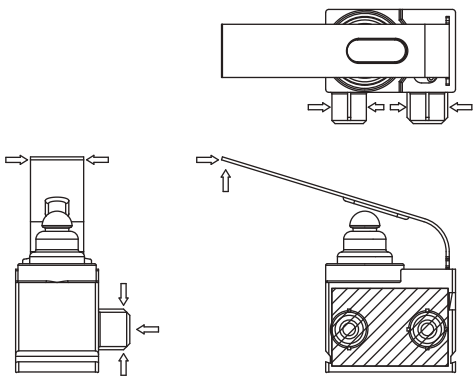

Figure-1

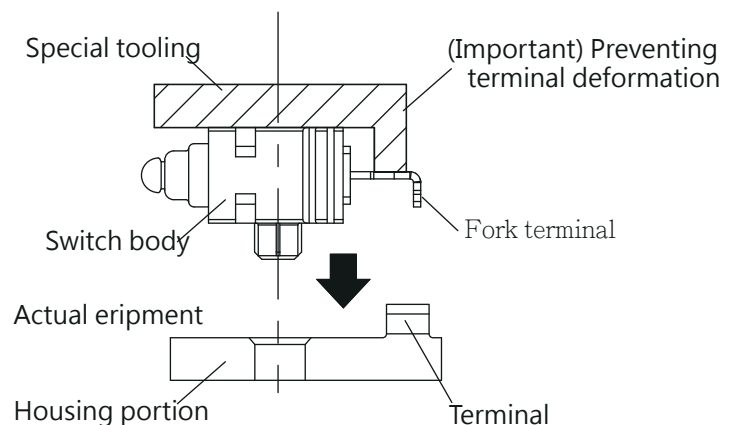

Figure-2

CAUTIONS:

注意事項

Terminal EC, ED, YC, and YD are not designed for soldering. Please do not solder wires with these terminal types.

端子型式EC, ED, YC 以及YD 不適用於焊線或焊接。

1. Do not handle the switch in a way that may cause damage to the sealed rubber & switch sealing.
使用開關時，請勿損壞開關防水矽膠罩及開關防水膠。
2. Wires should not be dragged.
使用帶線型式時，請注意避免拉扯線材。
3. To ensure the best performance of the switch, when handling/installing the switch, please do not apply uneven pressure to the direction indicated by the arrow in (Figure 1). Any uneven pressure or pressure direction other than the operating direction might be harmful or damage the switch performance.
為確保開關正常運作，安裝及取用開關時，請勿直接施加壓力在(圖-1)中箭頭所指示的方向。如圖所示，任何不對稱的壓力或作動方向以外的壓力都不適用在開關按柄上。
4. Do not exceed the end position (EP) and over travel (OT). This could cause operation failure.
設計按壓位置，請勿超過開關下死點及超出行程，以避免開關失效。
5. Avoid applying any grease/oil and chemicals on the switch rubber.
請避免沾附任何油脂或者化學物質在開關的矽膠防水罩上。
6. < Important > To prevent deterioration of contact reliability, fork terminals should not be deformed in any situation. In order to prevent the deformation of the fork terminals, please use a special tooling to keep the switch vertical to the actual equipment. When inserting the fork terminal to the actual equipment, please make sure the fork terminal is well-supported, As shown in (Figure-2)
<重要> 為防止叉形端子變形而導致接觸可靠性下降，應使用專用工具安裝叉形端子開關，以使其保持垂直於實際設備的狀態，並在支撐端子的同時插入端子。建議安裝方式請參照(圖-2)。
7. < Suggestion > After the installation of the switch, please seal the terminal part properly to prevent the deterioration of the contact reliability due to vibration, impact, humidity and gas. Before the sealing process, please make sure the fork terminal fixed on the equipment. Please selection a sealing material that does not cause sulfuration, oxidation or generation of low molecular siloxane gas.
<建議> 在端子部上使用密封材料，將開關完全固定並密封端子部，以防止由於開關的叉形端子和實際設備的端子因振動、衝擊、潮濕和氣體而導致連接部分的接觸可靠性下降。(切勿使用未密封的開關)此外，有必要選擇不會引起硫化、氧化或低分子矽氧烷氣體生成的密封材料，因為存在因密封材料而導致接觸失敗的風險。為了選擇密封材料，應事先通過實際設備進行充分驗證。
8. < Important > The contact reliability may highly deteriorate due to unmatched materials or inaccurate of the connection between fork terminal and the matting equipment. Please contact your Zippy representative before using fork terminal type switch.
<重要> 由於使用不匹配的材料或叉形端子與設備裝配不精準，端子連接部分的接觸可靠性可能會大大降低。如果您考慮使用叉形端子類型，請務必諮詢我們。

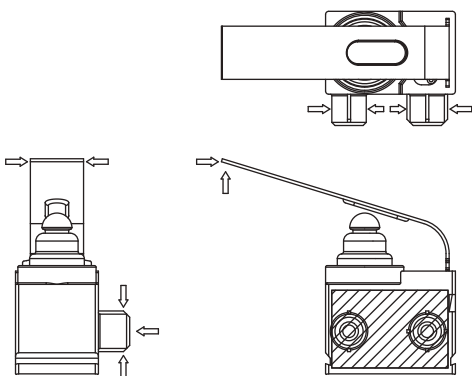

Figure-1

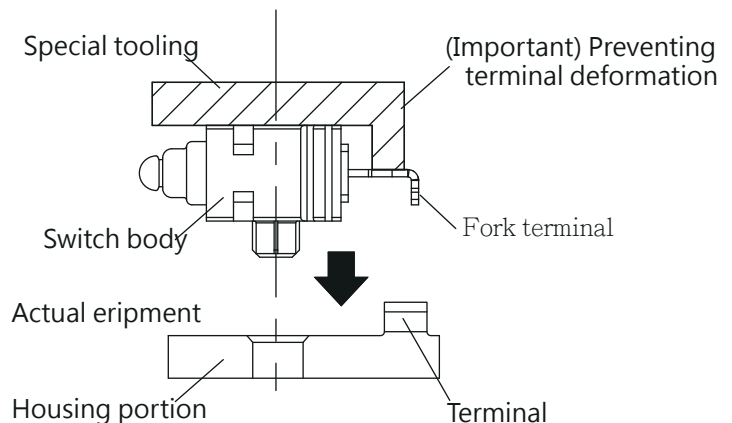
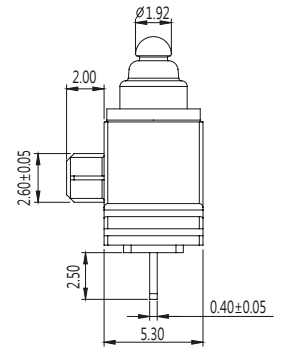
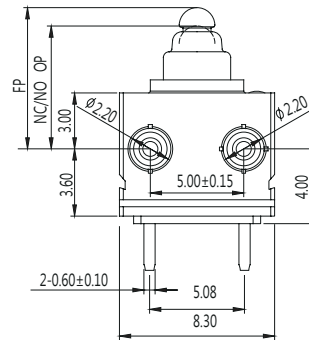

Figure-2

WATER PROOF SWITCHES

DIMENSIONS

Unless otherwise specified, a tolerance of $\pm 0.4\text{mm}$ applies to all dimensions



DW33 SERIES

SPECIFICATIONS

Contact Resistance (initial)

Max. 500m Ω

Measured by ohm meter -Open Voltage < 1VDC, Driver current -100mA

Insulation Resistance (at 500VDC/minute)

Min. 100M Ω

Dielectric Strength

Min. 500VAC(50-60HZ)/minute between Live parts.

Operating Temperature Range

-40°C to 85°C (with no icing)

Vibration

10~55Hz, displacement 0.75 mm (p-p)

Electrical Service Life

50mA 16VDC- Min. 150,000 operations

100mA 12VDC- Min. 300,000 operations

1mA 5VDC- Min. 300,000 operations

Electrical Operating Frequency

Max. 120 operations per minute

Operating application of the switch

Set the switch pushing distance from 60% to 90% of the specified OT value

Degree of Protection

IP67 (excluding the terminals on terminal models)

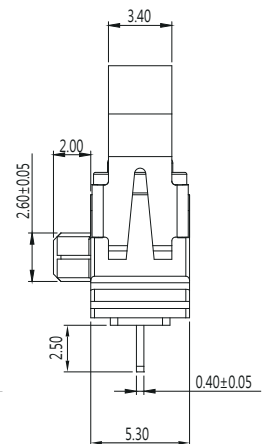
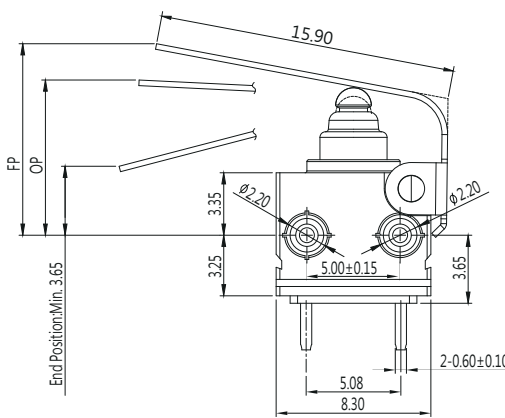

CONTACT CONFIGURATION

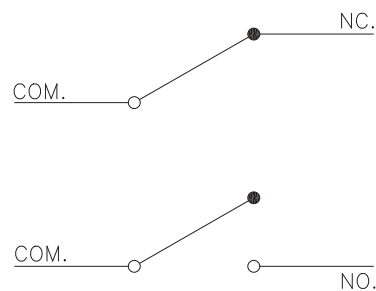

APPLICATION

Automobiles

(detection of door opening and closing and shift lever position, etc.)

Household appliances

(propane stoves, vacuum cleaners, air conditioners, washing machines, etc.)

MOUNTING HOLES FOR PCB TERMINAL

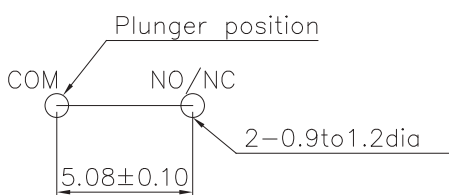

COVER TYPES (PILLAR & TRAVEL TYPES)

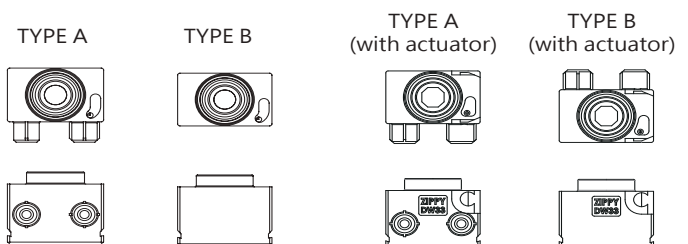

TERMINAL TYPES(THE thickness of each terminal is 0.4 mm)

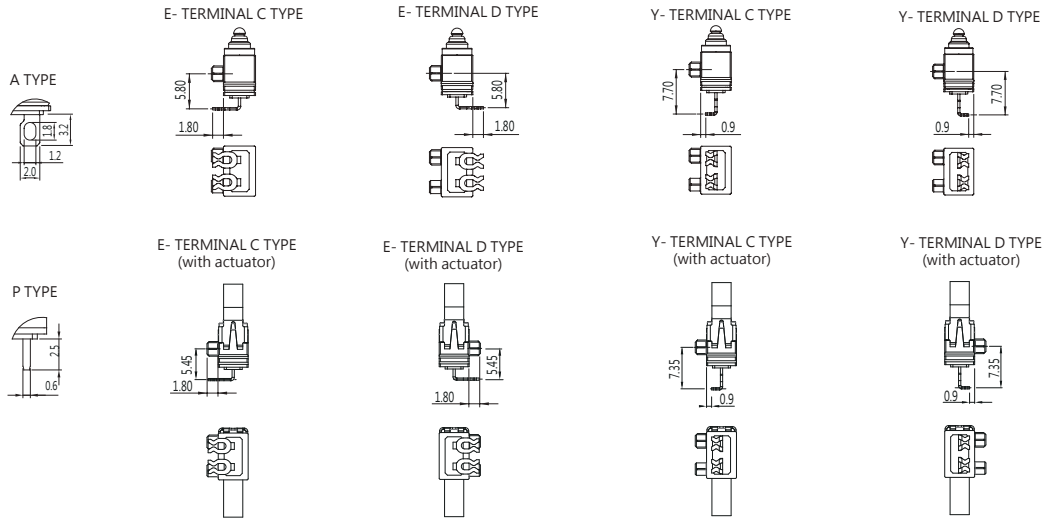

ORDERING INFORMATION

D W 33 — P 1 — S — Y C — 1 — A — 0 A — Z

SERIES PREFIX	CODE	RATING CURRENT	CODE	OPERATING FORCE	CODE	TERMINAL TYPE	CODE	CIRCUIT ARRANGEMENT	CODE	PILLAR TYPE	SPECIAL CODE	ROHS CODE
	P1	50mA 16VDC 100mA 12VDC 1mA 5VDC Contact Plated Silver	S	STANDARD	A		1	S.P.S.T-NO.	A			
					P		2	S.P.S.T-NC.	B			
					EC							
					ED							
					YC							
					YD							

DIMENSIONS

CODE	L1	H	A	B	C	D	P
A	2.0	3.0	∅2.2	∅2.2	2.6	2.6	5.0

(with actuator)

D W 33 — P 1 — S — S — 0 0 — Y C — 1 — A — 0 A — Z

SERIES PREFIX	CODE	RATING CURRENT	CODE	OPERATING FORCE	EXTERNAL SNAP-FIT LEVER	CODE	ACTUATOR TYPE	CODE	TERMINAL TYPE	CODE	CIRCUIT ARRANGEMENT	CODE	PILLAR TYPE	SPECIAL CODE	ROHS CODE
	P1	50mA 16VDC 100mA 12VDC 1mA 5VDC Contact Plated Silver	S	STANDARD	S	EXTERNAL	00		A		1	S.P.S.T-NO.	A		
							02		P		2	S.P.S.T-NC.	B		
									EC						
									ED						
									YC						
									YD						

DIMENSIONS

CODE	L1	H	A	B	C	D	P
A	2.0	3.35	∅2.2	∅2.2	2.6	2.6	5.0

OPERATING CHARACTERISTICS

SWITCH TYPE	PART SUFFIX	OF Max (mm)	FP Max (mm)	NC/NO-OP (mm)	NC/NO-OT Min.(mm)
DW33-P1S- □□ -Z		122	7.7	7.1±0.25	1.75
DW33-P1S-500 □□ -Z		122	8.05	7.45±0.25	1.75
DW33-P1S-502 □□ -Z		35	12.0	9.75±1.35	1.75

CAUTIONS:

注意事項

Terminal EC, ED, YC, and YD are not designed for soldering. Please do not solder wires with these terminal types.

端子型式EC, ED, YC 以及YD 不適用於焊線或焊接。

1. Do not handle the switch in a way that may cause damage to the sealed rubber & switch sealing.
使用開關時，請勿損壞開關防水矽膠罩及開關防水膠。
2. To ensure the best performance of the switch, when handling/installing the switch, please do not apply uneven pressure to the direction indicated by the arrow in (Figure 1). Any uneven pressure or pressure direction other than the operating direction might be harmful or damage the switch performance.
為確保開關正常運作，安裝及取用開關時，請勿直接施加壓力在(圖-1)中箭頭所指示的方向。如圖所示，任何不對稱的壓力或作動方向以外的壓力都不適用在開關按柄上。
3. Do not exceed the end position (EP) and over travel (OT). This could cause operation failure.
設計按壓位置，請勿超過開關下死點及超出行程，以避免開關失效。
4. Avoid applying any grease/oil and chemicals on the switch rubber.
請避免沾附任何油脂或者化學物質在開關的矽膠防水罩上。
5. < Important > To prevent deterioration of contact reliability, fork terminals should not be deformed in any situation. In order to prevent the deformation of the fork terminals, please use a special tooling to keep the switch vertical to the actual equipment. When inserting the fork terminal to the actual equipment, please make sure the fork terminal is well-supported, As shown in (Figure-2)
<重要> 為防止叉形端子變形而導致接觸可靠性下降，應使用專用工具安裝叉形端子開關，以使其保持垂直於實際設備的狀態，並在支撐端子的同時插入端子。建議安裝方式請參照(圖-2)。
6. < Suggestion > After the installation of the switch, please seal the terminal part properly to prevent the deterioration of the contact reliability due to vibration, impact, humidity and gas. Before the sealing process, please make sure the fork terminal fixed on the equipment. Please selection a sealing material that does not cause sulfuration, oxidation or generation of low molecular siloxane gas.
<建議> 在端子部上使用密封材料，將開關完全固定並密封端子部，以防止由於開關的叉形端子和實際設備的端子因振動、衝擊、潮濕和氣體而導致連接部分的接觸可靠性下降。（切勿使用未密封的開關）此外，有必要選擇不會引起硫化、氧化或低分子矽氧烷氣體生成的密封材料，因為存在因密封材料而導致接觸失敗的風險。為了選擇密封材料，應事先通過實際設備進行充分驗證。
7. < Important > The contact reliability may highly deteriorate due to unmatched materials or inaccurate of the connection between fork terminal and the matting equipment. Please contact your Zippy representative before using fork terminal type switch.
<重要> 由於使用不匹配的材料或叉形端子與設備裝配不精準，端子連接部分的接觸可靠性可能會大大降低。如果您考慮使用叉形端子類型，請務必諮詢我們。

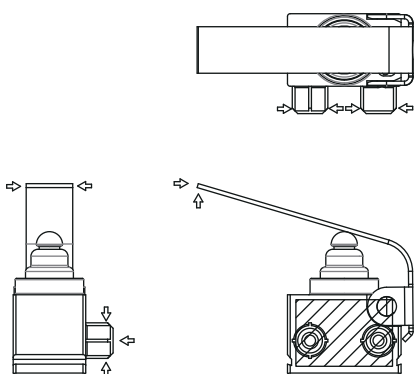

Figure-1

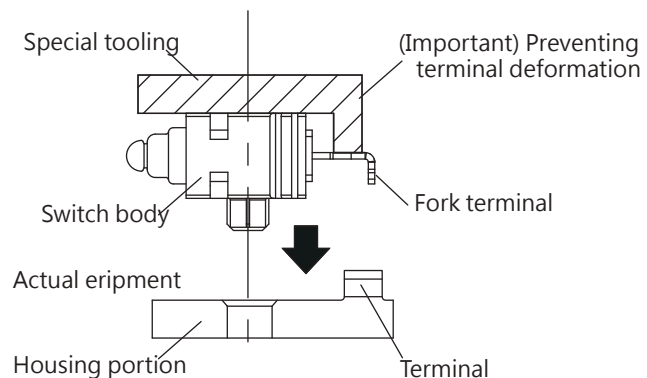

Figure-2

WATER PROOF SWITCHES

DIMENSIONS

Unless otherwise specified, a tolerance of $\pm 0.4\text{mm}$ applies to all dimensions.



DW33(IP67) SERIES

APPLICATIONS

- Automobiles
(detection of door opening and closing and shift lever position, etc.)
- Household appliances
(propane stoves, vacuum cleaners, air conditioners, washing machines, etc.)

※ For the specification, please refer to DW33 SERIES. ※

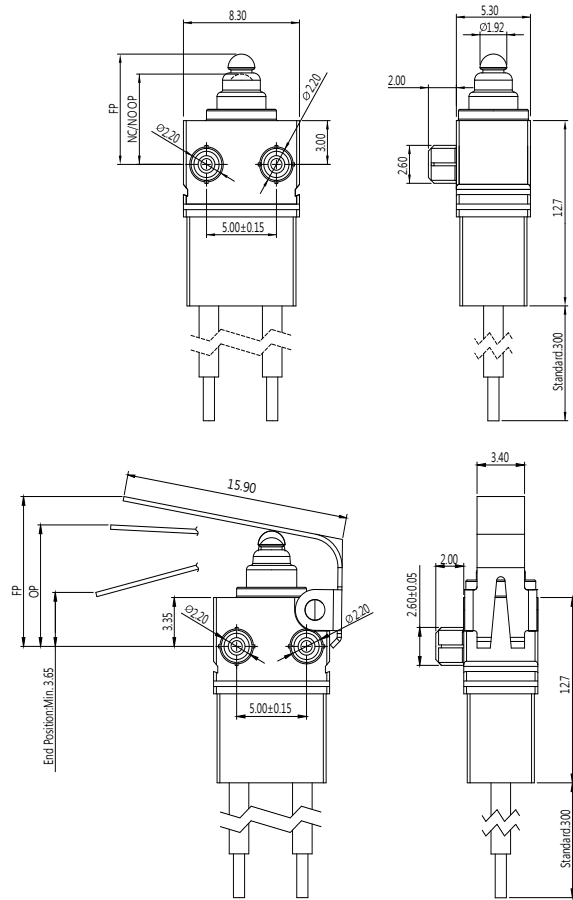

ORDERING INFORMATION

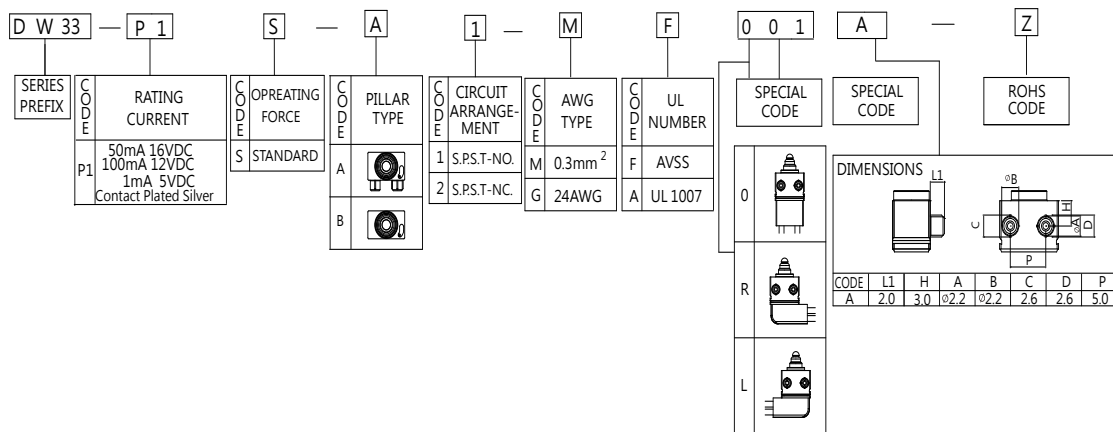

(with actuator)

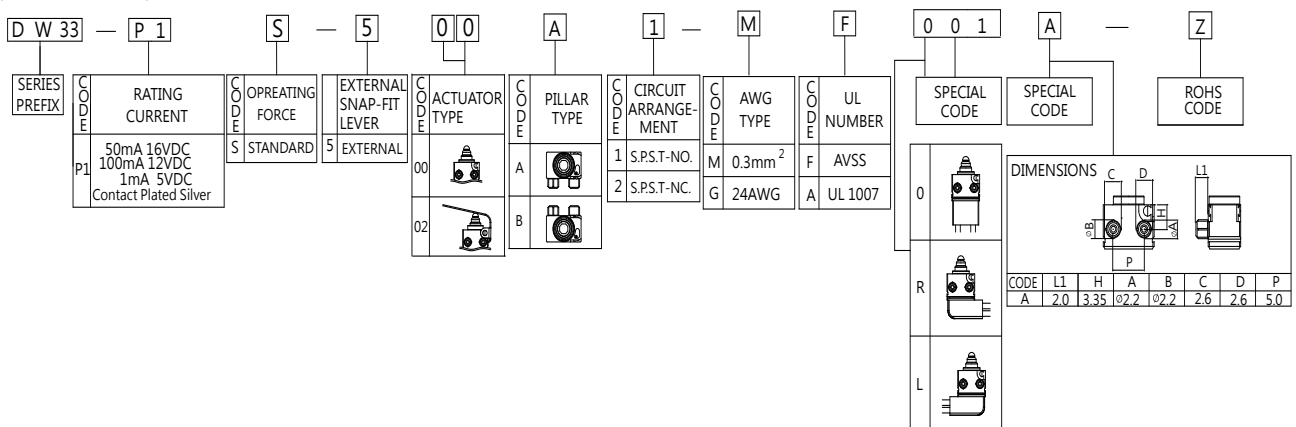

CAUTIONS:

注意事項

Terminal EC, ED, YC, and YD are not designed for soldering. Please do not solder wires with these terminal types.

端子型式EC, ED, YC 以及YD 不適用於焊線或焊接。

1. Do not handle the switch in a way that may cause damage to the sealed rubber & switch sealing.
使用開關時，請勿損壞開關防水矽膠罩及開關防水膠。
2. Wires should not be dragged.
使用帶線型式時，請注意避免拉扯線材。
3. To ensure the best performance of the switch, when handling/installing the switch, please do not apply uneven pressure to the direction indicated by the arrow in (Figure 1). Any uneven pressure or pressure direction other than the operating direction might be harmful or damage the switch performance.
為確保開關正常運作，安裝及取用開關時，請勿直接施加壓力在(圖-1)中箭頭所指示的方向。如圖所示，任何不對稱的壓力或作動方向以外的壓力都不適用在開關按柄上。
4. Do not exceed the end position (EP) and over travel (OT). This could cause operation failure.
設計按壓位置，請勿超過開關下死點及超出行程，以避免開關失效。
5. Avoid applying any grease/oil and chemicals on the switch rubber.
請避免沾附任何油脂或者化學物質在開關的矽膠防水罩上。
6. < Important > To prevent deterioration of contact reliability, fork terminals should not be deformed in any situation. In order to prevent the deformation of the fork terminals, please use a special tooling to keep the switch vertical to the actual equipment. When inserting the fork terminal to the actual equipment, please make sure the fork terminal is well-supported, As shown in (Figure-2)
<重要> 為防止叉形端子變形而導致接觸可靠性下降，應使用專用工具安裝叉形端子開關，以使其保持垂直於實際設備的狀態，並在支撐端子的同時插入端子。建議安裝方式請參照(圖-2)。
7. < Suggestion > After the installation of the switch, please seal the terminal part properly to prevent the deterioration of the contact reliability due to vibration, impact, humidity and gas. Before the sealing process, please make sure the fork terminal fixed on the equipment. Please selection a sealing material that does not cause sulfuration, oxidation or generation of low molecular siloxane gas.
<建議> 在端子部上使用密封材料，將開關完全固定並密封端子部，以防止由於開關的叉形端子和實際設備的端子因振動、衝擊、潮濕和氣體而導致連接部分的接觸可靠性下降。（切勿使用未密封的開關）此外，有必要選擇不會引起硫化、氧化或低分子矽氧烷氣體生成的密封材料，因為存在因密封材料而導致接觸失敗的風險。為了選擇密封材料，應事先通過實際設備進行充分驗證。
8. < Important > The contact reliability may highly deteriorate due to unmatched materials or inaccurate of the connection between fork terminal and the matting equipment. Please contact your Zippy representative before using fork terminal type switch.
<重要> 由於使用不匹配的材料或叉形端子與設備裝配不精準，端子連接部分的接觸可靠性可能會大大降低。如果您考慮使用叉形端子類型，請務必諮詢我們。

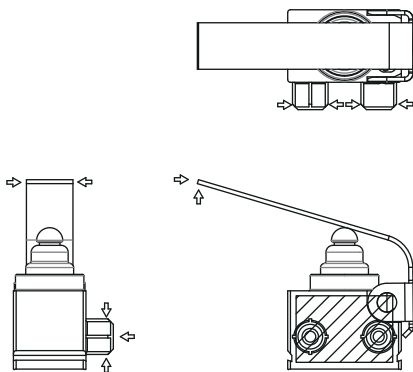

Figure-1

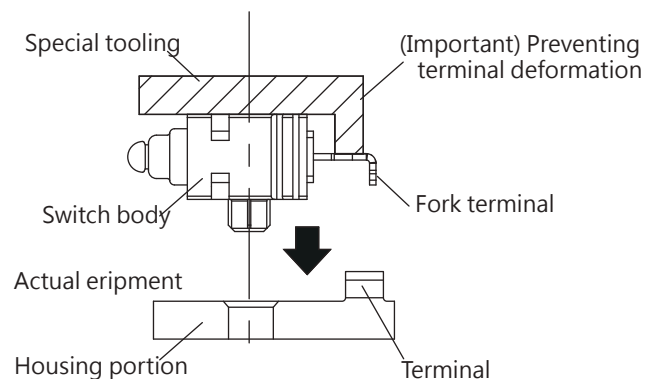

Figure-2

WATER PROOF SWITCHES



DW51 SERIES

SPECIFICATIONS

Contact Resistance(initial)

Max. 100 mΩ

Measured by ohm meter - open voltage <1 VDC, driver current -100 mA

Insulation Resistance (at 500VDC/minute)

Min. 100MΩ

Dielectric Strength

Min. 400VAC(50-60HZ)/minute between Live parts.

Min. 1300VAC(50-60HZ)/minute between Live parts and dead metal parts

Operating Temperature Range

-40°C to 85°C (with no icing)

Vibration

10~55Hz, displacement 0.75 mm (p-p)

Electrical Service Life

0.1A - Min. 100,000 operations

3A - Min. 10,000 operations

Electrical Operating Frequency

10~30 operations per minute

Mechanical Service Life

Min. 500,000 operations

Mechanical Operating Frequency

120 operations per minute

Operating application of the switch

Set the switch pushing distance from 60% to 90% of the specified OT value

APPLICATIONS

Automotive (Seat Belt, Door Latch, Engine Hood, Door Trunk), Air Conditioner, Communication, Security System, Electric Tooth Brush, Toy

DIMENSIONS

Unless otherwise specified, a tolerance of ±0.4mm applies to all dimensions.

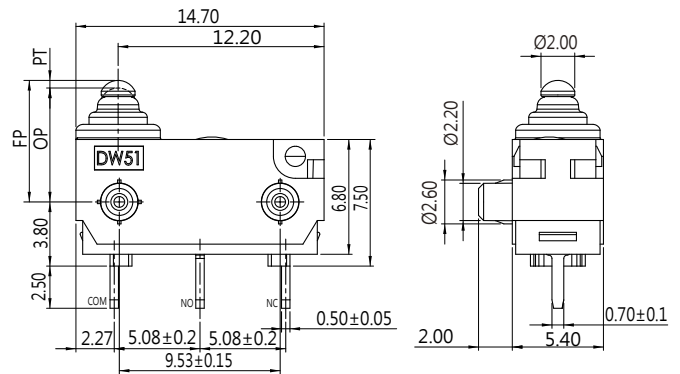

CONTACT CONFIGURATION

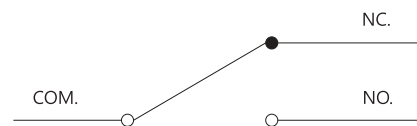

MOUNTING HOLES FOR PCB TERMINAL

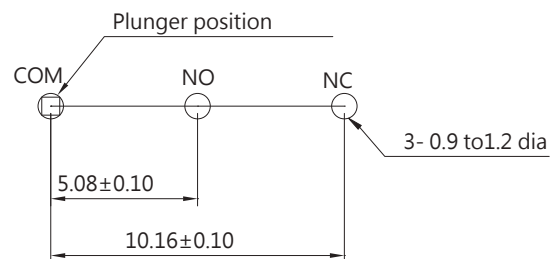

PILLAR PITCH

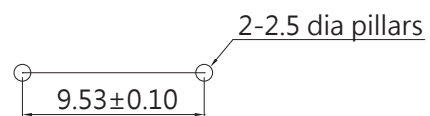

CERTIFICATE INFORMATION

Model Name	UL, cUL	ENEC
DW51-P1 or G1	0.1RA 12 VDC, μ T55 1E5 0.1RA 125 VAC, μ T55 1E4	0.1A 12 VDC, μ T55 1E5 0.1A 125 VAC, μ T55 1E4
DW51-03 or G3	3RA 12 VDC, μ T55 1E5 3GPA 125 VAC, μ T55 1E4	3A 12 VDC, μ T55 1E5 3A 125 VAC, μ T55 1E4

TERMINAL TYPES (THE thickness of each terminal is 0.5mm)

P TYPE

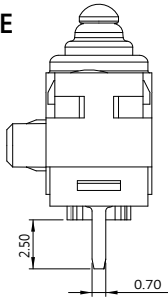

COVER TYPES (PILLAR & TRAVEL TYPES)

A TYPE

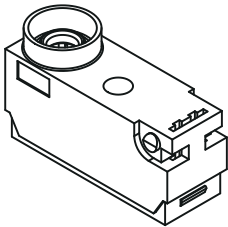

B TYPE

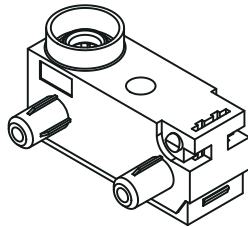

C TYPE

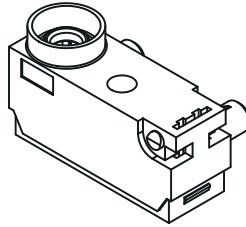

D TYPE

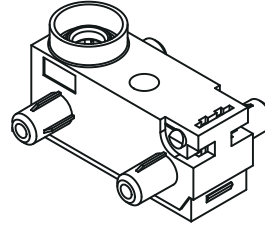

ORDERING INFORMATION

DW51

SERIES
PREFIX

03

CODE	RATING CURRENT
G1	0.1A 125VAC Contact plated gold
P1	0.1A 125VAC
G3	3A 125VAC Contact plated gold
03	3A 125VAC

S

CODE	OPERATING FORCE
S	STANDARD

01

CODE	ACTUATOR TYPE (for DW51)
00	
01	

P

CODE	TERMINAL TYPE
P	

0

CODE	CIRCUIT ARRANGEMENT
0	S.P.D.T
1	S.P.S.T NO
2	S.P.S.T NC

A

CODE	PILLAR TYPE
A	
B	
C	
D	

0A

SPECIAL CODE

Z

ROHS CODE

DIMENSIONS

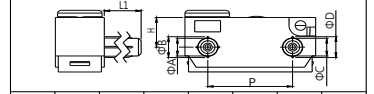

CODE	L1	H	ΦA	ΦB	ΦC	ΦD	P
	5.0	3.7	2.2	2.6	2.2	2.6	9.53
A	2.0	3.7	2.2	2.6	2.2	2.6	9.53
B	3.5	3.7	2.2	2.6	2.2	2.6	9.53

OPERATING CHARACTERISTICS

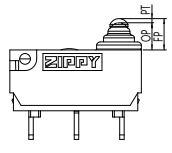
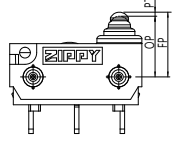
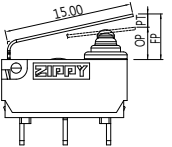
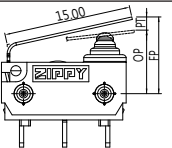
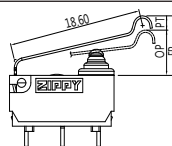
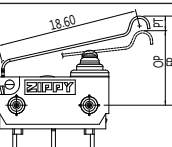
SWITCH TYPE	PART SUFFIX	OF Max (gf)		OP (mm)	PT Max (mm)	OT Min (mm)	MD Max (mm)	FP Max (mm)	RF Min (gf)
DW51- □□ S-00 □□ -Z		S	130	3.05±0.2	0.8	0.8	0.3	3.65	35
				6.75±0.2				7.35	
DW51- □□ S-01 □□ -Z		S	195	3.7±0.5	3.85	1.35	0.5	7.0	55
				7.4±0.5				10.7	
DW51- □□ S-04 □□ -Z		S	160	6.2±0.8	4.8	1.65	0.7	10.1	45
				9.9±0.8				13.8	

CAUTIONS:

注意事項

1. Do not handle the switch in a way that may cause damage to the sealed rubber & switch sealing.
使用開關時，請勿損壞開關防水矽膠罩及開關防水膠。
2. To ensure the best performance of the switch, when handling/installing the switch, please do not apply uneven pressure to the direction indicated by the arrow in Figure 1. Any uneven pressure or pressure direction other than the operating direction might be harmful or damage the switch performance.
為確保開關正常運作，安裝及取用開關時，請勿直接施加壓力在圖-1中箭頭所指示的方向。如圖所示，任何不對稱的壓力或作動方向以外的壓力都不適用在開關按柄上。
3. Do not exceed the end position (EP) and over travel (OT). This could cause operation failure. (Figure-2)
圖示設計按壓位置，請勿超過開關下死點及超出行程，以避免開關失效。(圖2)
4. Avoid applying any grease/oil and chemicals on the switch rubber.
請避免沾附任何油脂或者化學物質在開關的矽膠防水罩上。

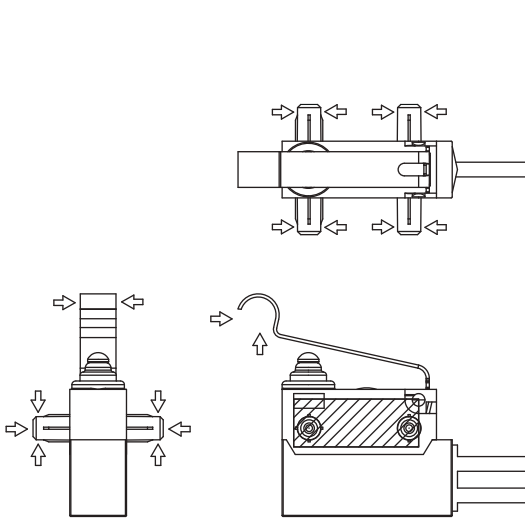

Figure-1

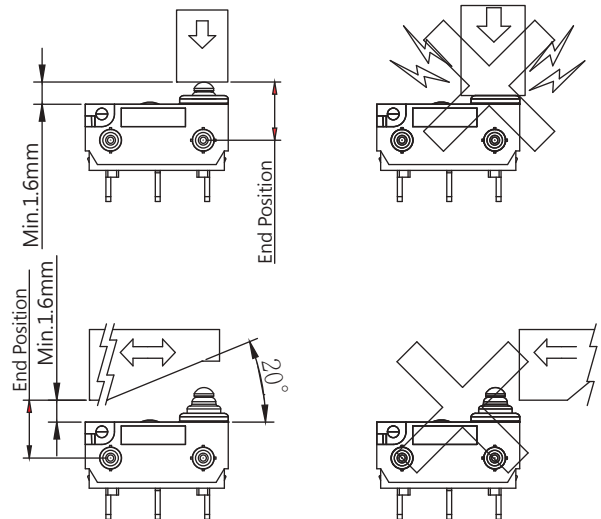

Figure-2

WATER PROOF SWITCHES



DW51 (IP67)SERIES

APPLICATIONS

Automotive (Seat Belt, Door Latch, Engine Hood, Door Trunk), Air Conditioner, Communication, Security System, Electric Tooth Brush, Toy

※ For the specification, please refer to DW51 SERIES. ※

DIMENSIONS

Unless otherwise specified, a tolerance of ±0.4mm applies to all dimensions.

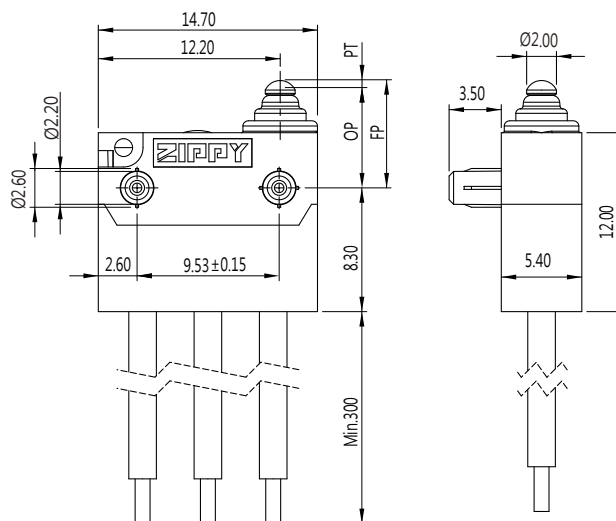

CERTIFICATE INFORMATION

Model Name	UL, cUL	ENEC
DW51-P1 or G1	0.1RA 12 VDC, μ T55 1E5 0.1RA 125 VAC, μ T55 1E4	0.1A 12 VDC, μ T55 1E5 0.1A 125 VAC, μ T55 1E4
DW51-03 or G3	3RA 12 VDC, μ T55 1E5 3GPA 125 VAC, μ T55 1E4	3A 12 VDC, μ T55 1E5 3A 125 VAC, μ T55 1E4

ORDERING INFORMATION

DW51 — 03 — S — 01 — R — O — A — E — A001A — Z

CODE	RATING CURRENT	OPERATING FORCE	ACTUATOR TYPE	WIRE SIDE	CIRCUIT ARRANGEMENT	PILLAR TYPE	AWG TYPE	UL NUMBER	SPECIAL CODE	ROHS CODE
G1	0.1A 125VAC Contact plated gold	STANDARD	00	O	0 S.P.D.T	A	E 20	A UL 1007		
P1	0.1A 125VAC		01	R	1 S.P.S.T.NO	B	F 22	C UL 1430		
G3	3A 125VAC Contact plated gold			L	2 S.P.S.T.NC	C	G 24	D UL 1061		
03	3A 125VAC					D	H 26			

DIMENSIONS

CODE	L1	H	ΦA	ΦB	ΦC	ΦD	P
A	5.0	3.7	2.2	2.6	2.2	2.6	9.53
B	2.0	3.7	2.2	2.6	2.2	2.6	9.53
B	3.5	3.7	2.2	2.6	2.2	2.6	9.53

CAUTIONS:

注意事項

1. Do not handle the switch in a way that may cause damage to the sealed rubber & switch sealing.
使用開關時，請勿損壞開關防水矽膠罩及開關防水膠。
2. Wires should not be dragged.
使用帶線型式時，請注意避免拉扯線材。
3. To ensure the best performance of the switch, when handling/installing the switch, please do not apply uneven pressure to the direction indicated by the arrow in Figure 1. Any uneven pressure or pressure direction other than the operating direction might be harmful or damage the switch performance.
為確保開關正常運作，安裝及取用開關時，請勿直接施加壓力在圖-1中箭頭所指示的方向。如圖所示，任何不對稱的壓力或作動方向以外的壓力都不適用在開關按柄上。
4. Do not exceed the end position (EP) and over travel (OT). This could cause operation failure. (Figure-2)
圖示設計按壓位置，請勿超過開關下死點及超出行程，以避免開關失效。(圖2)
5. Avoid applying any grease/oil and chemicals on the switch rubber.
請避免沾附任何油脂或者化學物質在開關的矽膠防水罩上。

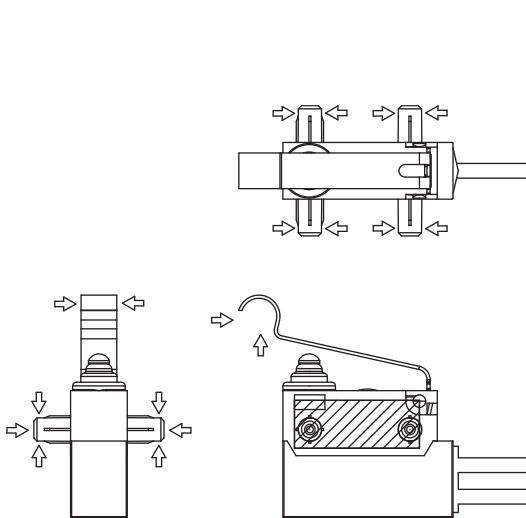

Figure-1

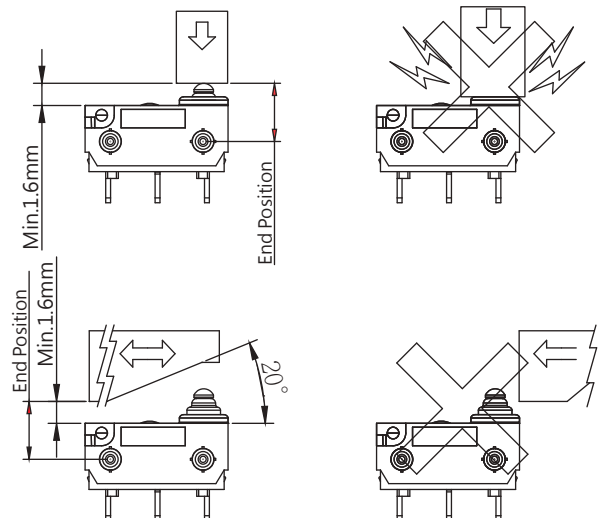

Figure-2

WATER PROOF SWITCHES



DIMENSIONS

Unless otherwise specified, a tolerance of $\pm 0.4\text{mm}$ applies to all dimensions.

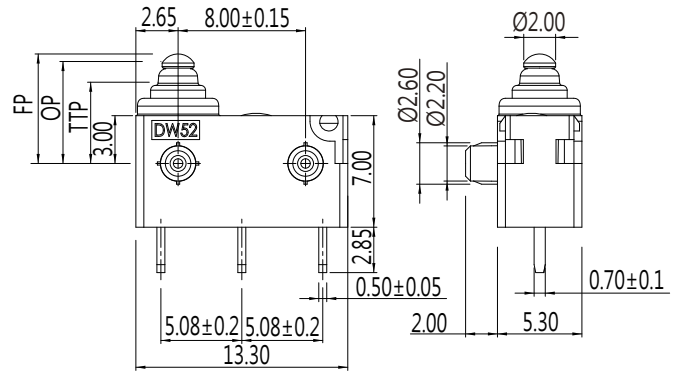

DW52 SERIES

SPECIFICATIONS

Contact Resistance(initial)

Max. 100 m Ω

Measured by ohm meter - open voltage <1 VDC, driver current -100 mA

Insulation Resistance (at 500VDC/minute)

Min. 100M Ω

Dielectric Strength

Min. 400VAC(50-60HZ)/minute between Live parts.

Min. 1300VAC(50-60HZ)/minute between Live parts and dead metal parts

Operating Temperature Range

-40°C to 85°C (with no icing)

Vibration

10~55Hz, displacement 0.75 mm (p-p)

Electrical Service Life

0.1A - Min. 100,000 operations

3A - Min. 10,000 operations

Electrical Operating Frequency

10~30 operations per minute

Mechanical Service Life

Min. 500,000 operations

Mechanical Operating Frequency

120 operations per minute

Operating application of the switch

Set the switch pushing distance from 60% to 90% of the specified OT value

APPLICATIONS

Automotive (Seat Belt, Door Latch, Engine Hood, Door Trunk), Air Conditioner, Communication, Security System, Electric Tooth Brush, Toy

CONTACT CONFIGURATION

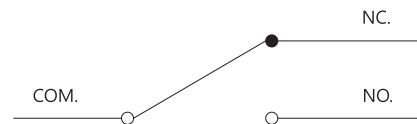

MOUNTING HOLES FOR PCB TERMINAL

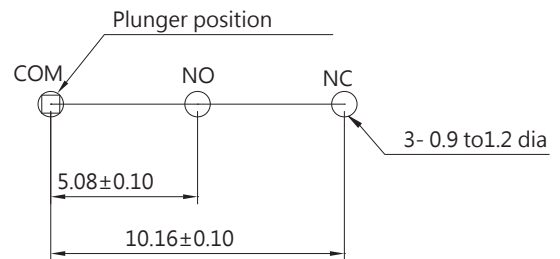

PILLAR PITCH

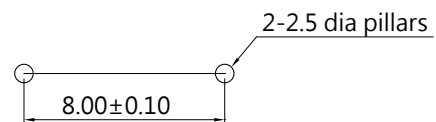

CERTIFICATE INFORMATION

Model Name	UL, cUL	ENEC
DW52-P1 or G1	0.1RA 12 VDC, μ T55 1E5 0.1RA 125 VAC, μ T55 1E4	0.1A 12 VDC, μ T55 1E5 0.1A 125 VAC, μ T55 1E4
DW52-03 or G3	3RA 12 VDC, μ T55 1E5 3GPA 125 VAC, μ T55 1E4	3A 12 VDC, μ T55 1E5 3A 125 VAC, μ T55 1E4

TERMINAL TYPES (THE thickness of each terminal is 0.5mm)

P TYPE

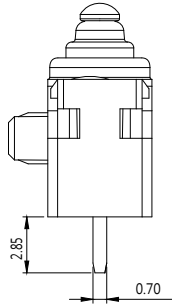

COVER TYPES (PILLAR & TRAVEL TYPES)

A TYPE

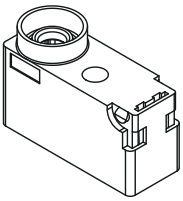

B TYPE

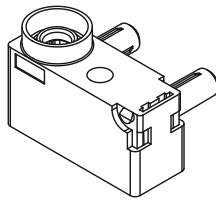

C TYPE

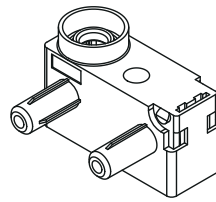

D TYPE

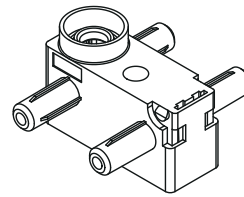

ORDERING INFORMATION

DW52 — 03 — S — 01 — P — 0 — A — 0A — Z

CODE	RATING CURRENT
G1	0.1A 125VAC Contact plated gold
P1	0.1A 125VAC
G3	3A 125VAC Contact plated gold
O3	3A 125VAC

CODE	OPERATING FORCE
S	STANDARD

CODE	ACTUATOR TYPE (for DW51)
00	
01	
A01	

CODE	TERMINAL TYPE
P	

CODE	CIRCUIT ARRANGEMENT
0	S.P.D.T
1	S.P.S.T NO
2	S.P.S.T NC

CODE	PILLAR TYPE
A	
B	
C	
D	

CODE	SPECIAL CODE	ROHS CODE
0A		Z

DIMENSIONS

CODE	L1	H	ΦA	ΦB	ΦC	ΦD	P
A	2.0	3.0	2.2	2.6	2.2	2.6	8.00

OPERATING CHARACTERISTICS

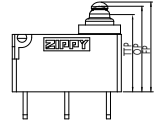
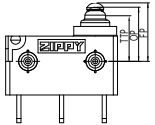
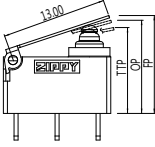
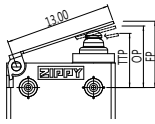
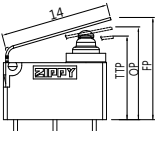
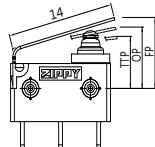
SWITCH TYPE	PART SUFFIX	OF Max (gf)	OP (mm)	TTP Max (mm)	OT Min (mm)	MD Max (mm)	FP Max (mm)	RF Min (gf)
DW52- □□ S-00 □□ -Z		S	130	10.4±0.2	9.1	1.1	0.25	11.2
				6.4±0.2	5.1			7.2
DW52- □□ S-01 □□ -Z		S	110	11.5±0.5	10	1.0	0.5	12.8
				7.5±0.5	6			8.8
DW52- □□ S-A01 □□ -Z		S	200	11.4±0.5	9.8	1.1	0.5	13.3
				7.4±0.5	5.8			9.3

CAUTIONS:

注意事項

1. Do not handle the switch in a way that may cause damage to the sealed rubber & switch sealing.
 使用開關時，請勿損壞開關防水矽膠罩及開關防水膠。

使用開關時，請勿損壞開關防水矽膠罩及開關防水膠。

2. To ensure the best performance of the switch, when handling/installing the switch, please do not apply uneven pressure to the direction indicated by the arrow in Figure 1. Any uneven pressure or pressure direction other than the operating direction might be harmful or damage the switch performance.

為確保開關正常運作，安裝及取用開關時，請勿直接施加壓力在圖-1中箭頭所指示的方向。如圖所示，任何不對稱的壓力或作動方向以外的壓力都不適用在開關按柄上。

3. Do not exceed the end position (EP) and over travel (OT). This could cause operation failure. (Figure-2)

圖示設計按壓位置，請勿超過開關下死點及超出行程，以避免開關失效。(圖2)

4. Avoid applying any grease/oil and chemicals on the switch rubber.

請避免沾附任何油脂或者化學物質在開關的矽膠防水罩上。

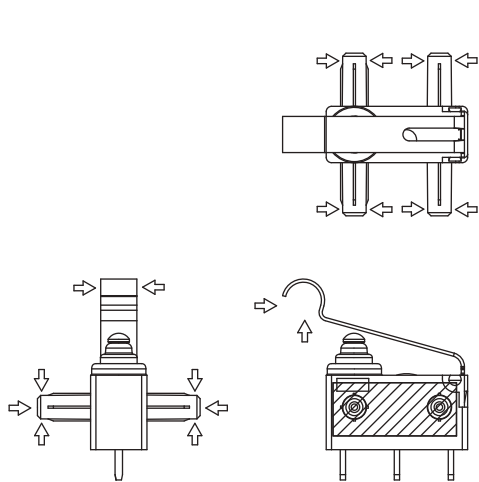

Figure-1

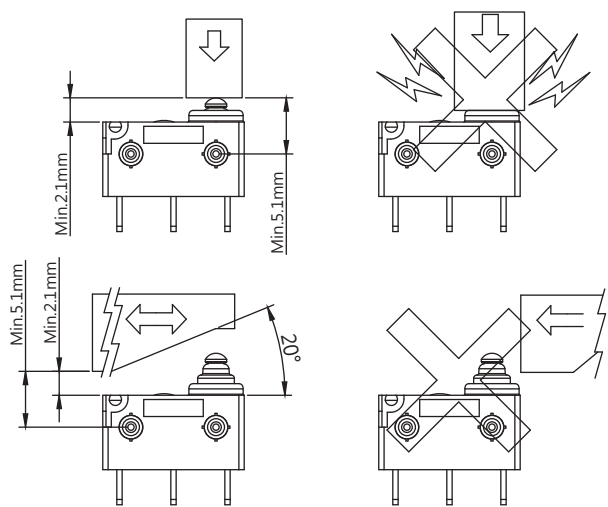

Figure-2

WATER PROOF SWITCHES



DW52 (IP67) SERIES

APPLICATIONS

Automotive (Seat Belt, Door Latch, Engine Hood, Door Trunk), Air Conditioner, Communication, Security System, Electric Tooth Brush, Toy

※ For the specification, please refer to DW52 SERIES. ※

DIMENSIONS

Unless otherwise specified, a tolerance of $\pm 0.4\text{mm}$ applies to all dimensions.

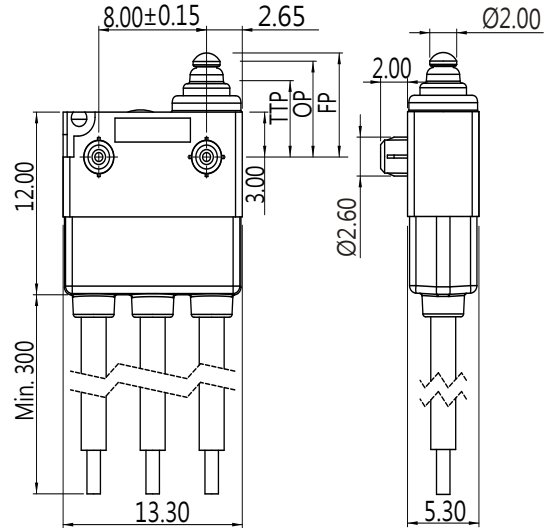

CERTIFICATE INFORMATION

Model Name	UL, cUL	ENEC
DW51-P1 or G1	0.1RA 12 VDC, μ T55 1E5 0.1RA 125 VAC, μ T55 1E4	0.1A 12 VDC, μ T55 1E5 0.1A 125 VAC, μ T55 1E4
DW51-03 or G3	3RA 12 VDC, μ T55 1E5 3GPA 125 VAC, μ T55 1E4	3A 12 VDC, μ T55 1E5 3A 125 VAC, μ T55 1E4

ORDERING INFORMATION

DW52	03	S	01	R	0	A	E	A	001A	Z
SERIES PREFIX	RATING CURRENT	OPERATING FORCE	ACTUATOR TYPE (for DW51)	WIRE SIDE	CIRCUIT ARRANGEMENT	PILLAR TYPE	AWG TYPE	UL NUMBER	SPECIAL CODE	ROHS CODE
G1	0.1A 125VAC Contact plated gold	S STANDARD	00	0	0 S.P.D.T	A	E 20	A UL 1007		
P1	0.1A 125VAC		01	R	1 S.P.S.T NO	B	F 22	C UL 1430		
G3	3A 125VAC Contact plated gold		A01	L	2 S.P.S.T NC	C	G 24	D UL 1061		
03	3A 125VAC					D	H 26			

DIMENSIONS							
CODE	L1	H	ΦA	ΦB	ΦC	ΦD	P
A	2.0	3.0	2.2	2.6	2.2	2.6	8.00

CAUTIONS:

注意事項

1. Do not handle the switch in a way that may cause damage to the sealed rubber & switch sealing.
使用開關時，請勿損壞開關防水矽膠罩及開關防水膠。
2. Wires should not be dragged.
使用帶線型式時，請注意避免拉扯線材。
3. To ensure the best performance of the switch, when handling/installing the switch, please do not apply uneven pressure to the direction indicated by the arrow in Figure 1. Any uneven pressure or pressure direction other than the operating direction might be harmful or damage the switch performance.
為確保開關正常運作，安裝及取用開關時，請勿直接施加壓力在圖-1中箭頭所指示的方向。如圖所示，任何不對稱的壓力或作動方向以外的壓力都不適用在開關按柄上。
4. Do not exceed the end position (EP) and over travel (OT). This could cause operation failure. (Figure-2)
圖示設計按壓位置，請勿超過開關下死點及超出行程，以避免開關失效。(圖2)
5. Avoid applying any grease/oil and chemicals on the switch rubber.
請避免沾附任何油脂或者化學物質在開關的矽膠防水罩上。

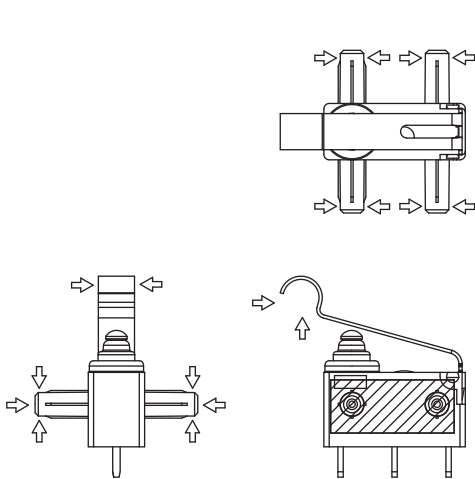

Figure-1

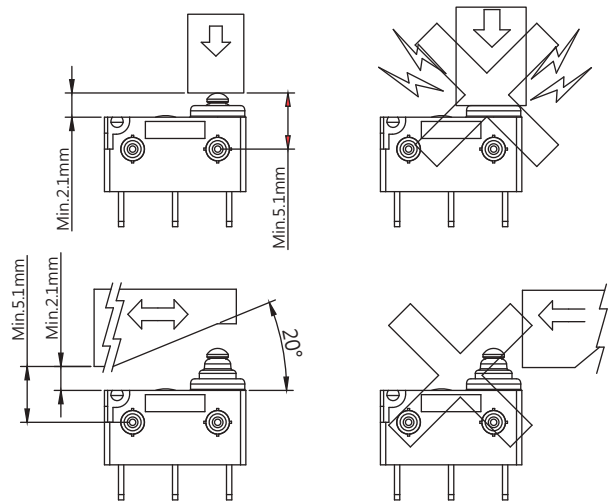

Figure-2

WATER PROOF SWITCHES



DIMENSIONS

Unless otherwise specified, a tolerance of $\pm 0.4\text{mm}$ applies to all dimensions.

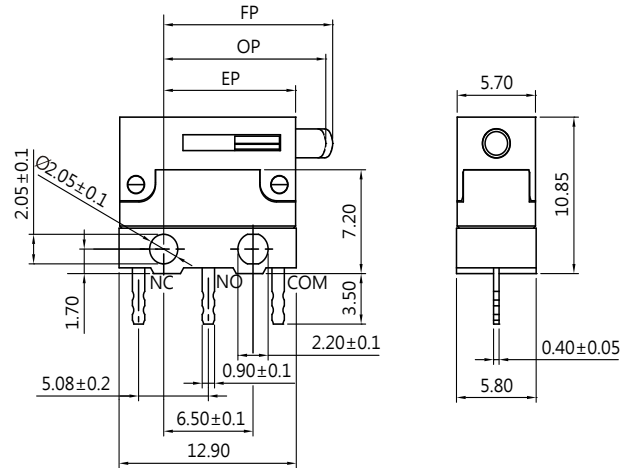

MDU-DFW SERIES

SPECIFICATIONS

Contact Resistance (initial)

Max. 100m Ω

(Measured by ohm meter-Open Voltage < 1VDC, Driver current-100mA)

Insulation Resistance (at 500VDC/minute)

Min. 100M Ω

Dielectric Strength

Min. 500VAC(50-60HZ)/minute between Live parts.

Min. 1500VAC(50-60HZ)/minute between Live parts and dead metal parts

Operating Temperature Range

-40°C to 85°C (with no icing)

Vibration

10~55Hz, displacement 0.75 mm (p-p)

Electrical Service Life

Min. 10,000 operations

Electrical Operating Frequency

10~30 operations per minute

Mechanical Service Life

Min. 1,000,000 operations

Mechanical Operating Frequency

120 operations per minute

Operating application of the switch

Set the switch pushing distance from 60% to 90% of the specified OT value

Degree of Protection

IP67 (excluding the terminals on terminal models)

APPLICATIONS

Automotive (Operation system, Engine area Interior)

Air conditioner, communication, Electric tooth brush, Toy

CONTACT CONFIGURATION

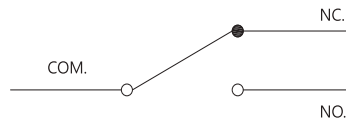

MOUNTING HOLES FOR PCB TERMINAL

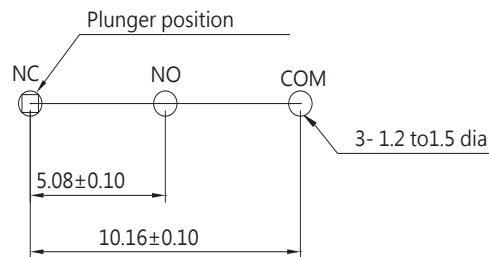

PART LIST OF THE PRODUCT

Item	Part Name	Part information	Note
1	Switch	DFW series	See the certificate information below
2	Cover Assembly	Hilltop Cover	
		Slide Button	
		Spring	

THE SELECTION OF RATING & FORCE

Model	Rating	L
MDU-DFW	P1	*
	G1	*
	G3	*
	G5	*

NOTE : The Symbol " * " to represent the result is accepted

CERTIFICATE INFORMATION

Model Name	UL, cUL	ENEC
DFW-P1	0.1RA 125/250VAC μ T85 1E4	0.1A 125/250VAC μ T85 1E4
DFW-G1	3RA 24VDC μ T85 1E4	3A 24VDC μ T85 1E4
DFW-03	3RA 125/250VAC μ T85 1E4	3A 125/250VAC μ T85 1E4
DFW-G3	3RA 24VDC μ T85 1E4	3A 24VDC μ T85 1E4
DFW-05	5RA 125/250VAC μ T85 1E4	5A 125/250VAC μ T85 1E4
	3RA 24VDC μ T85 1E4	3A 24VDC μ T85 1E4

TERMINAL TYPES

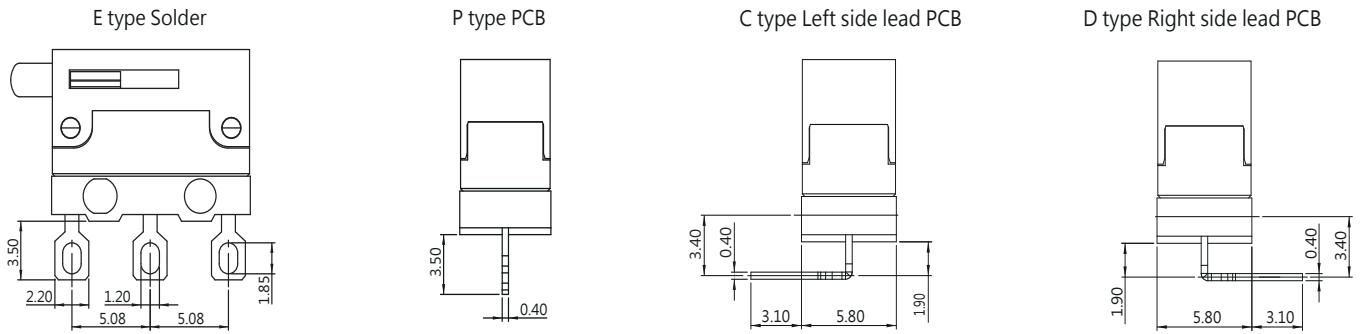

ORDERING INFORMATION

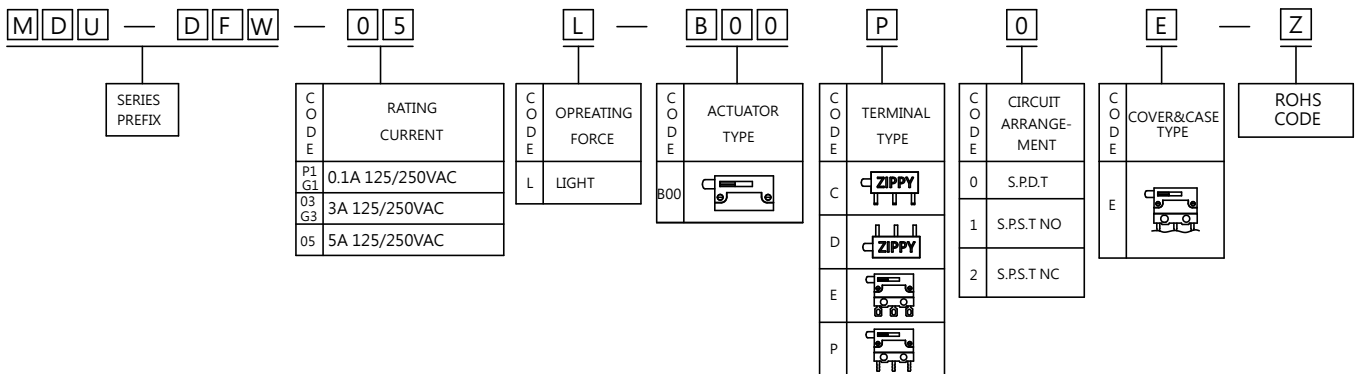

OPERATING CHARACTERISTICS

SWITCH TYPE	PART SUFFIX	OF Max (gf)	OP (mm)	PT Max (mm)	OT Min (mm)	MD Max (mm)	FP Max (mm)	RF Min (gf)	
MDU-DFW-□□ L-B00 □ -Z		L	130	11.8±0.5	0.7	2.0	0.4	12.5	20

CAUTIONS:

注意事項

1. To secure the switch, please use an M2 small screw on a flat surface and tighten with plane washers or spring washers to securely mount the Switch, using a maximum torque of 0.1 N•m.
若使用定位孔型式上蓋，請使用M2小型螺絲固定在平面上，並使用平墊圈或者彈性墊圈以便安全的鎖固開關，鎖固扭力請勿超過0.1 N•m。
2. Do not handle the switch in a way that may cause damage to the sealed rubber & switch sealing.
使用開關時，請勿損壞開關防水矽膠罩及開關防水膠。
3. Wires should not be dragged.
使用帶線型式時，請注意避免拉扯線材。
4. To ensure the best performance of the switch, when handling/installing the switch, please do not apply uneven pressure to the direction indicated by the arrow in Figure 1. Any uneven pressure or pressure direction other than the operating direction might be harmful or damage the switch performance.
為確保開關正常運作，安裝及取用開關時，請勿直接施加壓力在圖-1中箭頭所指示的方向。如圖所示，任何不對稱的壓力或作動方向以外的壓力都不適用在開關按柄上。
5. Do not exceed the end position (EP) and over travel (OT). This could cause operation failure.
圖示設計按壓位置，請勿超過開關下死點及超出行程，以避免開關失效。
6. Avoid applying any grease/oil and chemicals on the switch rubber.
請避免沾附任何油脂或者化學物質在開關的矽膠防水罩上。

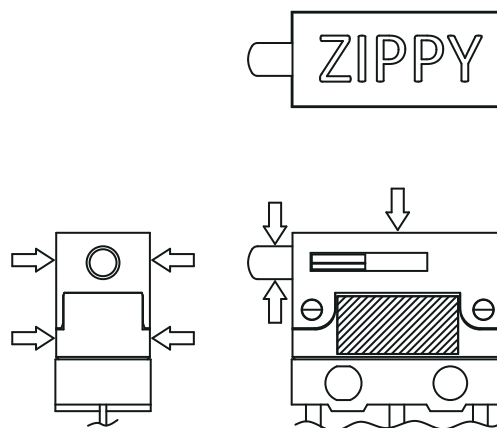

Figure-1 (圖-1)

WATER PROOF SWITCHES



MDU-DFW(IP67) SERIES

APPLICATIONS

Automotive (Operation system, Engine area Interior)
Air conditioner, communication, Electric tooth brush, toys

DIMENSIONS

Unless otherwise specified, a tolerance of $\pm 0.4\text{mm}$ applies to all dimensions.

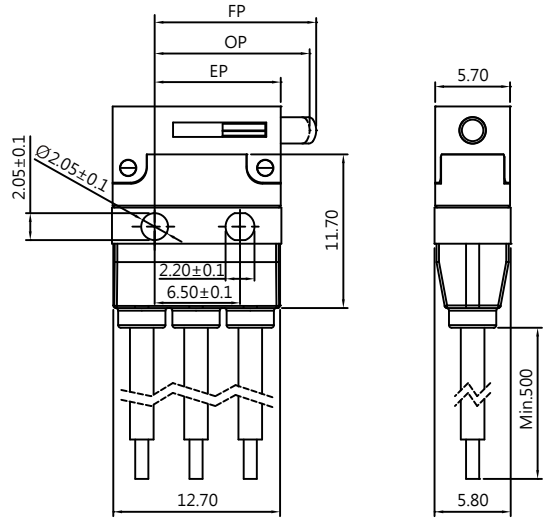

CERTIFICATE INFORMATION

Model Name	UL, cUL	ENEC
DFW-P1	0.1RA 125/250VAC μ T85 1E4	0.1A 125/250VAC μ T85 1E4
DFW-G1	3RA 24VDC μ T85 1E4	3A 24VDC μ T85 1E4
DFW-O3	3RA 125/250VAC μ T85 1E4	3A 125/250VAC μ T85 1E4
DFW-G3	3RA 24VDC μ T85 1E4	3A 24VDC μ T85 1E4
DFW-O5	5RA 125/250VAC μ T85 1E4 3RA 24VDC μ T85 1E4	5A 125/250VAC μ T85 1E4 3A 24VDC μ T85 1E4

※ For the specification, please refer to MDU-DFW SERIES. ※

ORDERING INFORMATION

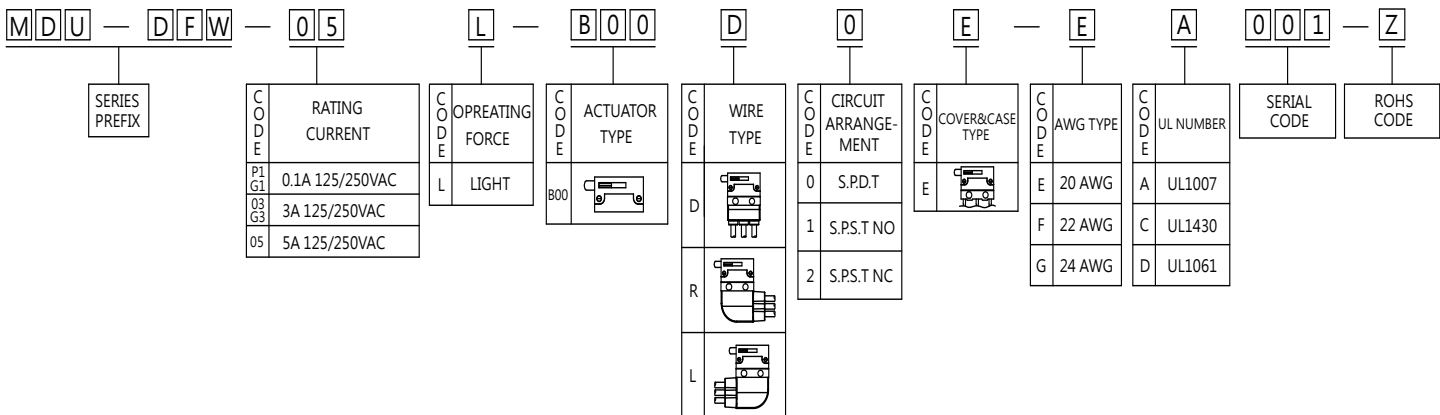

WATER PROOF SWITCHES

CAUTIONS:

注意事項

1. To secure the switch, please use an M2 small screw on a flat surface and tighten with plane washers or spring washers to securely mount the Switch, using a maximum torque of 0.1 N•m.
若使用定位孔型式上蓋，請使用M2小型螺絲固定在平面上，並使用平墊圈或者彈性墊圈以便安全的鎖固開關，鎖固扭力請勿超過0.1 N•m。
2. Do not handle the switch in a way that may cause damage to the sealed rubber & switch sealing.
使用開關時，請勿損壞開關防水矽膠罩及開關防水膠。
3. Wires should not be dragged.
使用帶線型式時，請注意避免拉扯線材。
4. To ensure the best performance of the switch, when handling/installing the switch, please do not apply uneven pressure to the direction indicated by the arrow in Figure 1. Any uneven pressure or pressure direction other than the operating direction might be harmful or damage the switch performance.
為確保開關正常運作，安裝及取用開關時，請勿直接施加壓力在圖-1中箭頭所指示的方向。如圖所示，任何不對稱的壓力或作動方向以外的壓力都不適用在開關按柄上。
5. Do not exceed the end position (EP) and over travel (OT). This could cause operation failure.
圖示設計按壓位置，請勿超過開關下死點及超出行程，以避免開關失效。
6. Avoid applying any grease/oil and chemicals on the switch rubber.
請避免沾附任何油脂或者化學物質在開關的矽膠防水罩上。

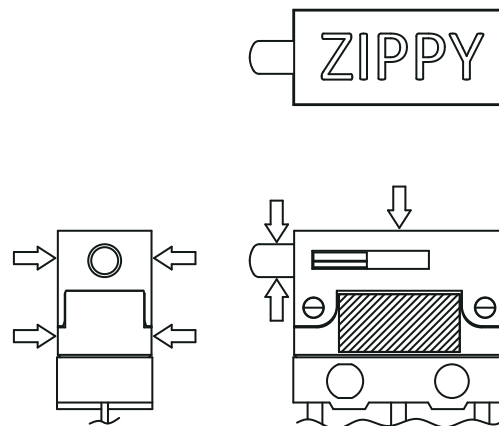
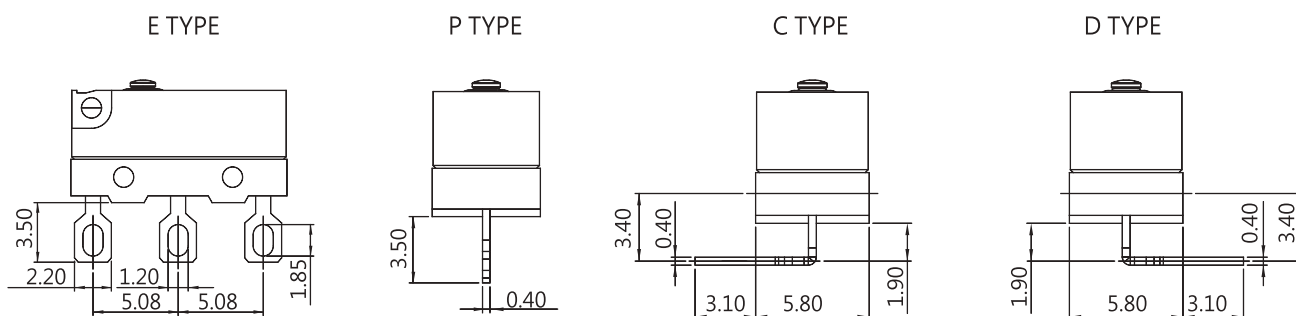

Figure-1 (圖-1)

TERMINAL TYPES



COVER TYPES

A type

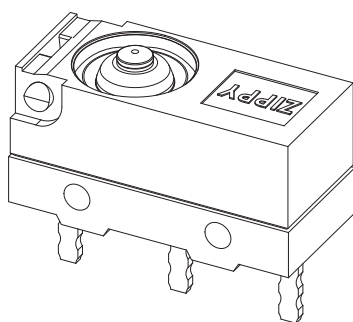

A type – Screw holes $\varnothing 1.2$ mm

E type

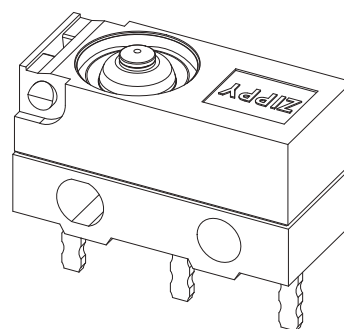

E type – Screw holes $\varnothing 2.05$ mm

ORDERING INFORMATION

D F W	0 5	S	B 0 1	P	0	A	Z
SERIES PREFIX	CODE RATING CURRENT	CODE OPERATING FORCE	CODE ACTUATOR TYPE	CODE TERMINAL TYPE	CODE CIRCUIT ARRANGEMENT	CODE COVER&CASE TYPE	ROHS CODE
	P1 0.1A G1 125/250VAC	S STANDARD L LIGHT	A00 A01 A02	C D E P	0 S.P.D.T 1 S.P.S.T NO 2 S.P.S.T NC	A E	
	03 3A G3 125/250VAC		B00 B01 B02				
	05 5A 125/250VAC						

OPERATING CHARACTERISTICS (Internal snap-fit lever)

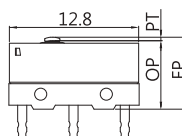
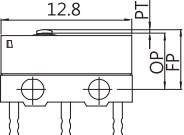
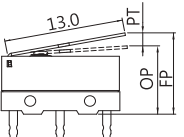
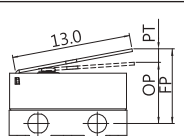
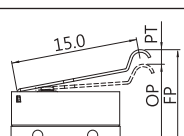
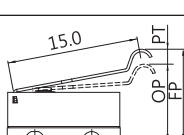
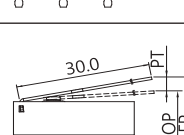
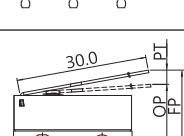
SWITCH TYPE	PART SUFFIX	OF Max. (gf)		OP (mm)	PT Max. (mm)	OT Min. (mm)	MD Max. (mm)	FP Max. (mm)	RF Min. (gf)
		L	S						
DFW- □□□ -A00 □ -Z		L	100	7.0 ± 0.2	0.5	0.2	0.12	7.5	21
		S	170						35
		L	100	5.9 ± 0.2	0.5	0.2	0.12	6.4	21
		S	170						35
DFW- □□□ -A01 □ -Z		L	32	8.2 ± 0.8	3.4	0.6	0.8	10.1	5
		S	56						8
		L	32	7.1 ± 0.8	3.4	0.6	0.8	9.0	5
		S	56						8
DFW- □□□ -A02 □ -Z		L	28	10.2 ± 0.8	3.5	0.7	0.92	14.2	5
		S	48						7
		L	28	9.1 ± 0.8	3.5	0.7	0.92	13.1	5
		S	48						7
DFW- □□□ -A09 □ -Z		L	22	9.5 ± 1.7	6.9	0.55	1.9	16.8	1
		S	24						3
		L	22	8.4 ± 1.7	6.9	0.55	1.9	15.7	1
		S	24						3

OPERATING CHARACTERISTICS (External snap-fit lever)

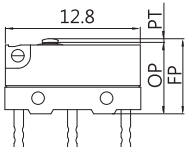
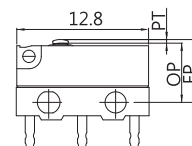
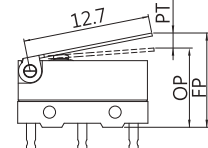
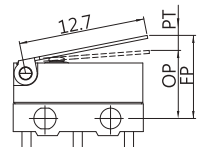
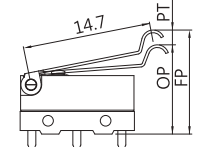
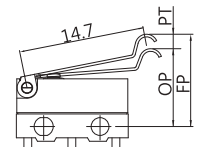
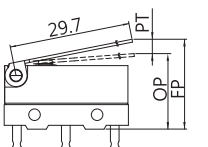
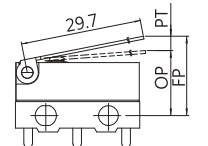
SWITCH TYPE	PART SUFFIX	OF Max. (gf)		OP (mm)	PT Max. (mm)	OT Min. (mm)	MD Max. (mm)	FP Max. (mm)	RF Min. (gf)
		L	S						
DFW- □□□ -B00 □ -Z		L	100	7.0 ± 0.2	0.5	0.2	0.12	7.5	21
		S	170						35
		L	100	5.9 ± 0.2	0.5	0.2	0.12	6.4	21
		S	170						35
DFW- □□□ -B01 □ -Z		L	32	8.2 ± 0.8	3.4	0.6	0.8	10.1	5
		S	56						8
		L	32	7.1 ± 0.8	3.4	0.6	0.8	9.0	5
		S	56						8
DFW- □□□ -B02 □ -Z		L	28	10.2 ± 0.8	3.5	0.7	0.92	14.2	5
		S	48						7
		L	28	9.1 ± 0.8	3.5	0.7	0.92	13.1	5
		S	48						7
DFW- □□□ -B09 □ -Z		L	22	9.5 ± 1.7	6.9	0.55	1.9	16.8	1
		S	24						3
		L	22	8.4 ± 1.7	6.9	0.55	1.9	15.7	1
		S	24						3

CAUTIONS:

注意事項

1. To secure the switch, please use an M2 small screw on a flat surface and tighten with plane washers or spring washers to securely mount the Switch, using a maximum torque of 0.1 N•m.
若使用定位孔型式上蓋，請使用M2小型螺絲固定在平面上，並使用平墊圈或者彈性墊圈以便安全的鎖固開關，鎖固扭力請勿超過0.1N•m。
2. Do not handle the switch in a way that may cause damage to the sealed rubber & switch sealing.
使用開關時，請勿損壞開關防水矽膠罩及開關防水膠。
3. To ensure the best performance of the switch, when handling/installing the switch, please do not apply uneven pressure to the direction indicated by the arrow in Figure 1. Any uneven pressure or pressure direction other than the operating direction might be harmful or damage the switch performance.
為確保開關正常運作，安裝及取用開關時，請勿直接施加壓力在圖-1中箭頭所指示的方向。如圖所示，任何不對稱的壓力或作動方向以外的壓力都不適用在開關按柄上。
4. Do not exceed the end position (EP) and over travel (OT). This could cause operation failure.
圖示設計按壓位置，請勿超過開關下死點及超出行程，以避免開關失效。
5. Avoid applying any grease/oil and chemicals on the switch rubber.
請避免沾附任何油脂或者化學物質在開關的矽膠防水罩上。

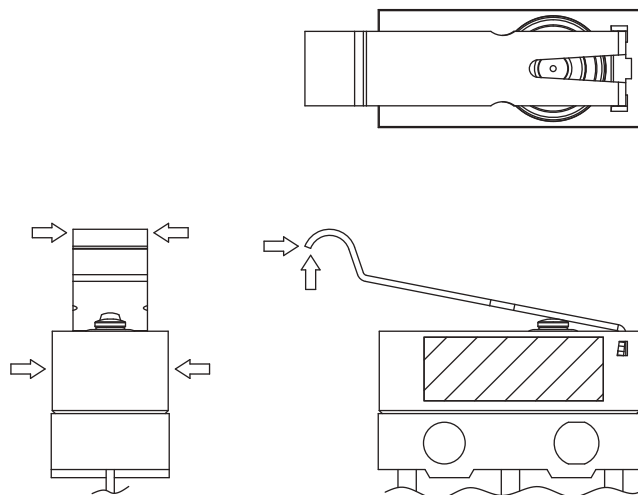

Figure-1 (圖-1)

WATER PROOF SWITCHES



DFW (IP67) SERIES

DIMENSIONS

Unless otherwise specified, a tolerance of $\pm 0.4\text{mm}$ applies to all dimensions.

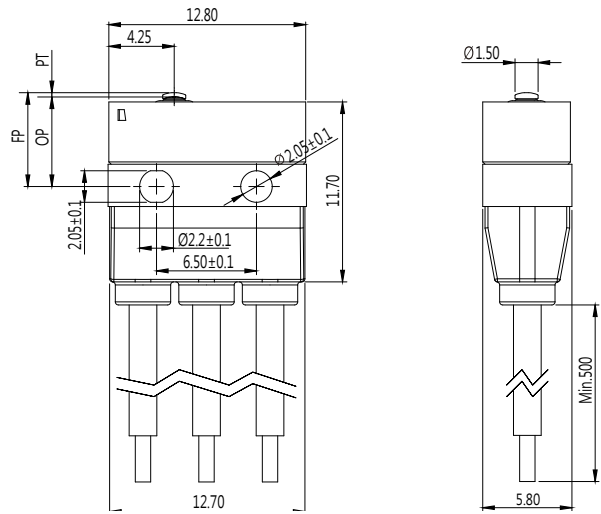

APPLICATIONS

Automotive (Operation system, Engine area Interior)
Air conditioner, communication, Electric tooth brush, toys

※ For the specification, please refer to DFW SERIES. ※

CERTIFICATE INFORMATION

Model Name	UL, cUL	ENEC
DFW-P1	0.1RA 125/250VAC μ T85 1E4	0.1A 125/250VAC μ T85 1E4
DFW-G1	3RA 24VDC μ T85 1E4	3A 24VDC μ T85 1E4
DFW-03	3RA 125/250VAC μ T85 1E4	3A 125/250VAC μ T85 1E4
DFW-G3	3RA 24VDC μ T85 1E4	3A 24VDC μ T85 1E4
DFW-05	5RA 125/250VAC μ T85 1E4	5A 125/250VAC μ T85 1E4
	3RA 24VDC μ T85 1E4	3A 24VDC μ T85 1E4

ORDERING INFORMATION

SERIES PREFIX	RATING CURRENT	OPERATING FORCE	ACTUATOR TYPE	WIRE TYPE	CIRCUIT ARRANGEMENT	CASE & COVER TYPE	AWG TYPE	UL NUMBER	SERIAL CODE	ROHS CODE
DFW	05	S	B01	D	0	A	E	A	001	Z
P1	0.1A	S	A00	D	0	A	E	A	001	Z
G1	125/250VAC	L	A01	R	1	E	F	C		
03	3A		A02	L	2		G	D		
G3	125/250VAC									
05	5A									
	125/250VAC									
			B00							
			B01							
			B02							

OPERATING CHARACTERISTICS (Internal snap-fit lever)

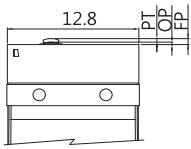
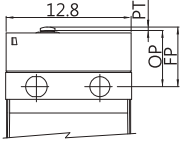
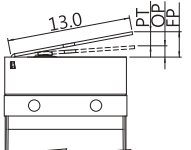
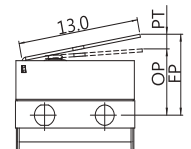
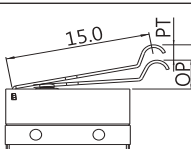
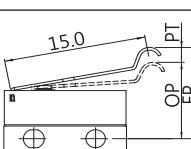
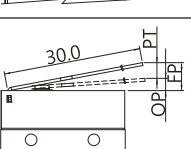
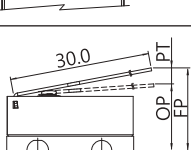
SWITCH TYPE	PART SUFFIX	OF Max. (gf)		OP (mm)	PT Max. (mm)	OT Min. (mm)	MD Max. (mm)	FP Max. (mm)	RF Min. (gf)
		L	S						
DFW- □□□ -A00 □ -Z		L	100	0.4 ± 0.2	0.5	0.2	0.12	0.9	21
		S	170						35
		L	100	5.9 ± 0.2	0.5	0.2	0.12	6.4	21
		S	170						35
DFW- □□□ -A01 □ -Z		L	32	1.6 ± 0.8	3.4	0.6	0.8	3.5	5
		S	56						8
		L	32	7.1 ± 0.8	3.4	0.6	0.8	9.0	5
		S	56						8
DFW- □□□ -A02 □ -Z		L	28	3.6 ± 0.8	3.5	0.7	0.92	7.6	5
		S	48						7
		L	28	9.1 ± 0.8	3.5	0.7	0.92	13.1	5
		S	48						7
DFW- □□□ -A09 □ -Z		L	22	2.9 ± 1.7	6.9	0.55	1.9	10.2	1
		S	24						3
		L	22	8.4 ± 1.7	6.9	0.55	1.9	15.7	1
		S	24						3

OPERATING CHARACTERISTICS (External snap-fit lever)

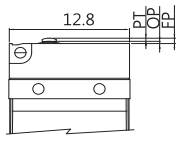
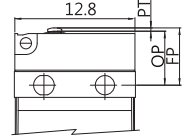
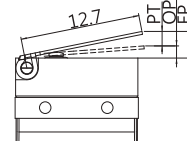
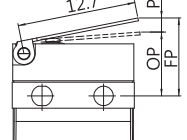
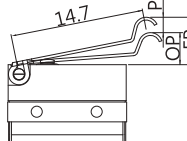
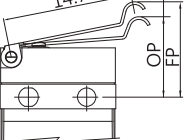
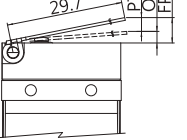
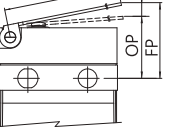
SWITCH TYPE	PART SUFFIX	OF Max. (gf)		OP (mm)	PT Max. (mm)	OT Min. (mm)	MD Max. (mm)	FP Max. (mm)	RF Min. (gf)
		L	S						
DFW- □□□ -B00 □ -Z		L	100	0.4 ± 0.2	0.5	0.2	0.12	0.9	21
		S	170						35
		L	100	5.9 ± 0.2	0.5	0.2	0.12	6.4	21
		S	170						35
DFW- □□□ -B01 □ -Z		L	32	1.6 ± 0.8	3.4	0.6	0.8	3.5	5
		S	56						8
		L	32	7.1 ± 0.8	3.4	0.6	0.8	9.0	5
		S	56						8
DFW- □□□ -B02 □ -Z		L	28	3.6 ± 0.8	3.5	0.7	0.92	7.6	5
		S	48						7
		L	28	9.1 ± 0.8	3.5	0.7	0.92	13.1	5
		S	48						7
DFW- □□□ -B09 □ -Z		L	22	2.9 ± 1.7	6.9	0.55	1.9	10.2	1
		S	24						3
		L	22	8.4 ± 1.7	6.9	0.55	1.9	15.7	1
		S	24						3

CAUTIONS:

注意事項

1. To secure the switch, please use an M2 small screw on a flat surface and tighten with plane washers or spring washers to securely mount the Switch, using a maximum torque of 0.1 N•m.
若使用定位孔型式上蓋，請使用M2小型螺絲固定在平面上，並使用平墊圈或者彈性墊圈以便安全的鎖固開關，鎖固扭力請勿超過0.1 N•m。
2. Do not handle the switch in a way that may cause damage to the sealed rubber & switch sealing.
使用開關時，請勿損壞開關防水矽膠罩及開關防水膠。
3. Wires should not be dragged.
使用帶線型式時，請注意避免拉扯線材。
4. To ensure the best performance of the switch, when handling/installing the switch, please do not apply uneven pressure to the direction indicated by the arrow in Figure 1. Any uneven pressure or pressure direction other than the operating direction might be harmful or damage the switch performance.
為確保開關正常運作，安裝及取用開關時，請勿直接施加壓力在圖-1中箭頭所指示的方向。如圖所示，任何不對稱的壓力或作動方向以外的壓力都不適用在開關按柄上。
5. Do not exceed the end position (EP) and over travel (OT). This could cause operation failure.
圖示設計按壓位置，請勿超過開關下死點及超出行程，以避免開關失效。
6. Avoid applying any grease/oil and chemicals on the switch rubber.
請避免沾附任何油脂或者化學物質在開關的矽膠防水罩上。

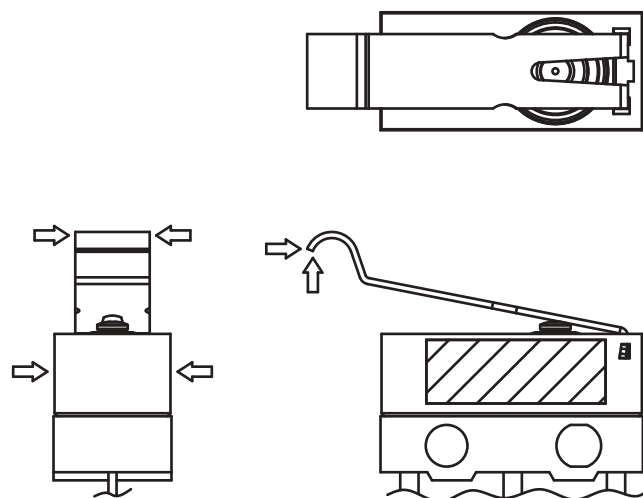

Figure-1 (圖-1)

WATER PROOF SWITCHES



DIMENSIONS

Unless otherwise specified, a tolerance of $\pm 0.4\text{mm}$ applies to all dimensions.

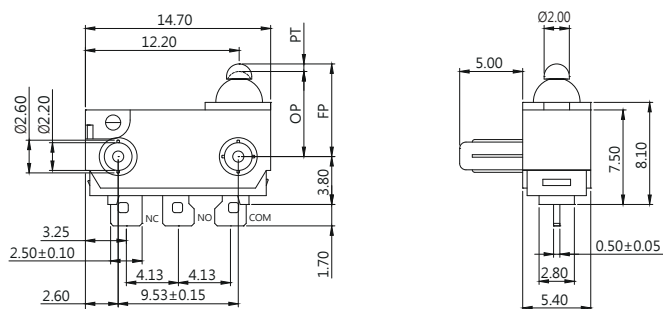

DW SERIES

SPECIFICATIONS

Contact Resistance(initial)

Max. 100 m Ω

Measured by ohm meter - open voltage <1 VDC, driver current -100 mA

Insulation Resistance (at 500VDC/minute)

Min. 100M Ω

Dielectric Strength

Min. 150VAC(50-60HZ)/minute between Live parts.

Min. 500VAC(50-60HZ)/minute between Live parts and dead metal parts

Operating Temperature Range

-40°C to 85°C (with no icing)

Vibration

10~55Hz, displacement 0.75 mm (p-p)

Electrical Service Life

10mA - Min. 500,000 operations

3A - Min. 6,000 operations

Electrical Operating Frequency

10~30 operations per minute

Mechanical Service Life

Min. 500,000 operations

Mechanical Operating Frequency

120 operations per minute

Operating application of the switch

Set the switch pushing distance from 60% to 90% of the specified OT value

Degree of Protection

IP67 (excluding the terminals on terminal models)

※ For IP67 option, please contact your ZIPPY sales representative.

CONTACT CONFIGURATION

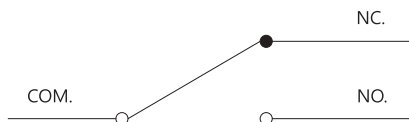

MOUNTING HOLES FOR PCB TERMINAL

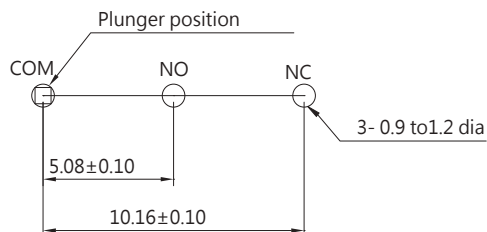

PILLAR PITCH

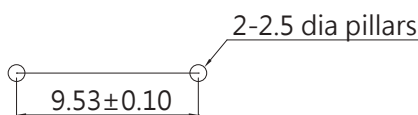

APPLICATIONS

Automotive (Seat Belt, Door Latch, Engine Hood, Door Trunk), Air Conditioner, Communication, Security System, Electric Tooth Brush, Toy

CERTIFICATE INFORMATION

Model Name	UL, cUL	ENEC
DW-N2S	10 mA 12 VDC (Temp65°C), Min. 10,000 operations	10 mA 12 VDC, μ T55 5E5
DW-N3S	3 A 12 VDC (Temp65°C) Min. 100,000 operations 3 A 125 VAC (Temp65°C) Min. 6,000 operations	3 A 12 VDC, μ T55 1E5

TERMINAL TYPES (THE thickness of each terminal is 0.5mm)

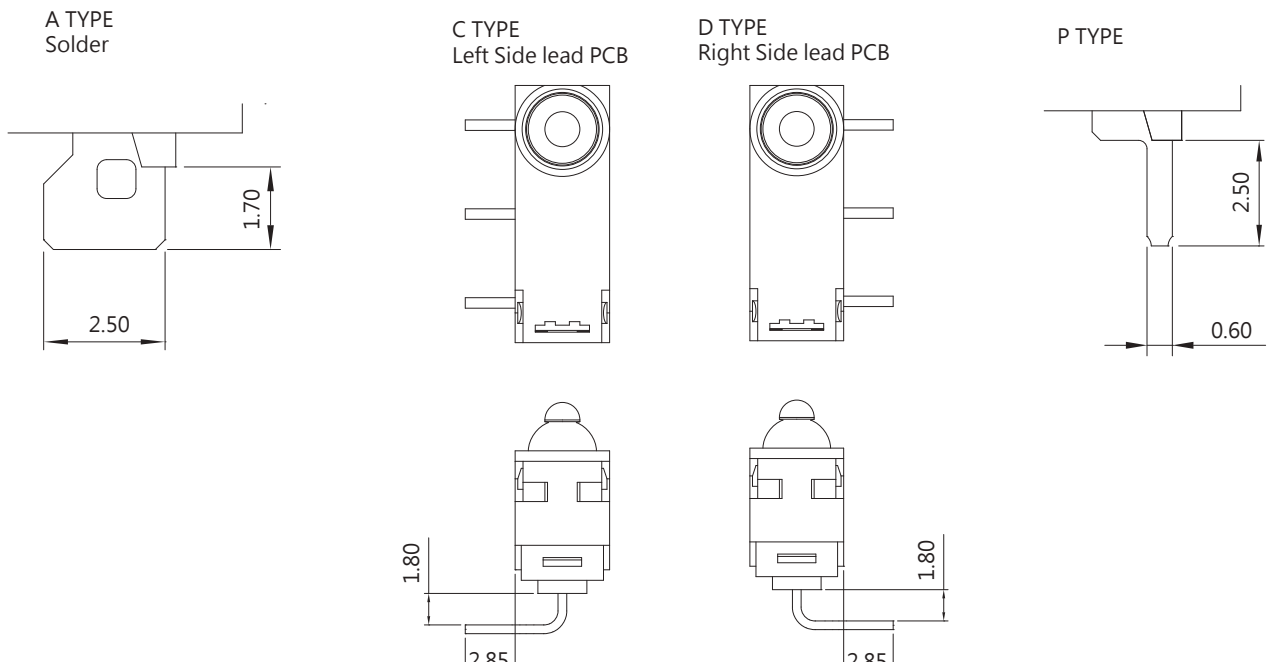

COVER TYPES (PILLAR & TRAVEL TYPES)

LONG TRAVEL

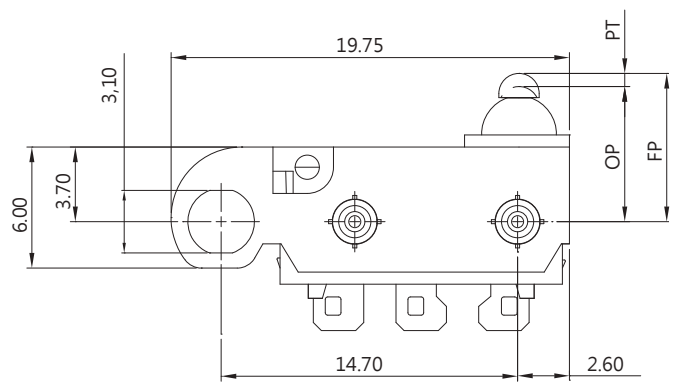
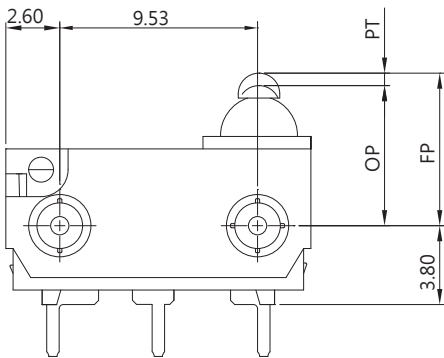
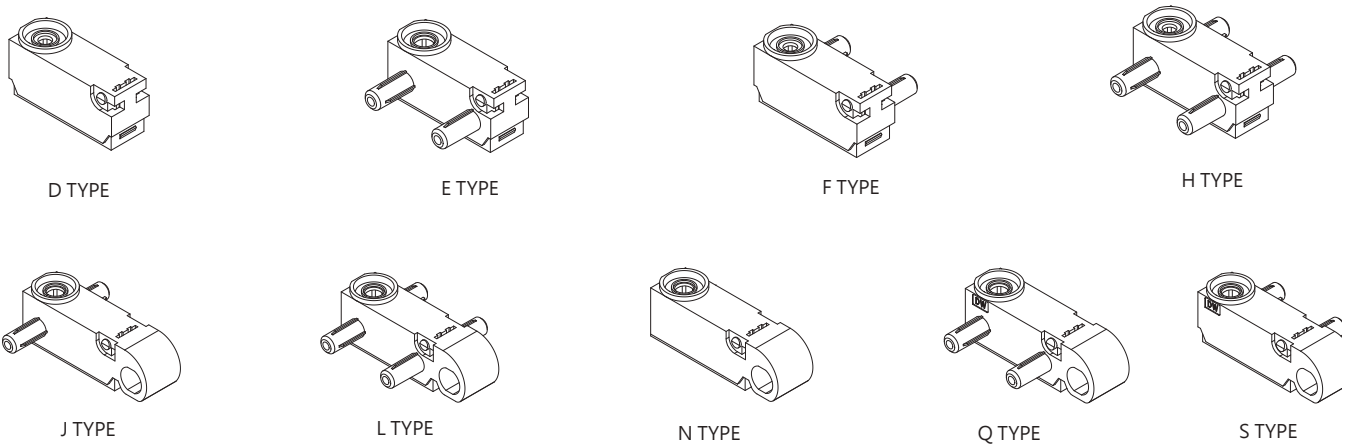

ORDERING INFORMATION

D	W	N	2	S	0	1	A	0	A	0	A	Z		
SERIES PREFIX	CODE	RATING CURRENT	CODE	OPERATING FORCE	CODE	ACTUATOR TYPE	CODE	TERMINAL TYPE	CODE	CIRCUIT ARRANGEMENT	CODE	PILLAR & TRAVEL TYPE	SERIAL CODE	ROHS CODE
		10mA 12VDC Contact Plated Gold and Terminal Plated Sliver	S	STANDARD	00		A		0	S.P.D.T	D			
	N2				01		C		1	S.P.S.T.NO	E			
	N3	3A 125VAC			04		D		2	S.P.S.T.NC	F			
							P				H			
											J			
											L			
											N			
											Q			
											S			

DIMENSIONS							
CODE	L1	H	ØA	ØB	ØC	ØD	P
	5.0	3.7	2.2	2.6	2.2	2.6	9.53
A	2.0	3.7	2.2	2.6	2.2	2.6	9.53
B	3.5	3.7	2.2	2.6	2.2	2.6	9.53
C	2.8	3.75	2.7	3.1 (THREE RIBS)	2.2	2.6	9.53
D	4.0	3.7	2.2	2.6	2.2	2.6	9.53
E	0.9	3.7	2.2	N/A	2.2	N/A	9.53
F	1.8	3.7	2.5	N/A	2.5	N/A	9.53
G	5.0	3.7	2.4	2.8	2.4	2.8	8.0

OPERATING CHARACTERISTICS

SWITCH TYPE	PART SUFFIX	OF Max (gf)	OP (mm)	PT Max (mm)	OT Min (mm)	MD Max (mm)	FP Max (mm)	RF Min (gf)
DW- □□ S-00 □□ -Z		S	130	0.8	0.8	0.3	3.65	35
							7.35	
DW- □□ S-01 □□ -Z		S	195	3.85	1.35	0.5	7.0	55
							10.7	
DW- □□ S-04 □□ -Z		S	160	4.8	1.65	0.7	10.1	45
							13.8	

CAUTIONS:

注意事項

1. To secure the switch, please use an M3 small screw on a flat surface and tighten with plane washers or spring washers to securely mount the Switch, using a maximum torque of 0.29 N•m.
若使用定位孔型式上蓋，請使用M3小型螺絲固定在平面上，並使用平墊圈或者彈性墊圈以便安全的鎖固開關，鎖固扭力請勿超過0.29 N•m.
2. Do not handle the switch in a way that may cause damage to the sealed rubber & switch sealing.
使用開關時，請勿損壞開關防水矽膠罩及開關防水膠。
3. To ensure the best performance of the switch, when handling/installing the switch, please do not apply uneven pressure to the direction indicated by the arrow in Figure 1. Any uneven pressure or pressure direction other than the operating direction might be harmful or damage the switch performance.
為確保開關正常運作，安裝及取用開關時，請勿直接施加壓力在圖-1中箭頭所指示的方向。如圖所示，任何不對稱的壓力或作動方向以外的壓力都不適用在開關按柄上。
4. Do not exceed the end position (EP) and over travel (OT). This could cause operation failure. (Figure-2)
圖示設計按壓位置，請勿超過開關下死點及超出行程，以避免開關失效。(圖2)
5. Avoid applying any grease/oil and chemicals on the switch rubber.
請避免沾附任何油脂或者化學物質在開關的矽膠防水罩上。

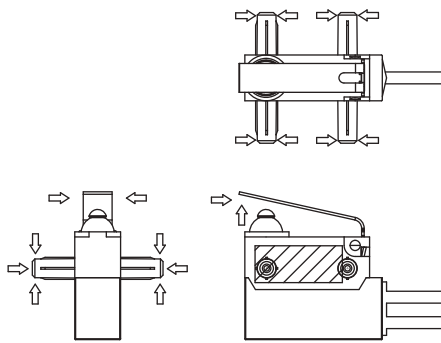

Figure-1

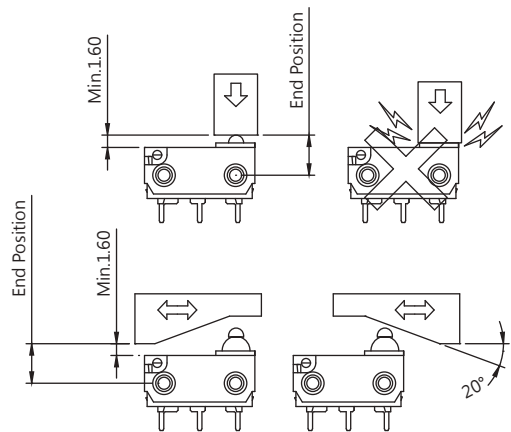

Figure-2

WATER PROOF SWITCHES



DW (IP67)SERIES

DIMENSIONS

Unless otherwise specified, a tolerance of $\pm 0.4\text{mm}$ applies to all dimensions.

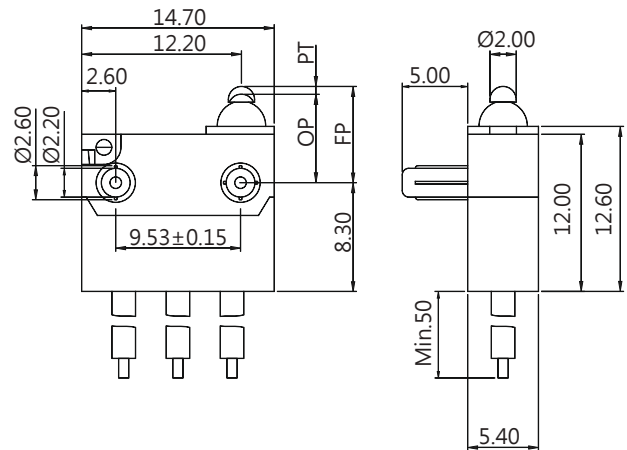

APPLICATIONS

Automotive (Seat Belt, Door Latch, Engine Hood, Door Trunk), Air Conditioner, Communication, Security System, Electric Tooth Brush, Toy

CERTIFICATE INFORMATION

Model Name	UL, cUL	ENEC
DW-N2S	10 mA 12 VDC (Temp : 65°C) Min. 10,000 operations	10mA 12VDC, μ T55 5E5
DW-N3S	3 A 12 VDC (Temp:65°C) Min. 100,000 operations 3A 125 VAC (Temp:65°C) Min. 6,000 operations	3A 12VDC, μ T55 1E5

※ For the specification, please refer to DW SERIES. ※

ORDERING INFORMATION

DW	-	N2	-	S	-	01	-	A	-	0	-	E	-	A	-	001A	-	Z	
SERIES PREFIX	CODE	RATING CURRENT	CODE	OPERATING FORCE	CODE	ACTUATOR TYPE	CODE	PILLAR & TRAVEL TYPE	CODE	CIRCUIT ARRANGEMENT	CODE	AWG TYPE	CODE	UL NUMBER	SERIAL CODE	ROHS CODE	DIMENSIONS		
		10mA 12VDC Contact Plated N2 Gold and Terminal Plated Sliver	S	STANDARD	00		D		0	S.P.D.T	E	20	A	UL 1007					
		N3 3A 12VDC			01		E		1	S.P.S.T.NO	F	22	C	UL 1430					
					04		F		2	S.P.S.T.NC	G	24	D	UL 1061					
							H												
							J												
							L												
							N												
							Q												
							S												

CODE	L1	H	ØA	ØB	ØC	ØD	P
	5.0	3.7	2.2	2.6	2.2	2.6	9.53
A	2.0	3.7	2.2	2.6	2.2	2.6	9.53
B	3.5	3.7	2.2	2.6	2.2	2.6	9.53
C	2.8	3.75	2.7	3.1 (THREE RIBS)	2.2	2.6	9.53
D	4.0	3.7	2.2	2.6	2.2	2.6	9.53
E	0.9	3.7	2.2	N/A	2.2	N/A	9.53
F	1.8	3.7	2.5	N/A	2.5	N/A	9.53
G	5.0	3.7	2.4	2.8	2.4	2.8	8.0

Note 1: Safety leads wire: Min. 50mm (20~26AWG)

CAUTIONS:

注意事項

1. To secure the switch, please use an M3 small screw on a flat surface and tighten with plane washers or spring washers to securely mount the Switch, using a maximum torque of 0.29 N•m.
若使用定位孔型式上蓋，請使用M3小型螺絲固定在平面上，並使用平墊圈或者彈性墊圈以便安全的鎖固開關，鎖固扭力請勿超過0.29 N•m.
2. Do not handle the switch in a way that may cause damage to the sealed rubber & switch sealing.
使用開關時，請勿損壞開關防水矽膠罩及開關防水膠。
3. Wires should not be dragged.
使用帶線型式時，請注意避免拉扯線材。
4. To ensure the best performance of the switch, when handling/installing the switch, please do not apply uneven pressure to the direction indicated by the arrow in Figure 1. Any uneven pressure or pressure direction other than the operating direction might be harmful or damage the switch performance.
為確保開關正常運作，安裝及取用開關時，請勿直接施加壓力在圖-1中箭頭所指示的方向。如圖所示，任何不對稱的壓力或作動方向以外的壓力都不適用在開關按柄上。
5. Do not exceed the end position (EP) and over travel (OT). This could cause operation failure. (Figure-2)
圖示設計按壓位置，請勿超過開關下死點及超出行程，以避免開關失效。(圖2)
6. Avoid applying any grease/oil and chemicals on the switch rubber.
請避免沾附任何油脂或者化學物質在開關的矽膠防水罩上。

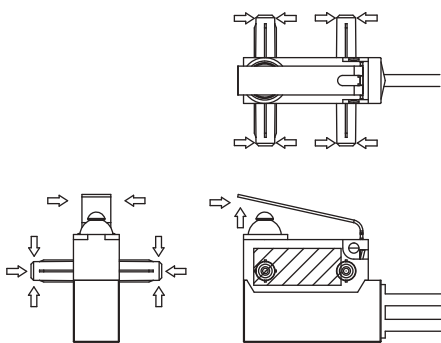

Figure-1

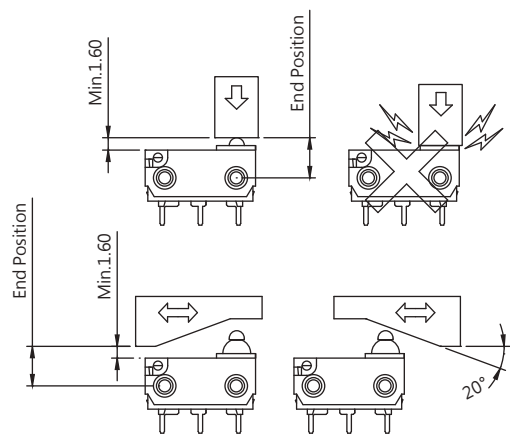

Figure-2

WATER PROOF SWITCHES



DIMENSIONS

Unless otherwise specified, a tolerance of $\pm 0.4\text{mm}$ applies to all dimensions.

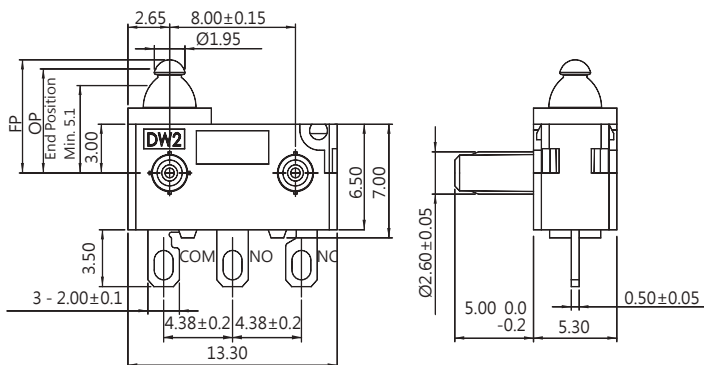

DW2 SERIES

SPECIFICATIONS

Contact Resistance (initial)

Max. 100mΩ

(Measured by ohm meter-Open Voltage<1VDC,Driver current-100mA)

Insulation Resistance (at 500VDC/minute)

Min. 100MΩ

Dielectric Strength

Min. 500VAC(50-60HZ)/minute between Live parts.

Min. 1500VAC(50-60HZ)/minute between Live parts and dead metal parts

Operating Temperature Range

-40°C to 85°C (with no icing)

Vibration

10~55Hz, displacement 0.75 mm (p-p)

Electrical Service Life

0.1A - Min. 100,000 operations

3A - Min. 10,000 operations

Electrical Operating Frequency

10~30 operations per minute

Mechanical Service Life

Min. 1,000,000 operations

Mechanical Operating Frequency

120 operations per minute

Operating application of the switch

Set the switch pushing distance from 60% to 90% of the specified OT value

Degree of Protection

IP67 (excluding the terminals on terminal models)

※ For IP67 option, please contact your ZIPPY sales representative.

APPLICATIONS

Automotive (Seat, Door Latch, Engine Hood, Door Truck),

Air Conditioner, Communication, Security System,

Electric tooth brush, Toy

CONTACT CONFIGURATION

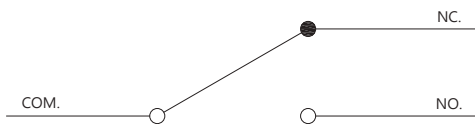

PILLAR PITCH

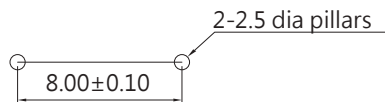

MOUNTING HOLES FOR PCB TERMINAL

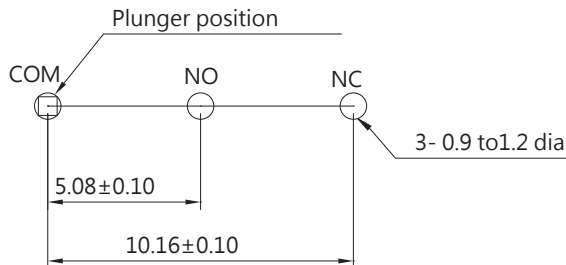

CERTIFICATE INFORMATION

Model Name	UL, cUL	ENEC
DW2-03	0.1RA 3RA 12VDC μ T55 1E5 3RA 24VDC μ T55 5E4 0.1RA 3RA 125/250VAC μ T55 1E4	0.1A 3A 12VDC μ T55 1E5 3A 24VDC μ T55 5E4 0.1A 3A 125/250VAC μ T55 1E4
DW2-G3	0.1RA 3RA 12VDC μ T55 1E5 3RA 24VDC μ T55 5E4 0.1RA 3RA 125/250VAC μ T55 1E4	0.1A 3A 12VDC μ T55 1E5 3A 24VDC μ T55 5E4 0.1A 3A 125/250VAC μ T55 1E4

COVER TYPES (PILLAR & TRAVEL TYPES)

A TYPE

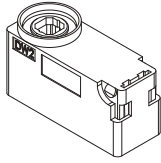

B TYPE

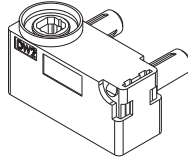

C TYPE

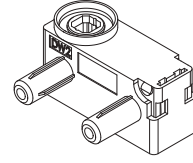

D TYPE

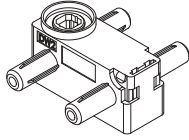

E TYPE

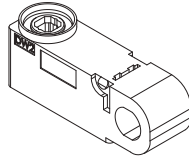

F TYPE

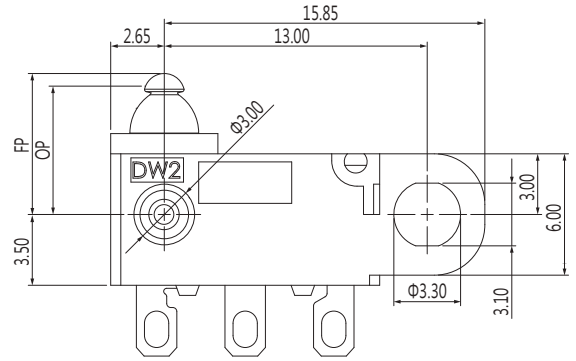
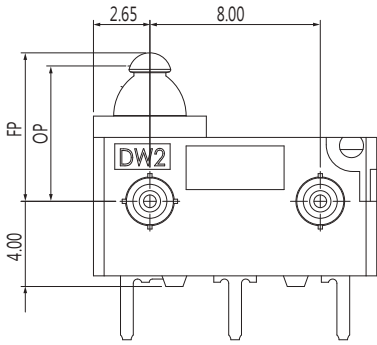
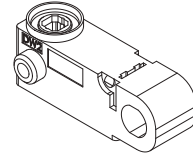

ORDERING INFORMATION



SERIES PREFIX

CODE	RATING CURRENT
G3	3A 125/250VAC (Contact Plated Gold)
03	3A 125/250VAC

CODE	OPERATING FORCE
S	STANDARD
H	HEAVY

CODE	ACTUATOR TYPE
00	
01	
A01	

CODE	TERMINAL TYPE
A	
C	
D	
P	

CODE	CIRCUIT ARRANGEMENT
0	S.P.D.T
1	S.P.S.T.NO
2	S.P.S.T.NC

CODE	PILLAR TYPE
A	
B	
C	
D	

PILLAR TYPE ROHS CODE

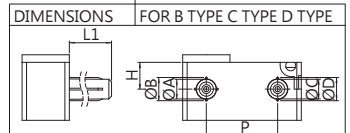

CODE	L1	H	ØA	ØB	ØC	ØD	P
	5.0	3.0	2.2	2.6	2.2	2.6	8.0
A	2.0	3.0	2.2	2.6	2.2	2.6	8.0
B	4.0	3.0	2.2	2.6	2.2	2.6	8.0
C	0.7	3.0	2.5	N/A	2.5	N/A	8.0

CODE	PILLAR TYPE
E	
F	

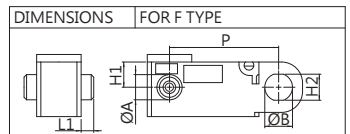

CODE	L1	H1	H2	ØA	ØB	P
	1.5	3.0	3.1	3.0	3.3	13.0

TERMINAL TYPES (THE thickness of each terminal is 0.5mm)

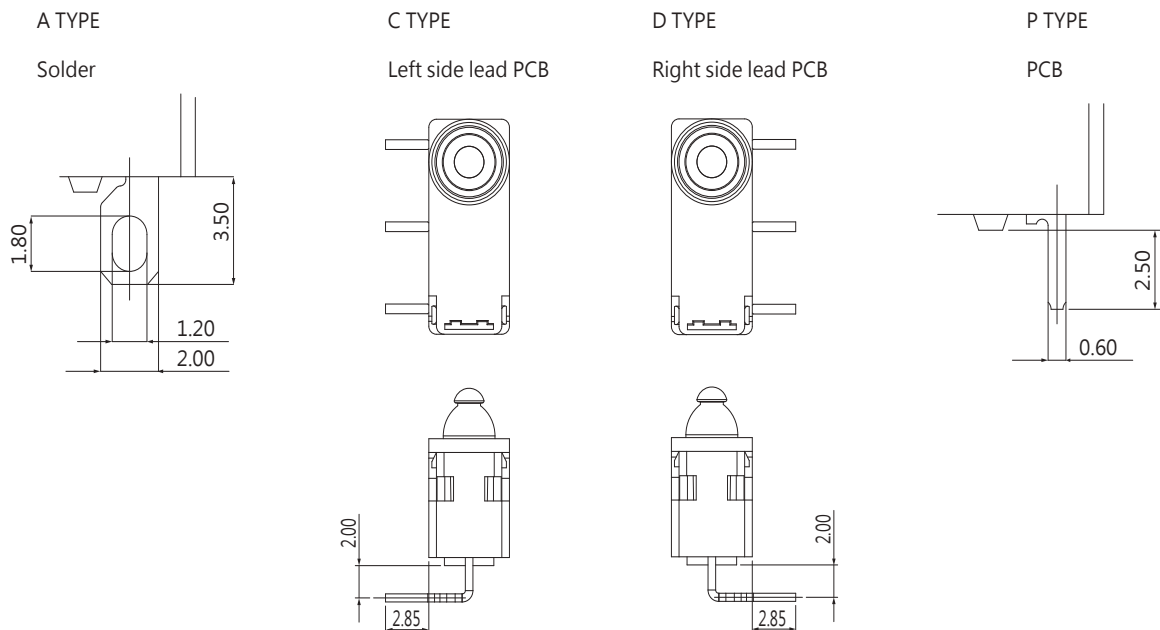

OPERATING CHARACTERISTICS

SWITCH TYPE	PART SUFFIX	OF		OP (mm)	EP Min (mm)	OT Min (mm)	MD Max (mm)	FP Max (mm)	RF Min (gf)
		Max (gf)							
DW2- □□□ -00 □□ -Z		S	95	10.4±0.2	9.1	1.1	0.25	11.2	10
		H	150						20
		S	95	6.4±0.2	5.1			10	
		H	150					20	
DW2- □□□ -01 □□ -Z		S	95	11.5±0.5	10	1.0	0.5	12.8	7
		H	150						13
		S	95	7.5±0.5	6			7	
		H	150					13	
DW2- □□□ -A01 □□ -Z		S	183	11.4±0.5	9.8	1.1	0.5	13.3	20
		H	220						38
		S	183	7.4±0.5	5.8			20	
		H	220					38	

CAUTIONS:

注意事項

1. To secure the switch, please use an M3 small screw on a flat surface and tighten with plane washers or spring washers to securely mount the Switch, using a maximum torque of 0.29 N•m.
若使用定位孔型式上蓋，請使用M3小型螺絲固定在平面上，並使用平墊圈或者彈性墊圈以便安全的鎖固開關，鎖固扭力請勿超過0.29 N•m.
2. Do not handle the switch in a way that may cause damage to the sealed rubber & switch sealing.
使用開關時，請勿損壞開關防水矽膠罩及開關防水膠。
3. To ensure the best performance of the switch, when handling/installing the switch, please do not apply uneven pressure to the direction indicated by the arrow in Figure 1. Any uneven pressure or pressure direction other than the operating direction might be harmful or damage the switch performance.
為確保開關正常運作，安裝及取用開關時，請勿直接施加壓力在圖-1中箭頭所指示的方向。如圖所示，任何不對稱的壓力或作動方向以外的壓力都不適用在開關按柄上。
4. Do not exceed the end position (EP) and over travel (OT). This could cause operation failure. (Figure-2)
圖示設計按壓位置，請勿超過開關下死點及超出行程，以避免開關失效。(圖2)
5. Avoid applying any grease/oil and chemicals on the switch rubber.
請避免沾附任何油脂或者化學物質在開關的矽膠防水罩上。

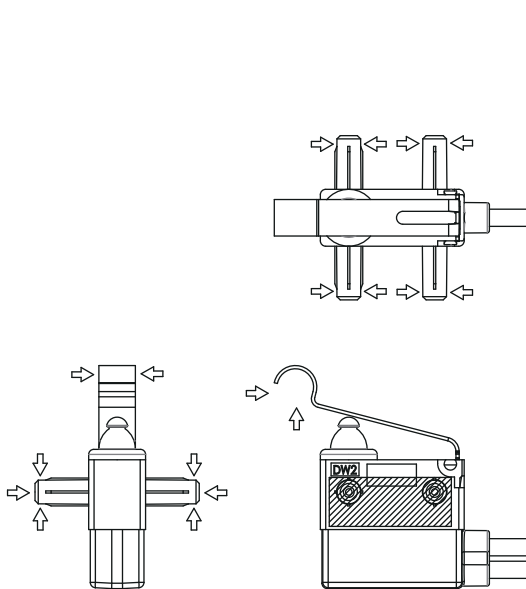

Figure-1

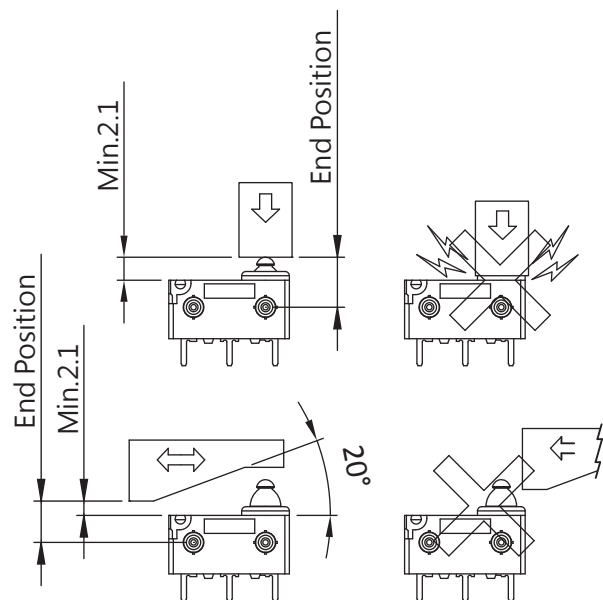

Figure-2

WATER PROOF SWITCHES



DIMENSIONS

Unless otherwise specified, a tolerance of $\pm 0.4\text{mm}$ applies to all dimensions.

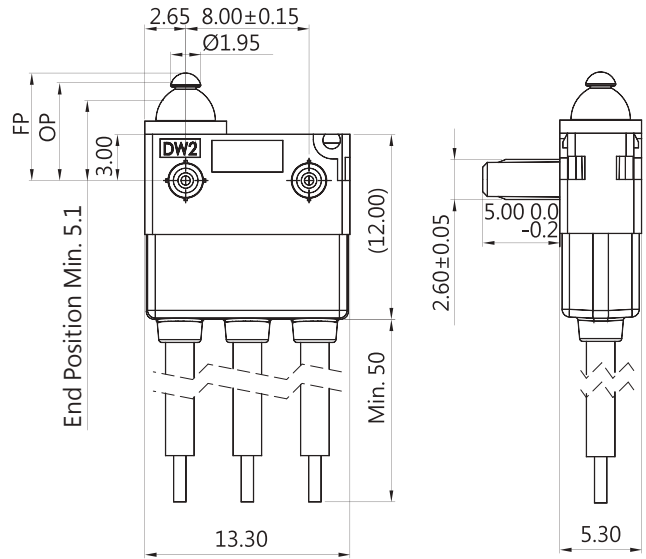

DW2 (IP67) SERIES

APPLICATIONS

Automotive (Seat, Door Latch, Engine Hood, Door Truck),
Air Conditioner, Communication, Security System,
Electric tooth brush, Toy

CERTIFICATE INFORMATION

Model Name	UL, cUL	ENEC
DW2-03	0.1RA 3RA 12VDC μ T55 1E5	0.1A 3A 12VDC μ T55 1E5
	3RA 24VDC μ T55 5E4	3A 24VDC μ T55 5E4
	0.1A 3RA 125/250VAC μ T55 1E4	0.1A 3A 125/250VAC μ T55 1E4
DW2-G3	0.1RA 3RA 12VDC μ T55 1E5	0.1A 3A 12VDC μ T55 1E5
	3RA 24VDC μ T55 5E4	3A 24VDC μ T55 5E4
	0.1RA 3RA 125/250VAC μ T55 1E4	0.1A 3A 125/250VAC μ T55 1E4

※ For the specification, please refer to DW2 SERIES. ※

ORDERING INFORMATION

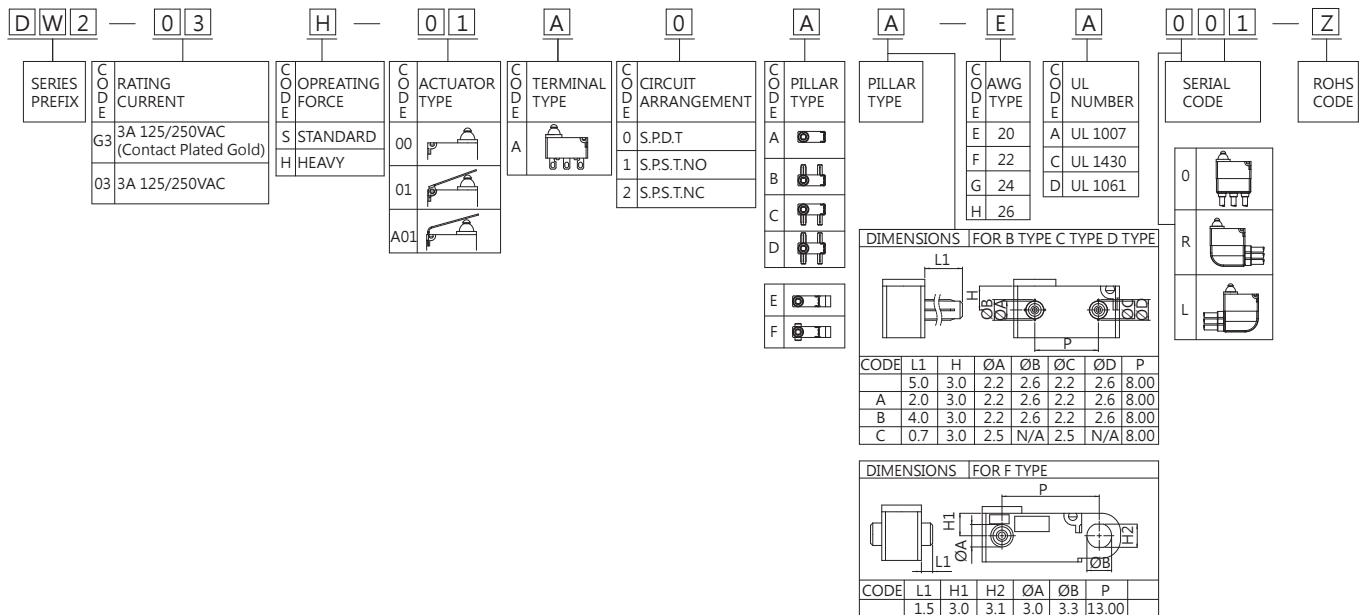

CAUTIONS:

注意事項

1. To secure the switch, please use an M3 small screw on a flat surface and tighten with plane washers or spring washers to securely mount the Switch, using a maximum torque of 0.29 N•m.
若使用定位孔型式上蓋，請使用M3小型螺絲固定在平面上，並使用平墊圈或者彈性墊圈以便安全的鎖固開關，鎖固扭力請勿超過0.29 N•m.
2. Do not handle the switch in a way that may cause damage to the sealed rubber & switch sealing.
使用開關時，請勿損壞開關防水矽膠罩及開關防水膠。
3. Wires should not be dragged.
使用帶線型式時，請注意避免拉扯線材。
4. To ensure the best performance of the switch, when handling/installing the switch, please do not apply uneven pressure to the direction indicated by the arrow in Figure 1. Any uneven pressure or pressure direction other than the operating direction might be harmful or damage the switch performance.
為確保開關正常運作，安裝及取用開關時，請勿直接施加壓力在圖-1中箭頭所指示的方向。如圖所示，任何不對稱的壓力或作動方向以外的壓力都不適用在開關按柄上。
5. Do not exceed the end position (EP) and over travel (OT). This could cause operation failure. (Figure-2)
圖示設計按壓位置，請勿超過開關下死點及超出行程，以避免開關失效。(圖2)
6. Avoid applying any grease/oil and chemicals on the switch rubber.
請避免沾附任何油脂或者化學物質在開關的矽膠防水罩上。

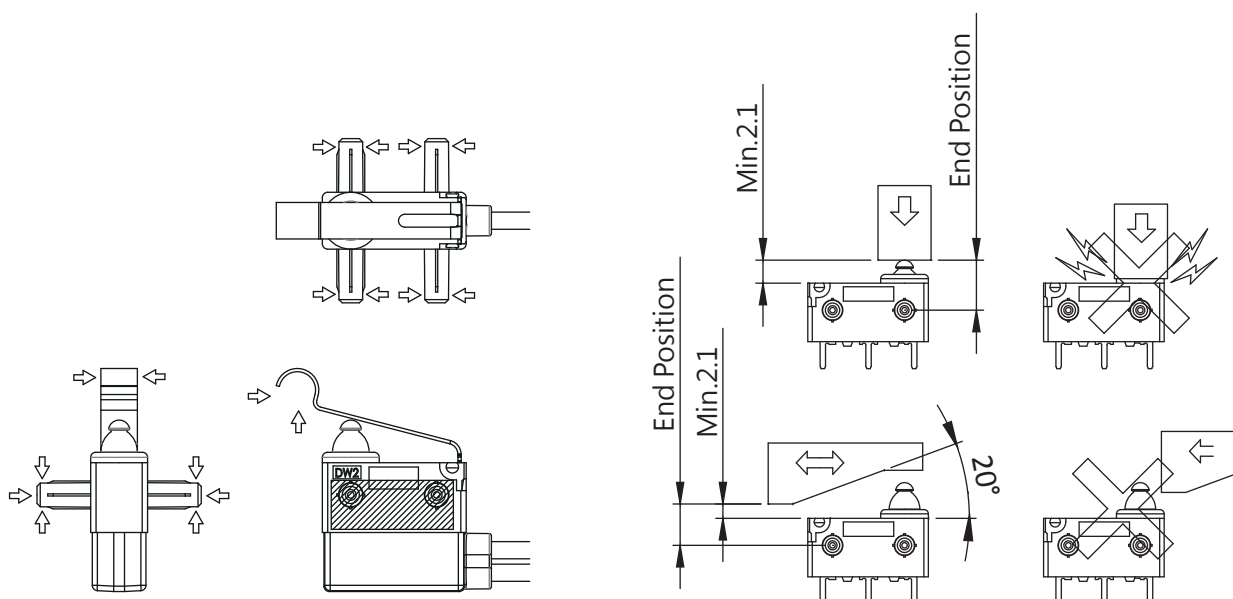
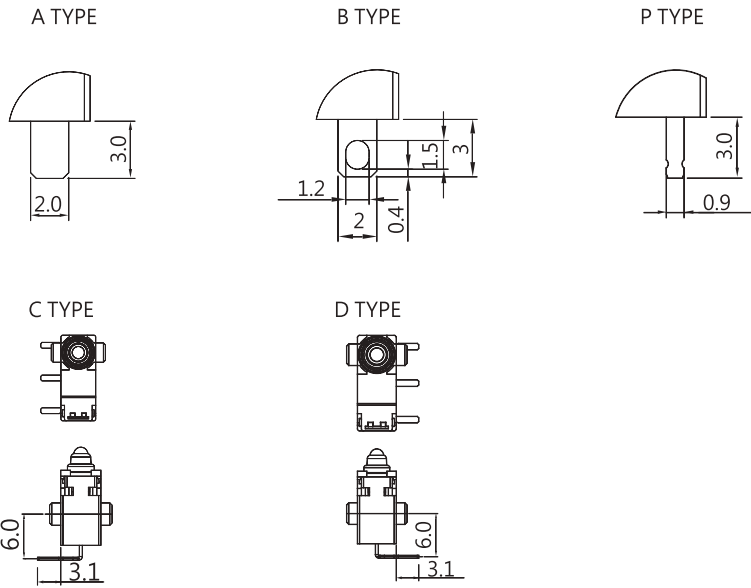

Figure-1

Figure-2

TERMINAL TYPES(THE thickness of each terminal is 0.4 mm)



COVER TYPES (PILLAR & TRAVEL TYPES)

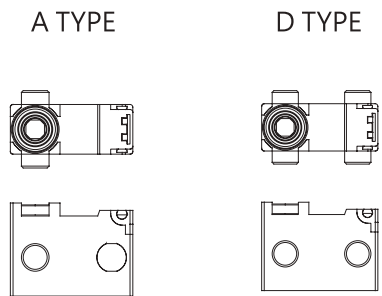

OPERATING CHARACTERISTICS

SWITCH TYPE	PART SUFFIX	OF Max (gf)	FP Max (mm)	NC-OP (mm)	NO-OP (mm)	NC-OT Min.(mm)	NO-OT Min. (mm)
DW3- □□ -00A0-Z		S	153	13.4	12.9±0.3	2.5	2.2
				9.2	8.7±0.3		
DW3- □□ -A01A0-Z		S	185	15.7	14.0±0.6	3.0	2.45
				11.5	9.8±0.6		

CAUTIONS:

注意事項

1. To secure the switch, please use an M3 small screw on a flat surface and tighten with plane washers or spring washers to securely mount the Switch, using a maximum torque of 0.29 N•m.

若使用定位孔型式上蓋，請使用M3小型螺絲固定在平面上，並使用平墊圈或者彈性墊圈以便安全的鎖固開關，鎖固扭力請勿超過0.29 N•m。

2. Do not handle the switch in a way that may cause damage to the sealed rubber & switch sealing.

使用開關時，請勿損壞開關防水矽膠罩及開關防水膠。

3. To ensure the best performance of the switch, when handling/installing the switch, please do not apply uneven pressure to the direction indicated by the arrow in Figure 1. Any uneven pressure or pressure direction other than the operating direction might be harmful or damage the switch performance.

為確保開關正常運作，安裝及取用開關時，請勿直接施加壓力在圖-1中箭頭所指示的方向。如圖所示，任何不對稱的壓力或作動方向以外的壓力都不適用在開關按柄上。

4. Avoid applying any grease/oil and chemicals on the switch rubber.

請避免沾附任何油脂或者化學物質在開關的矽膠防水罩上。

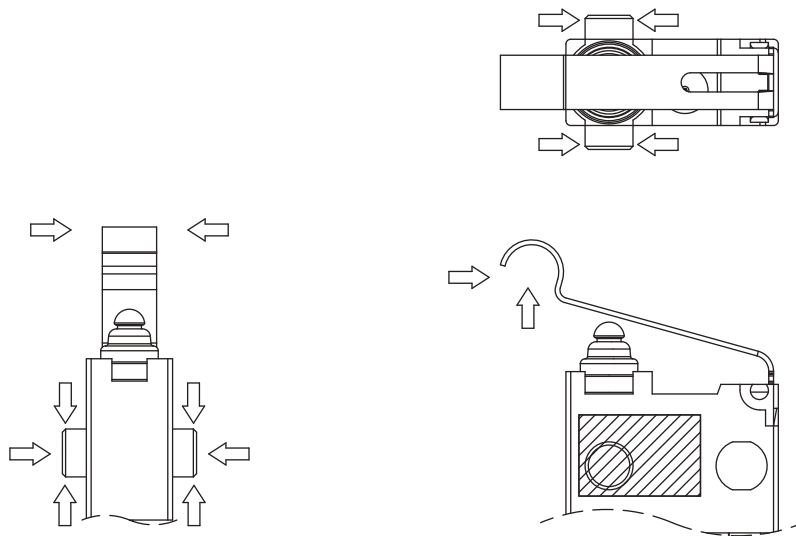
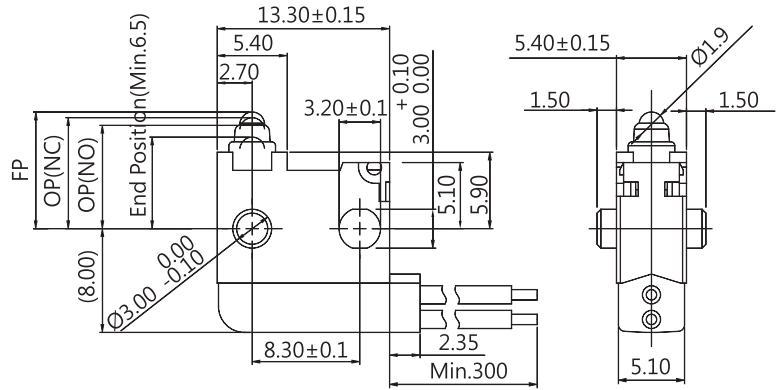

Figure-1

WATER PROOF SWITCHES

DIMENSIONS

Unless otherwise specified, a tolerance of $\pm 0.4\text{mm}$ applies to all dimensions



DW3 (IP67) SERIES

APPLICATION

- Automobiles
(detection of door opening and closing and shift lever position, etc.)
- Household appliances
(propane stoves, vacuum cleaners, air conditioners, Washing machines, etc.)

※ For the specification, please refer to DW3 SERIES. ※

ORDERING INFORMATION

D	W	3	—	G	1		S	—	00	A	0	—	M	F	001	A	—	Z
SERIES PREFIX	CODE	RATING CURRENT	CODE	OPERATING FORCE	CODE	ACTUATOR TYPE	CODE	PILLAR TYPE	CODE	CIRCUIT ARRANGEMENT	CODE	AWG TYPE	CODE	UL NUMBER	SERIAL CODE	SPECIAL CODE	ROHS CODE	
	P1	0.1A 30VDC 0.05A 16VDC 0.001A 5VDC Contact Plated Sliver	S	STANDARD	00		A		0	0 S.P.D.T 1 S.P.S.T-NO 2 S.P.D.T-NC	M	0.3mm ²	F	AVSS	0			
	G1	0.1A 30VDC 0.05A 16VDC 0.001A 5VDC Contact Plated Gold			A01		D											

NOTE: S.P.D.T only for bottom side

0

R

L

DIMENSIONS

CODE	L1	H	ØA	ØB	ØC	ØD	P
A	1.5	5.9	3.0	HOLE 3.2	HOLE 3.0	N/A	8.3
C	1.5	5.9	3.0	3.0	N/A	N/A	8.3

CAUTIONS:

注意事項

1. To secure the switch, please use an M3 small screw on a flat surface and tighten with plane washers or spring washers to securely mount the Switch, using a maximum torque of 0.29 N•m.
若使用定位孔型式上蓋，請使用M3小型螺絲固定在平面上，並使用平墊圈或者彈性墊圈以便安全的鎖固開關，鎖固扭力請勿超過0.29 N•m.
2. Do not handle the switch in a way that may cause damage to the sealed rubber & switch sealing.
使用開關時，請勿損壞開關防水矽膠罩及開關防水膠。
3. Wires should not be dragged.
使用帶線型式時，請注意避免拉扯線材。
4. To ensure the best performance of the switch, when handling/installing the switch, please do not apply uneven pressure to the direction indicated by the arrow in Figure 1. Any uneven pressure or pressure direction other than the operating direction might be harmful or damage the switch performance.
為確保開關正常運作，安裝及取用開關時，請勿直接施加壓力在圖-1中箭頭所指示的方向。如圖所示，任何不對稱的壓力或作動方向以外的壓力都不適用在開關按柄上。
5. Avoid applying any grease/oil and chemicals on the switch rubber.
請避免沾附任何油脂或者化學物質在開關的矽膠防水罩上。

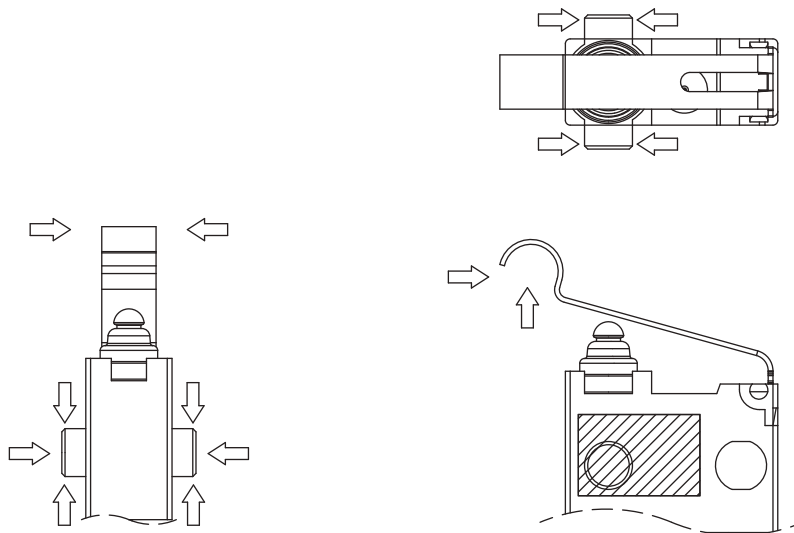
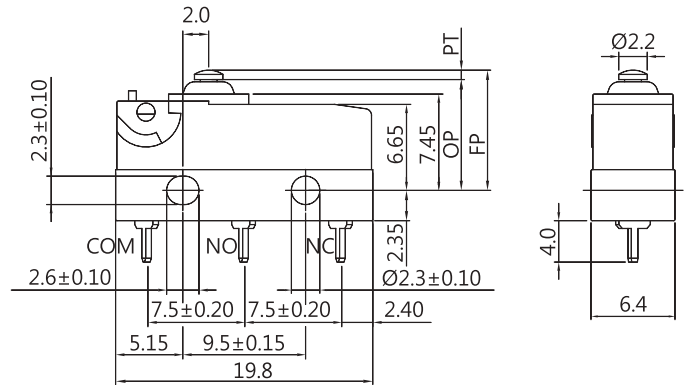

Figure-1

WATER PROOF SWITCHES

DIMENSIONS

Unless otherwise specified, a tolerance of $\pm 0.4\text{mm}$ applies to all dimensions.



SW SERIES

SPECIFICATIONS

Contact Resistance(initial)

Max. 30 m Ω

Measured by ohm meter - open voltage <1VDC, driver current -100 mA

Insulation Resistance (at 500 VDC / minute)

Min. 100 M Ω

Dielectric Strength

Min. 1000VAC(50-60HZ)/minute between Live parts.

Min. 1500VAC(50-60HZ)/minute between Live parts and dead metal parts

Operating Temperature Range

-40°C to 120°C (with no icing)

Vibration

10~55Hz, displacement 0.75 mm (p-p)

Electrical Service Life

Min. 10,000 operations

Electrical Operating Frequency

10~30 operations per minute

Mechanical Service Life

Min. 2,000,000 operations

Mechanical Operating Frequency

120 operations per minute

Operating application of the switch

Set the switch pushing distance from 60% to 90% of the specified OT value

CONTACT CONFIGURATION



MOUNTING HOLES

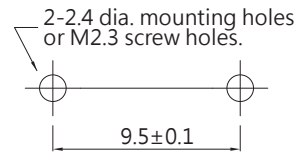

MOUNTING HOLES FOR PCB TERMINAL

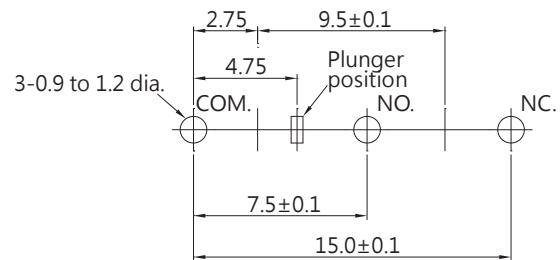

APPLICATIONS

Telephone, Air Conditioner, Computer, Humidifier, Alarm, Time Recorder, Mixer & Chopper, Solder Gun, Neon Phone, Fax Machine, Joystick, Water Pump, Gas Detector, Pencil Sharpener, Money Sorter, Food Processor, Electric Knife, Toy Car, Juice Maker, Electric Steak Pan

CERTIFICATE INFORMATION

Model Name	UL, cUL	ENEC
SW-05	0.1A 125/250VAC 5A 125/250VAC (Temp: 120°C) Min. 6000 operations	6A 250VAC μ T120 1E4

TERMINAL TYPES

A TYPE

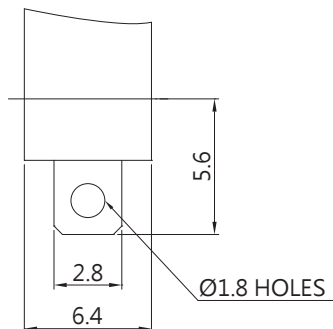

B TYPE

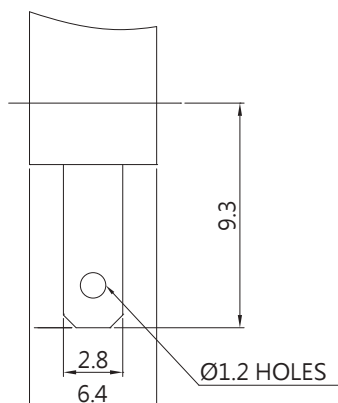

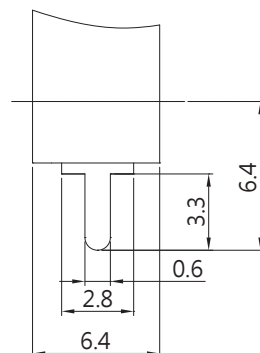

P TYPE

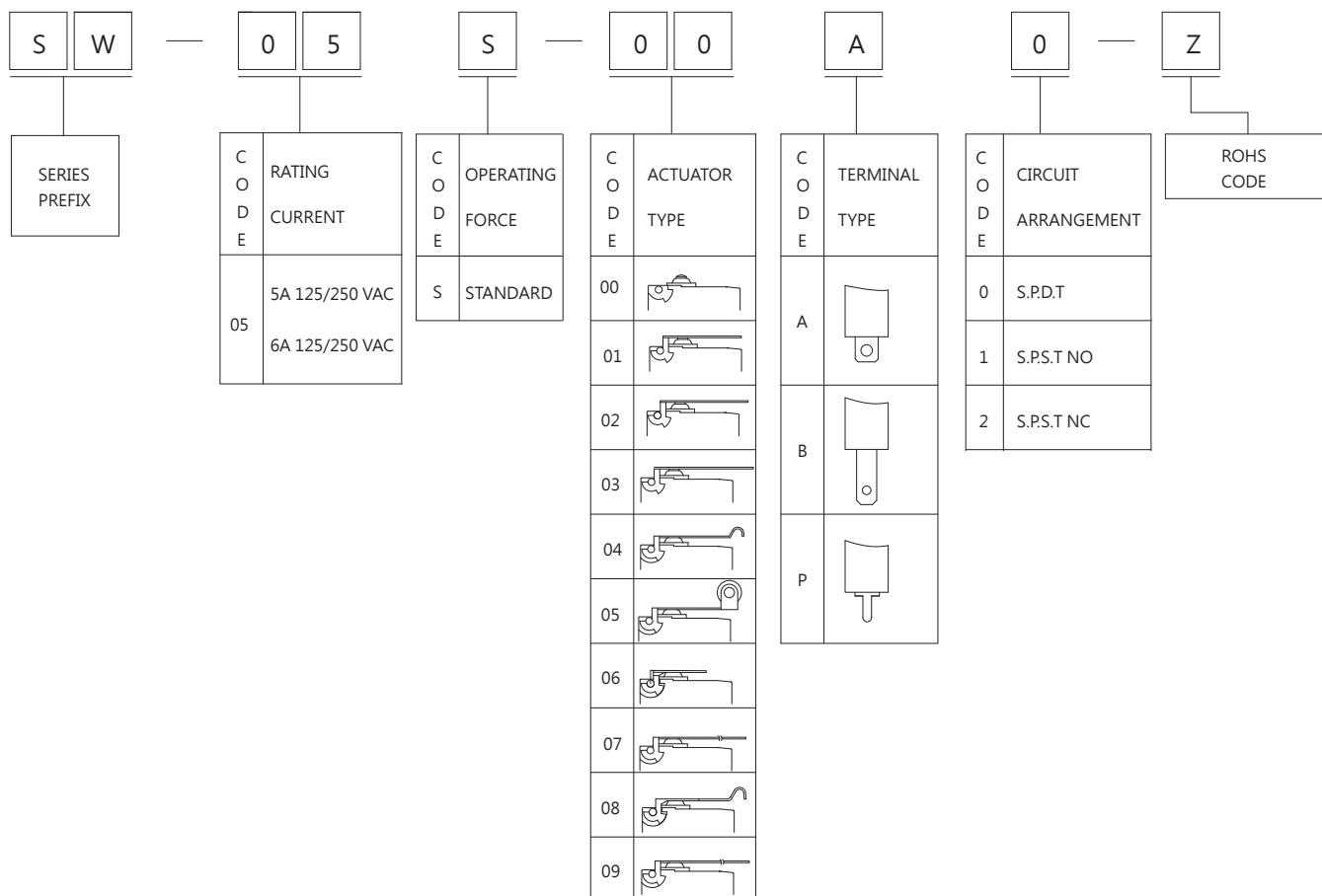

ORDERING INFORMATION

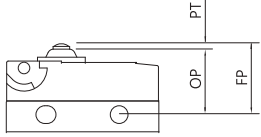
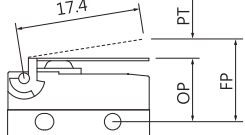
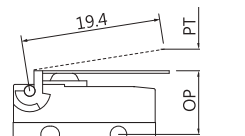
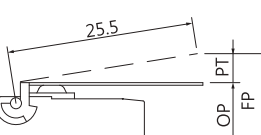
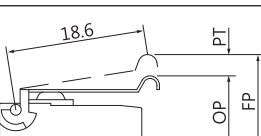
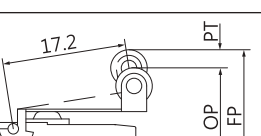

OPERATING CHARACTERISTICS

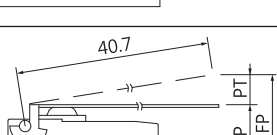
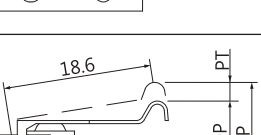
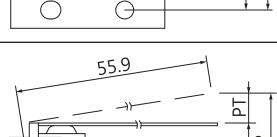
SWITCH TYPE	PART SUFFIX	OF Max. (gf)	OP (mm)	PT Max. (mm)	OT Min. (mm)	MD Max. (mm)	FP Max. (mm)	RF Min. (gf)
SW-05S-00 □□ -Z		203	8.4±0.3	1.2	0.6	0.2	9.9	50
SW-05S-01 □□ -Z		82	8.8±1.1	4.3	0.9	0.6	12.0	16
SW-05S-02 □□ -Z		66	8.8±1.2	4.8	1.0	0.7	12.4	13
SW-05S-03 □□ -Z		54	8.8±1.6	6.3	1.6	0.9	13.5	11
SW-05S-04 □□ -Z		68	10.7±1.2	4.6	1.0	0.65	14.1	14
SW-05S-05 □□ -Z		72	14.5±1.1	4.3	0.9	0.6	17.7	15
SW-05S-06 □□ -Z		98	8.8±0.9	3.2	0.6	0.5	11.1	21
SW-05S-07 □□ -Z		39	8.8±2.6	10.1	2.1	2.3	16.3	8
SW-05S-08 □□ -Z		68	11.3±1.3	4.9	0.95	0.8	14.9	13
SW-05S-09 □□ -Z		33	8.8±3.5	13.8	2.9	3.6	19.1	7

CAUTIONS:

注意事項

1. To secure the switch, please use an M2.3 small screw on a flat surface and tighten with plane washers or spring washers to securely mount the switch, using a maximum torque of 0.16 N•m.
若使用定位孔型式，請使用M2.3小型螺絲固定在平面上，並使用平墊圈或者彈性墊圈以便安全的鎖固開關，鎖固扭力請勿超過0.16 N•m.
2. Do not handle the Switch in a way that may cause damage to the sealed rubber & switch sealing.
使用開關時，請勿損壞開關防水矽膠罩及開關防水膠。
3. To ensure the best performance of the switch, when handling/installing the switch, please do not apply uneven pressure to the direction indicated by the arrow in (Figure -1). Any uneven pressure or pressure direction other than the operating direction might be harmful or damage the switch performance.
為確保開關正常運作，安裝及取用開關時，請勿直接施加壓力在(圖-1)中箭所指示的方向。如圖所示，任何不對稱的壓力或作動方向以外的壓力都不適在開關按柄上。
4. Do not exceed the end position (EP) and over travel (OT). This could cause operation failure.
圖示設計按壓位置，請勿超過開關下死點及超出行程，以避免開關失效。
5. Avoid applying any grease/oil and chemicals on the switch rubber.
請避免沾附任何油脂或者化學物質在開關的矽膠防水罩上。

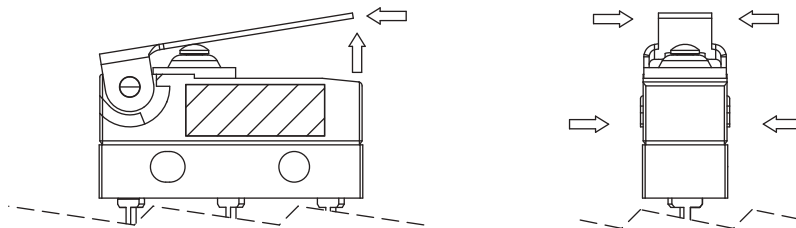
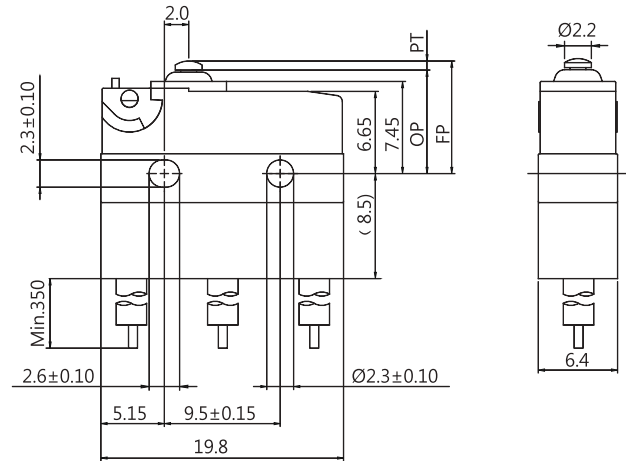

Figure-1

WATER PROOF SWITCHES

DIMENSIONS

Unless otherwise specified, a tolerance of $\pm 0.4\text{mm}$ applies to all dimensions.



SW (IP67) SERIES

APPLICATIONS

Automotive Door Latch, Coffee Machine, Steamer, Telephone, Air Conditioner, Humidifier, Alarm, Time Recorder, Security Device, Mixer & Chopper, Solder Gun, Neon Phone, Fax Machine, Joystick, Water Pump, Gas Detector, Pencil Sharpener, Money Sorter, Food Processor, Electric Knife, Toy Car, Juice Maker, Electric Steak Pan

CERTIFICATE INFORMATION

Model Name	UL, cUL	ENEC
SW-05	0.1A 125/250VAC 5A 125/250VAC (Temp: 120°C) Min. 6000 operations	6A 250VAC μ T70 1E4 (PVC cable) 6A 250VAC μ T120 1E4 (High heat resistant cable)

※ For the specification, please refer to SW SERIES. ※

ORDERING INFORMATION

SERIES PREFIX	RATING CURRENT	OPERATING FORCE	ACTUATOR TYPE	WIRE SIDE	CIRCUIT ARRANGEMENT	AWG TYPE	UL NUMBER	SERIAL CODE	ROHS CODE
SW	05	S	00	A	0	E	A	001	Z
	5A 125/250 VAC 6A 125/250 VAC	STANDARD	00	A	0 S.P.D.T. 1 S.P.S.T. NO 2 S.P.S.T. NC	E 20 F 22 G 24 H 26	UL1007 UL1015 UL1430 UL1061 AV		
			01	B					
			02	C					
			03	D					
			04	E					
			05						
			06						
			07						
			08						
			09						

Note 1: Safety leads wire : AWG: 20~26

2: UL NUMBER CODE: F , AV wire (No safety)

CAUTIONS:

注意事項

1. Wires should not be dragged.
使用帶線型式時，請注意避免拉扯線材。
2. To secure the switch, please use an M2.3 small screw on a flat surface and tighten with plane washers or spring washers to securely mount the switch, using a maximum torque of 0.16 N•m.
若使用定位孔型式，請使用M2.3小型螺絲固定在平面上，並使用平墊圈或者彈性墊圈以便安全的鎖固開關，鎖固扭力請勿超過0.16N•m。
3. Do not handle the Switch in a way that may cause damage to the sealed rubber & switch sealing.
使用開關時，請勿損壞開關防水矽膠罩及開關防水膠。
4. To ensure the best performance of the switch, when handling/installing the switch, please do not apply uneven pressure to the direction indicated by the arrow in (Figure -1). Any uneven pressure or pressure direction other than the operating direction might be harmful or damage the switch performance.
為確保開關正常運作，安裝及取用開關時，請勿直接施加壓力在(圖-1)中箭所指示的方向。如圖所示，任何不對稱的壓力或作動方向以外的壓力都不適在開關按柄上。
5. Do not exceed the end position (EP) and over travel (OT). This could cause operation failure.
圖示設計按壓位置，請勿超過開關下死點及超出行程，以避免開關失效。
6. Avoid applying any grease/oil and chemicals on the switch rubber.
請避免沾附任何油脂或者化學物質在開關的矽膠防水罩上。

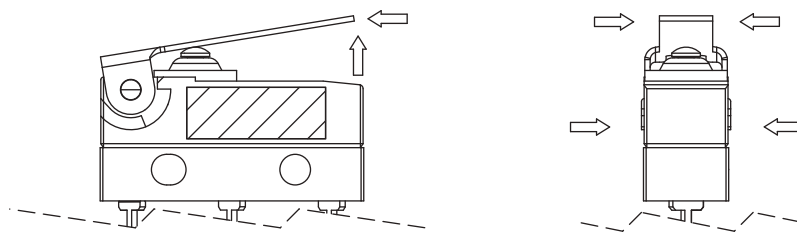

Figure-1

WATER PROOF SWITCHES



DIMENSIONS

Unless otherwise specified, a tolerance of $\pm 0.4\text{mm}$ applies to all dimensions.

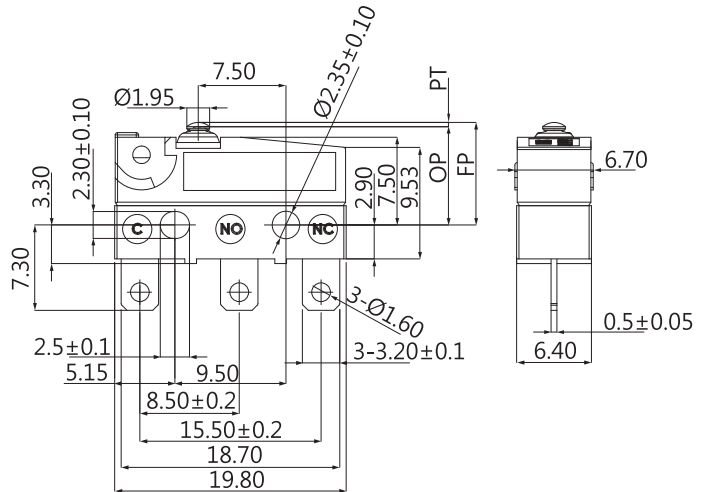

SW1 SERIES

SPECIFICATIONS

Contact Resistance (initial)

Max. 300m Ω

Measured by ohm meter - open voltage < 1VDC, driver current -100 mA

Insulation Resistance (at 500VDC/minute)

Min. 100M Ω

Dielectric Strength

Min. 500VAC(50-60HZ)/minute between Live parts.

Min. 1500VAC(50-60HZ)/minute between Live parts and dead metal parts

Operating Temperature Range

-40°C to 125°C (with no icing)

Vibration

10~55Hz, displacement 0.75 mm (p-p)

Electrical Service Life

Min. 10,000 operations

Electrical Operating Frequency

10~30 operations per minute

Mechanical Service Life

Min. 2,000,000 operations (D, L, S force Only)

Mechanical Operating Frequency

120 operations per minute

Operating application of the switch

Set the switch pushing distance from 60% to 90% of the specified OT value

Degree of Protection

IP67 (excluding the terminals on terminal models)

MOUNTING HOLES

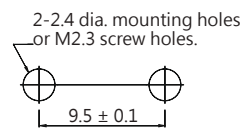

MOUNTING HOLES FOR PCB TERMINAL

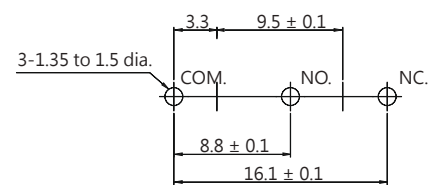

CERTIFICATE INFORMATION

Model Name	UL · cUL	ENEC
SW1-P1	0.1RA 30VDC μ T125 1E4	0.1A 30VDC μ T125 1E4
	0.1RA 125/250VAC μ T125 1E4	0.1A 125/250VAC μ T125 1E4
SW1-06	5RA 30VDC μ T125 1E4	5A 30VDC μ T125 1E4
	6RA 125/250VAC μ T125 1E4	6A 125/250VAC μ T125 1E4
SW1-10	5RA 30VDC μ T125 1E4	5A 30VDC μ T125 1E4
	10RA 125/250VAC μ T125 1E4	10A 125/250VAC μ T125 1E4
SW1-12	5RA 30VDC μ T125 1E4	5A 30VDC μ T125 1E4
	12RA 12GPA 125/250VAC μ T125 1E4	12A 125/250VAC μ T125 1E4

APPLICATIONS

Telephone, Air conditioner, Computer, Humidifier, Alarm, Time recorder, Mixer & Chopper, Solder gun, Neon phone, Fax machine, Joystick, Water pump, Gas detector, Pencil sharpener, Money sorter, Food processor, Electric knife, Toy car, Juice maker, Electric steak pan.

CONTACT CONFIGURATION

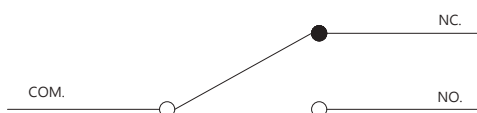

THE SELECTION OF RATING & FORCE

MODEL	Rating	D	L	S	H
SW1	0.1A	*	*	*	*
	6 A		*	*	*
	10A			*	*
	12A				*

NOTE : The Symbol " * " to represent the result is accepted

TERMINAL TYPES (The thickness of terminal is 0.5)

A TYPE
Solder

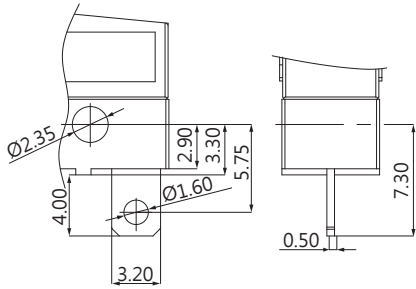

B TYPE
Solder (Long type)

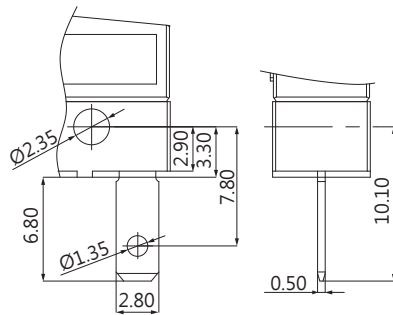

C TYPE
Left side lead PCB

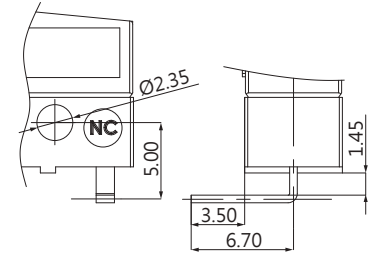

D TYPE
Right side lead PCB

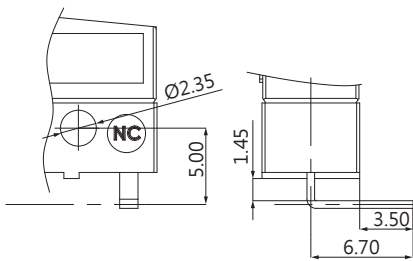

F TYPE
Snap in terminal

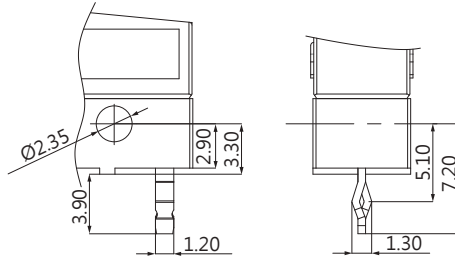

P TYPE
PCB

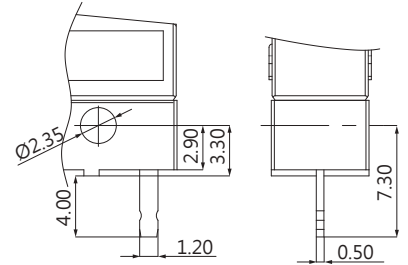

ORDERING INFORMATION

S	W	1	-	P	1	S	1	-	00	A	0	-	Z		
SERIES PREFIX	C O D E	RATING CURRENT		C O D E	OPERATING FORCE	C O D E	COVER TYPE		C O D E	ACTUATOR TYPE	C O D E	TERMINAL TYPE	C O D E	CIRCUIT ARRANGEMENT	ROHS CODE
	P1	0.1A 125/250 VAC		H	HEAVIER	1			00		A		0	S.P.D.T	
	06	6A 125/250 VAC		S	STANDARD				01		B		1	S.P.S.T NO	
	10	10A 125/250 VAC		L	LIGHT				02		C		2	S.P.S.T NC	
	12	12A 125/250 VAC		D	SLIGHT				03		D				
									04		P				
									05		F				
									06						
									07						
									08						
									09						

#NOTE		
ITEM	RATING CURRENT	OPERATION FORCE
1	Code:P1	H,S,L,D
2	Code:06	H,S,L
3	Code:10	H,S
4	Code:12	H

OPERATING CHARACTERISTICS

SWITCH TYPE	PART SUFFIX	OF Max. (gf)		OP (mm)	PT Max. (mm)	OT Min. (mm)	MD Max. (mm)	FP Max. (mm)	RF Min. (gf)	
		H	S						H	S
SW1- □□□□ -00 □□ -Z		H	355	8.4±0.3	1.2	0.6	0.2	9.9	H	100
		S	203						S	50
		L	150						L	30
		D	95						D	10
SW1- □□□□ -01 □□ -Z		H	121	8.8±1.1	4.3	0.9	0.6	12.0	H	22
		S	82						S	16
		L	73						L	14
		D	50						D	4
SW1- □□□□ -02 □□ -Z		H	105	8.8±1.2	4.8	1.0	0.7	12.4	H	20
		S	66						S	13
		L	55						L	11
		D	-						D	-
SW1- □□□□ -03 □□ -Z		H	72	8.8±1.6	6.3	1.6	0.9	13.5	H	17
		S	54						S	11
		L	29						L	6
		D	-						D	-
SW1- □□□□ -04 □□ -Z		H	106	10.7±1.2	4.6	1.0	0.75	14.3	H	15
		S	68						S	14
		L	42						L	7
		D	-						D	-
SW1- □□□□ -05 □□ -Z		H	100	14.5±1.1	4.3	0.9	0.6	17.7	H	20
		S	72						S	15
		L	54						L	4
		D	-						D	-
SW1- □□□□ -06 □□ -Z		H	165	8.8±0.9	3.2	0.6	0.5	11.1	H	23
		S	98						S	21
		L	66						L	10
		D	-						D	-
SW1- □□□□ -07 □□ -Z		H	65	8.8±2.6	10.1	2.1	2.3	16.3	H	8
		S	39						S	8
		L	33						L	1
		D	-						D	-
SW1- □□□□ -08 □□ -Z		H	106	11.3±1.3	4.9	0.95	0.8	14.9	H	14
		S	68						S	13
		L	58						L	11
		D	-						D	-
SW1- □□□□ -09 □□ -Z		H	50	8.8±3.5	13.8	2.9	3.6	19.1	H	7
		S	33						S	7
		L	23						L	1
		D	-						D	-

CAUTIONS:

注意事項

1. To secure the switch, please use an M2.3 small screw on a flat surface and tighten with plane washers or spring washers to securely mount the switch, using a maximum torque of 0.26 N•m.
若使用定位孔型式，請使用M2.3小型螺絲固定在平面上，並使用平墊圈或者彈性墊圈以便安全的鎖固開關，鎖固扭力請勿超過0.26 N•m.
2. Do not handle the Switch in a way that may cause damage to the sealed rubber & switch sealing.
使用開關時，請勿損壞開關防水矽膠罩及開關防水膠。
3. To ensure the best performance of the switch, when handling/installing the switch, please do not apply uneven pressure to the direction indicated by the arrow in (Figure -1). Any uneven pressure or pressure direction other than the operating direction might be harmful or damage the switch performance.
為確保開關正常運作，安裝及取用開關時，請勿直接施加壓力在(圖-1)中箭所指示的方向。如圖所示，任何不對稱的壓力或作動方向以外的壓力都不適在開關按柄上。
4. Do not exceed the end position (EP) and over travel (OT). This could cause operation failure.
圖示設計按壓位置，請勿超過開關下死點及超出行程，以避免開關失效。
5. Avoid applying any grease/oil and chemicals on the switch rubber.
請避免沾附任何油脂或者化學物質在開關的矽膠防水罩上。

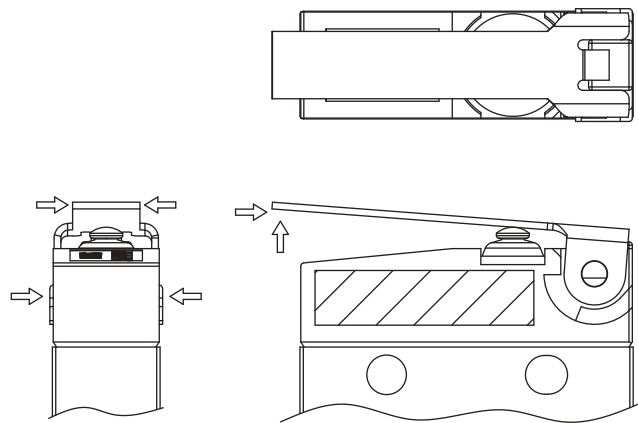
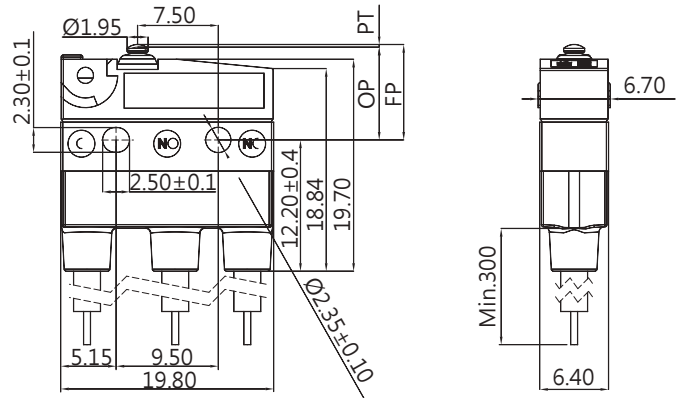

Figure-1

WATER PROOF SWITCHES

DIMENSIONS

Unless otherwise specified, a tolerance of $\pm 0.4\text{mm}$ applies to all dimensions.



SW1 (IP67) SERIES

APPLICATIONS

Telephone, Air conditioner, Computer, Humidifier, Alarm, Time recorder, Mixer & Chopper, Solder gun, Neon phone, Fax machine, Joystick, Water pump, Gas detector, Pencil sharpener, Money sorter, Food processor, Electric knife, Toy car, Juice maker, Electric steak pan.

CERTIFICATE INFORMATION

Model Name	UL · cUL	ENEC
SW1-P1	0.1RA 30VDC μ T55 1E4 0.1RA 125/250VAC μ T55 1E4	0.1A 30VDC μ T55 1E4 0.1A 125/250VAC μ T55 1E4
SW1-06	5RA 30VDC μ T55 1E4 6RA 125/250VAC μ T55 1E4	5A 30VDC μ T55 1E4 6A 125/250VAC μ T55 1E4
SW1-10	5RA 30VDC μ T55 1E4 10RA 125/250VAC μ T55 1E4	5A 30VDC μ T55 1E4 10A 125/250VAC μ T55 1E4
SW1-12	5RA 30VDC μ T55 1E4 12RA 12GPA 125/250VAC μ T55 1E4	5A 30VDC μ T55 1E4 12A 125/250VAC μ T55 1E4

※ For the specification, please refer to SW1 SERIES. ※

THE SELECTION OF RATING & FORCE

MODEL	Rating	D	L	S	H
SW1	0.1A	*	*	*	*
	6 A		*	*	*
	10A			*	*
	12A				*

ORDERING INFORMATION

NOTE : The Symbol " * " to represent the result is accepted

SERIES PREFIX	CODE	RATING CURRENT	CODE	OPERATING FORCE	CODE	COVER TYPE	CODE	ACTUATOR TYPE	CODE	TERMINAL TYPE	CODE	CIRCUIT ARRANGEMENT	CODE	AWG TYPE	CODE	UL NUMBER	SERIAL CODE	ROHS CODE	
SW1	P1	0.1A 125/250 VAC	H	HEAVIER	1		00		A		0	S.P.D.T	E	20	A	UL1007			
	06	6A 125/250 VAC	S	STANDARD			01				1	S.P.S.T NO	F	22	B	UL1015			
	10	10A 125/250 VAC	L	LIGHT			02				2	S.P.S.T NC	G	24	C	UL1430			
	12	12A 125/250 VAC	D	SLIGHT			03						H	26					
							04												
							05												
							06												
							07												
							08												
							09												

#NOTE				
ITEM	RATING CURRENT	OPERATION FORCE	AWG TYPE	LEADS WIRE
1	Code:P1	H,S,L,D	20,22,24,26	Min.30cm
2	Code:06	H,S,L	20,22	Min.30cm
3	Code:10	H,S	20,22	Min.30cm
4	Code:12	H	20	Min.30cm

CAUTIONS:

注意事項

1. Wires should not be dragged.
使用帶線型式時，請注意避免拉扯線材。
2. To secure the switch, please use an M2.3 small screw on a flat surface and tighten with plane washers or spring washers to securely mount the switch, using a maximum torque of 0.26 N•m.
若使用定位孔型式，請使用M2.3小型螺絲固定在平面上，並使用平墊圈或者彈性墊圈以便安全的鎖固開關，鎖固扭力請勿超過0.26 N•m。
3. Do not handle the Switch in a way that may cause damage to the sealed rubber & switch sealing.
使用開關時，請勿損壞開關防水矽膠罩及開關防水膠。
4. To ensure the best performance of the switch, when handling/installing the switch, please do not apply uneven pressure to the direction indicated by the arrow in (Figure -1). Any uneven pressure or pressure direction other than the operating direction might be harmful or damage the switch performance.
為確保開關正常運作，安裝及取用開關時，請勿直接施加壓力在(圖-1)中箭所指示的方向。如圖所示，任何不對稱的壓力或作動方向以外的壓力都不適在開關按柄上。
5. Do not exceed the end position (EP) and over travel (OT). This could cause operation failure.
圖示設計按壓位置，請勿超過開關下死點及超出行程，以避免開關失效。
6. Avoid applying any grease/oil and chemicals on the switch rubber.
請避免沾附任何油脂或者化學物質在開關的矽膠防水罩上。

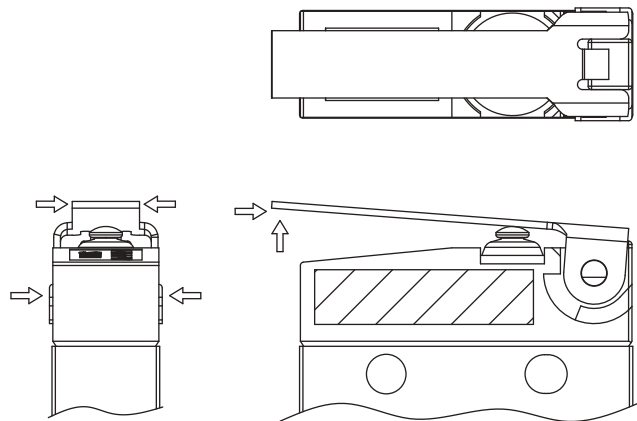
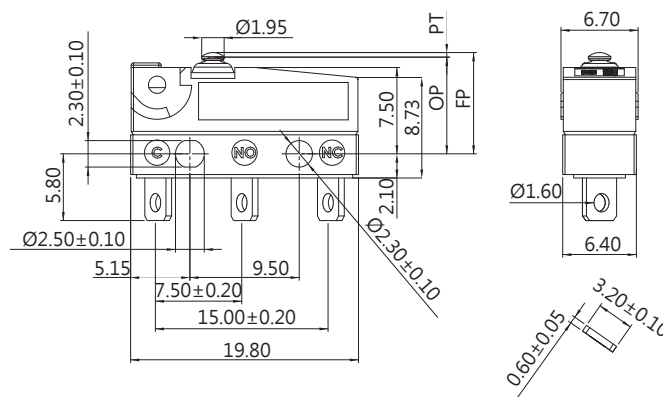

Figure-1

WATER PROOF SWITCHES

DIMENSIONS

Unless otherwise specified, a tolerance of $\pm 0.4\text{mm}$ applies to all dimensions.



SW2 SERIES

SPECIFICATIONS

Contact Resistance (initial)

Max. 300mΩ

Measured by ohm meter - open voltage < 1VDC, driver current -100 mA

Insulation Resistance (at 500VDC/minute)

Min. 100MΩ

Dielectric Strength

Min. 500VAC(50-60HZ)/minute between Live parts.

Min. 1500VAC(50-60HZ)/minute between Live parts and dead metal parts

Operating Temperature Range

-40°C to 125°C (with no icing)

Vibration

10~55Hz, displacement 0.75 mm (p-p)

Electrical Service Life

Min. 10,000 operations

Electrical Operating Frequency

10~30 operations per minute

Mechanical Service Life

Min. 2,000,000 operations

Mechanical Operating Frequency

120 operations per minute

Operating application of the switch

Set the switch pushing distance from 60% to 90% of the specified OT value

MOUNTING HOLES

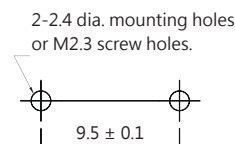

MOUNTING HOLES FOR PCB TERMINAL

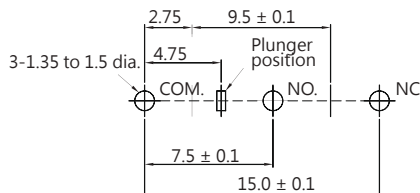

CERTIFICATE INFORMATION

Model Name	UL · cUL	ENEC
SW2-C1	0.1RA 125/250VAC uT125 1E4	0.1A 125/250VAC uT125 1E4
SW2-C3	3GPA 125/250VAC uT125 1E4	3A 125/250VAC uT125 1E4
SW2-06	5RA 30VDC uT125 1E4	5A 30VDC uT125 1E4
	6GPA 125/250VAC uT125 1E4	6A 125/250VAC uT125 1E4
SW2-10	5RA 30VDC uT125 1E4	5A 30VDC uT125 1E4
	10RA125/250VAC uT125 1E4	10(2)A 125/250VAC uT125 1E4
	10GPA 125/250VAC uT125 1E4	
SW2-H10	5RA 30VDC uT125 1E4	5A 30VDC uT125 1E4
	10RA125/250VAC uT125 1E4	10(2)A 125/250VAC uT125 1E4
	10GPA 125/250VAC uT125 1E4	
	1/4HP 125/250VAC uT125 1E4	

APPLICATIONS

Telephone, Air conditioner, Computer, Humidifier, Alarm, Time recorder, Mixer & Chopper, Solder gun, Neon phone, Fax machine, Joystick, Water pump, Gas detector, Pencil sharpener, Money sorter, Food processor, Electric knife, Toy car, Juice maker, Electric steak pan.

CONTACT CONFIGURATION

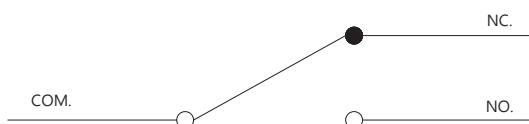

THE SELECTION OF RATING & FORCE

MODEL	Rating	L	S	H
SW2	0.1A	*	*	*
	3A	*	*	*
	6A	*	*	*
	10A 10(2)A		*	*
	1/4 hp 10A 10(2)A		*	*

NOTE : The Symbol " * " to represent the result is accepted

TERMINAL TYPES (THE thickness of each terminal is 0.6 mm)

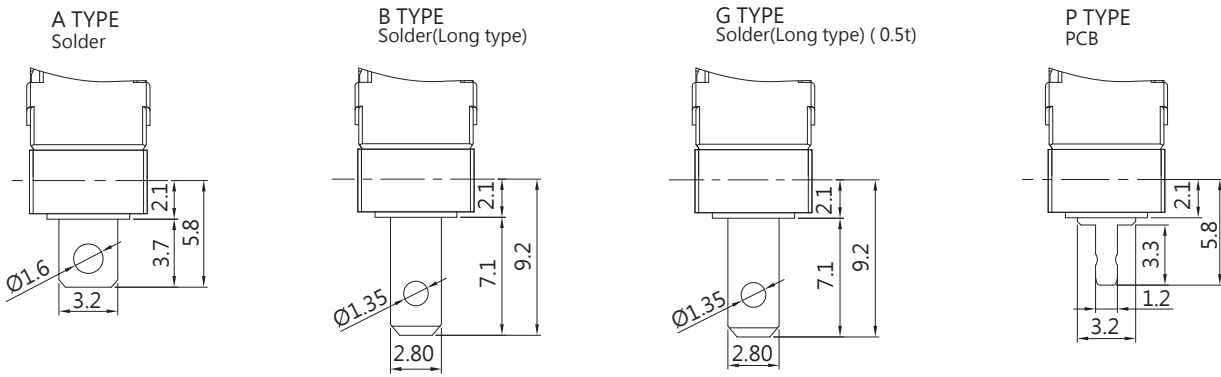

ORDERING INFORMATION

S	W	2	—	0	6	S	1	—	0	0	A	0	—	Z
SERIES PREFIX				RATING CURRENT		OPERATING FORCE		COVER TYPE		ACTUATOR TYPE		CIRCUIT ARRANGEMENT		ROHS CODE
C1				0.1A 125/250 VAC		H HEAVIER		1		00		0 S.P.D.T		
C3				3A 125/250 VAC		S STANDARD				01		1 S.P.S.T NO		
06				6A 125/250 VAC		L LIGHT				02		2 S.P.S.T NC		
10				10A 125/250 VAC						03				
10(2)A				125/250 VAC						04				
10A				125/250 VAC						05				
10(2)A				125/250 VAC						06				
1/4 hp				125/250 VAC						07				
										08				
										09				

#NOTE		
	RATING CURRENT	OPERATING FORCE
1	Code:C1	L, S, H
	Code:C3	L, S, H
	Code:06	L, S, H
	Code: 10	S, H
	Code:H10	S, H

OPERATING CHARACTERISTICS

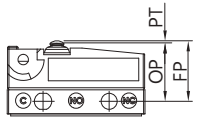
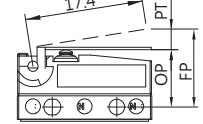
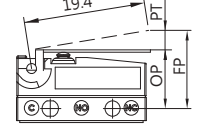
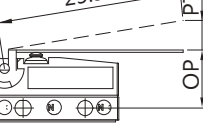
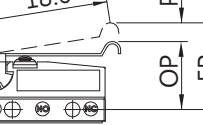
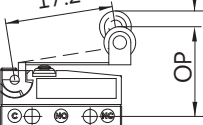
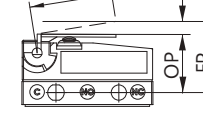
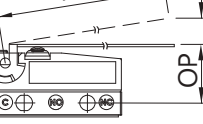
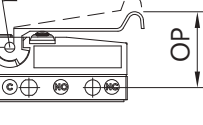
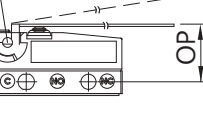
SWITCH TYPE	PART SUFFIX	OF Max. (gf)		OP (mm)	PT Max. (mm)	OT Min. (mm)	MD Max. (mm)	FP Max. (mm)	RF Min. (gf)	
		H	S						H	S
SW2- □□□□ -00 □□ -Z		H	300	8.4 ± 0.3	1.2	0.4	0.2	9.9	H	70
		S	203						S	50
		L	150						L	30
SW2- □□□□ -01 □□ -Z		H	121	8.8 ± 1.1	4.3	0.6	0.6	1.2	H	17
		S	82						S	16
		L	73						L	14
SW2- □□□□ -02 □□ -Z		H	105	8.8 ± 1.2	4.8	0.67	0.7	12.4	H	14
		S	66						S	13
		L	55						L	11
SW2- □□□□ -03 □□ -Z		H	72	8.8 ± 1.6	6.3	0.89	0.9	13.5	H	12
		S	54						S	11
		L	29						L	6
SW2- □□□□ -04 □□ -Z		H	106	10.7 ± 1.2	4.6	0.64	0.75	14.3	H	15
		S	68						S	14
		L	42						L	7
SW2- □□□□ -05 □□ -Z		H	100	14.5 ± 1.1	4.3	0.6	0.6	17.7	H	16
		S	72						S	15
		L	54						L	4
SW2- □□□□ -06 □□ -Z		H	165	8.8 ± 0.9	3.2	1.0	0.5	11.1	H	23
		S	98						S	21
		L	66						L	10
SW2- □□□□ -07 □□ -Z		H	65	8.8 ± 2.6	10.1	1.5	2.3	16.3	H	8
		S	39						S	8
		L	33						L	1
SW2- □□□□ -08 □□ -Z		H	106	11.3 ± 1.3	4.9	0.6	0.8	14.9	H	14
		S	68						S	13
		L	42						L	6
SW2- □□□□ -09 □□ -Z		H	50	8.8 ± 3.5	13.8	1.0	3.6	19.1	H	7
		S	33						S	7
		L	23						L	1

CAUTIONS:

注意事項

1. To secure the switch, please use an M2.3 small screw on a flat surface and tighten with plane washers or spring washers to securely mount the switch, using a maximum torque of 0.26 N•m.
若使用定位孔型式，請使用M2.3小型螺絲固定在平面上，並使用平墊圈或者彈性墊圈以便安全的鎖固開關，鎖固扭力請勿超過0.26 N•m.
2. Do not handle the Switch in a way that may cause damage to the sealed rubber & switch sealing.
使用開關時，請勿損壞開關防水矽膠罩及開關防水膠。
3. To ensure the best performance of the switch, when handling/installing the switch, please do not apply uneven pressure to the direction indicated by the arrow in (Figure -1). Any uneven pressure or pressure direction other than the operating direction might be harmful or damage the switch performance.
為確保開關正常運作，安裝及取用開關時，請勿直接施加壓力在(圖-1)中箭所指示的方向。如圖所示，任何不對稱的壓力或作動方向以外的壓力都不適在開關按柄上。
4. Do not exceed the end position (EP) and over travel (OT). This could cause operation failure.
圖示設計按壓位置，請勿超過開關下死點及超出行程，以避免開關失效。
5. Avoid applying any grease/oil and chemicals on the switch rubber.
請避免沾附任何油脂或者化學物質在開關的矽膠防水罩上。

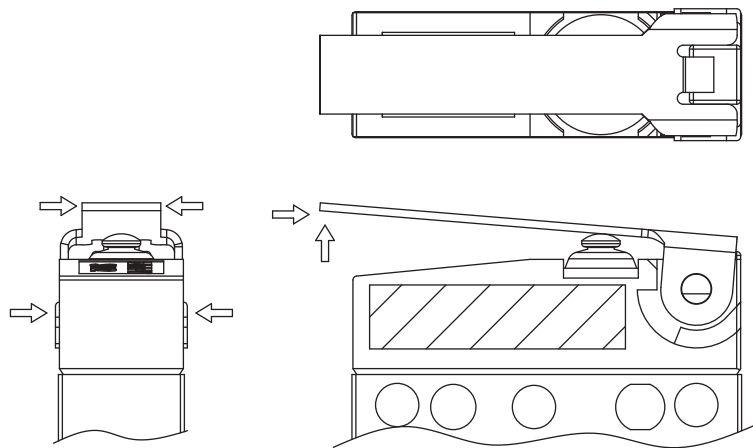

Figure-1

WATER PROOF SWITCHES



DIMENSIONS

Unless otherwise specified, a tolerance of $\pm 0.4\text{mm}$ applies to all dimensions.

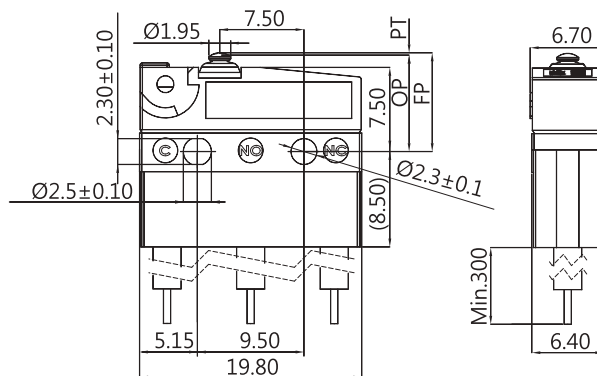

SW2 (IP67) SERIES

APPLICATIONS

Telephone, Air conditioner, Computer, Humidifier, Alarm, Time recorder, Mixer & Chopper, Solder gun, Neon phone, Fax machine, Joystick, Water pump, Gas detector, Pencil sharpener, Money sorter, Food processor, Electric knife, Toy car, Juice maker, Electric steak pan.

※ For the specification, please refer to SW2 SERIES. ※

THE SELECTION OF RATING & FORCE

MODEL	Rating	L	S	H
SW2	0.1A	*	*	*
	3A	*	*	*
	6A	*	*	*
	10A 10(2)A		*	*
	1/4 hp 10A 10(2)A		*	*

NOTE : The Symbol " * " to represent the result is accepted

CERTIFICATE INFORMATION

Model Name	UL · cUL	ENEC
SW2-C1	0.1RA 125/250VAC uT55 1E4	0.1A 125/250VAC uT55 1E4
SW2-C3	3GPA 125/250VAC uT55 1E4	3A 125/250VAC uT55 1E4
SW2-06	5RA 30VDC uT55 1E4	5A 30VDC uT55 1E4
	6GPA 125/250VAC uT55 1E4	6A 125/250VAC uT55 1E4
SW2-10	5RA 30VDC uT55 1E4	5A 30VDC uT55 1E4
	10RA 125/250VAC uT55 1E4	10(2)A 125/250VAC uT55 1E4
SW2-H10	5RA 30VDC uT55 1E4	5A 30VDC uT55 1E4
	10RA125/250VAC uT55 1E4	
	10GPA 125/250VAC uT55 1E4 1/4HP 125/250VAC uT55 1E4	

ORDERING INFORMATION

SW2 - 06 S 1 - 00 0 0 - E A 001 - Z

SERIES PREFIX	CODE	RATING CURRENT	CODE	OPERATING FORCE	CODE	COVER TYPE	CODE	ACTUATOR TYPE	CODE	WIRE SIDE	CODE	CIRCUIT ARRANGEMENT	CODE	AWG TYPE	CODE	UL NUMBER	SERIAL CODE	ROHS CODE	
	C1	0.1A 125/250 VAC	H	HEAVIER	1		00		0		0	S.P.D.T	E	20	A	UL1007			
	C3	3A 125/250 VAC	S	STANDARD			01					1	S.P.S.T NO	F	22	B	UL1015		
	06	6A 125/250 VAC	L	LIGHT			02					2	S.P.S.T NC	G	24	C	UL1430		
	10	10A 125/250 VAC 10(2)A 125/250 VAC					03			R				H	26	D	UL1061		
	H10	10A 125/250 VAC 10(2)A 125/250 VAC 1/4 hp 125/250 VAC					04			L						F	AV		
							05												
							06												
							07												
							08												
							09												

#NOTE			
RATING CURRENT	AWG TYPE	LEADS WIRE	OPERATING FORCE
Code:C1	20,22,24,26	Min.30cm	L, S, H
Code:C3	20,22,24,26	Min.30cm	L, S, H
Code:06	20,22	Min.30cm	L, S, H
Code:10	20	Min.30cm	S, H
Code:H10	20	Min.30cm	S, H
2	UL number code:F.AV wire(no safety).		

CAUTIONS:

注意事項

1. Wires should not be dragged.
使用帶線型式時，請注意避免拉扯線材。
2. To secure the switch, please use an M2.3 small screw on a flat surface and tighten with plane washers or spring washers to securely mount the switch, using a maximum torque of 0.26 N•m.
若使用定位孔型式，請使用M2.3小型螺絲固定在平面上，並使用平墊圈或者彈性墊圈以便安全的鎖固開關，鎖固扭力請勿超過0.26 N•m。
3. Do not handle the Switch in a way that may cause damage to the sealed rubber & switch sealing.
使用開關時，請勿損壞開關防水矽膠罩及開關防水膠。
4. To ensure the best performance of the switch, when handling/installing the switch, please do not apply uneven pressure to the direction indicated by the arrow in (Figure -1). Any uneven pressure or pressure direction other than the operating direction might be harmful or damage the switch performance.
為確保開關正常運作，安裝及取用開關時，請勿直接施加壓力在(圖-1)中箭所指示的方向。如圖所示，任何不對稱的壓力或作動方向以外的壓力都不適在開關按柄上。
5. Do not exceed the end position (EP) and over travel (OT). This could cause operation failure.
圖示設計按壓位置，請勿超過開關下死點及超出行程，以避免開關失效。
6. Avoid applying any grease/oil and chemicals on the switch rubber.
請避免沾附任何油脂或者化學物質在開關的矽膠防水罩上。

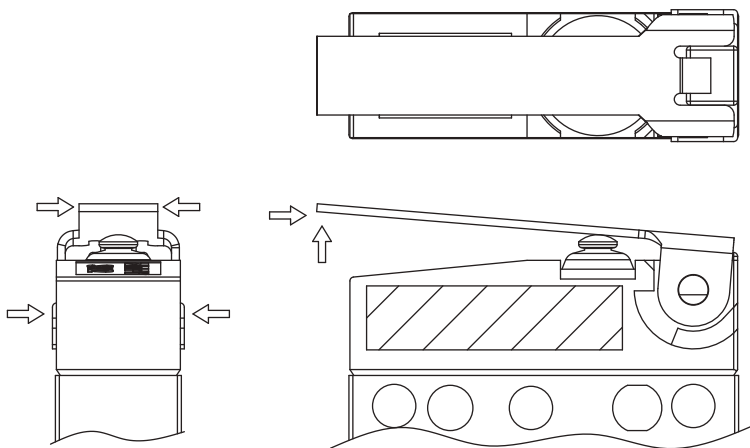
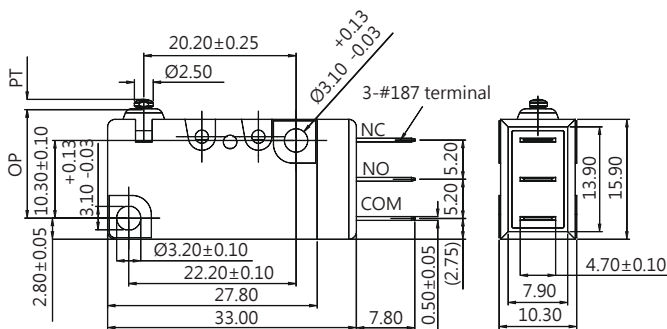

Figure-1

WATER PROOF SWITCHES

DIMENSIONS

Unless otherwise specified, a tolerance of $\pm 0.4\text{mm}$ applies to all dimensions.



VW1 SERIES

SPECIFICATIONS

Contact Resistance (initial)

Max. 300m Ω

Measured by ohm meter - open voltage < 1VDC, driver current -100 mA

Insulation Resistance (at 500VDC/minute)

Min. 100M Ω

Dielectric Strength

Min. 500VAC(50-60HZ)/minute between Live parts.

Min. 1500VAC(50-60HZ)/minute between Live parts and dead metal parts

Operating Temperature Range

-40°C to 85°C (with no icing)

Vibration

10~55Hz, displacement 0.75 mm (p-p)

Electrical Service Life

Min. 10,000 operations

Electrical Operating Frequency

10~30 operations per minute

Mechanical Service Life

Min. 1,000,000 operations

Mechanical Operating Frequency

120 operations per minute

Operating application of the switch

Set the switch pushing distance from 60% to 90% of the specified OT value

APPLICATIONS

Alarm device, Home security, Time recorder, Air conditioner, Food processor, Juice maker, Lawnmower, Mixer, Central water heater, Industrial apparatus, Special forklifts, Special vehicles

CONTACT CONFIGURATION

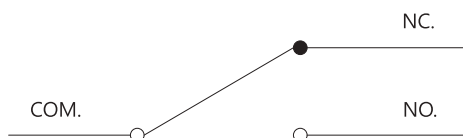

MOUNTING HOLES

2- $\varnothing 3.1$ mounting holes or M3 screw holes

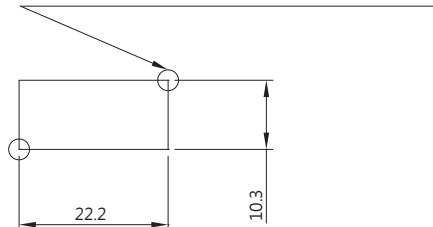

TERMINAL TYPES

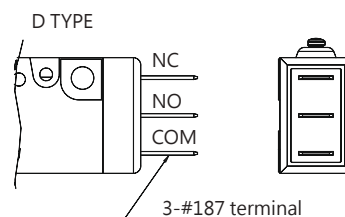

THE SELECTION OF RATING & FORCE

MODEL	Rating	D	J	L	S	H
VW1	0.1A	*	*	*	*	*
	3A	*	*	*	*	*
	6 A	*	*	*	*	*
	10 A				*	*

NOTE : The Symbol " * " to represent the result is accepted

CERTIFICATE INFORMATION

Model Name	UL	ENEC
VW1-P1	0.1RA 30VDC μ T85 1E4	0.1A 30VDC μ T85 1E4
	0.1RA 125/250VAC μ T85 1E4	0.1A 125/250VAC μ T85 1E4
VW1-03	3RA 30VDC μ T85 1E4	3A 30VDC μ T85 1E4
	3RA 125/250VAC μ T85 1E4	3A 125/250VAC μ T85 1E4
VW1-06	5RA 30VDC μ T85 1E4	5A 30VDC μ T85 1E4
	6RA 125/250VAC μ T85 1E4	6A 125/250VAC μ T85 1E4
VW1-10	5RA 30VDC μ T85 1E4	5A 30VDC μ T85 1E4
	10RA 125/250VAC μ T85 1E4	10A 125/250VAC μ T85 1E4

ORDERING INFORMATION

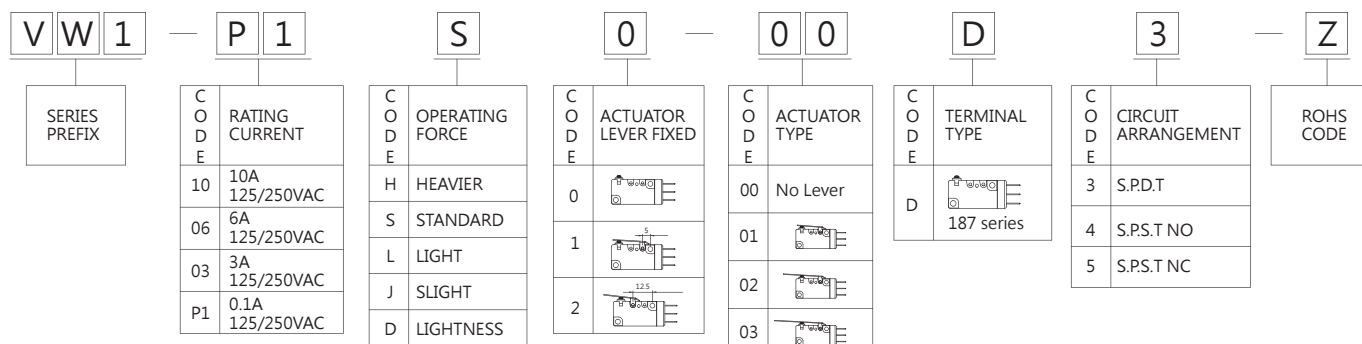

#NOTE		
ITEM	RATING CURRENT	OPERATING FORCE
1	Code : P1	H, S, L, J, D
2	Code : 03	H, S, L, J, D
3	Code : 06	H, S, L, J, D
4	Code : 10	H, S

OPERATING CHARACTERISTICS

SWITCH TYPE	PART SUFFIX	OF Max. (gf)					OP (mm)	PT Max. (mm)	OT Min. (mm)	MD Max. (mm)
		D	J	L	S	H				
VW1- □□□ 0-00 □□ -Z		50	100	150	200	300	14.7 ± 0.4	1.2	1.0	0.4
VW1- □□□ 1-01 □□ -Z		45	85	125	160	255	15.1 ± 0.6	2.6	1.1	0.6
VW1- □□□ 2-01 □□ -Z		25	55	75	90	145	15.0 ± 1.1	5.1	1.2	1.1
VW1- □□□ 1-02 □□ -Z		30	60	85	110	160	14.8 ± 0.8	4.0	1.5	0.9
VW1- □□□ 2-02 □□ -Z		20	40	60	75	110	14.5 ± 1.6	8	2.4	1.8
VW1- □□□ 1-03 □□ -Z		20	40	55	70	100	H force:			
							12.4 ± 2.0	7.0	-	2.5
							D, J, L, S force:			
							13.4 ± 2.0	7.0	-	2.0
VW1- □□□ 2-03 □□ -Z		15	28	40	50	70	H force:			
							11.9 ± 3.3	16.5	-	3.0
							D, J, L, S force:			
							12.9 ± 3.3	17.5	-	3.0
VW1- □□□ 1-04 □□ -Z		36	65	95	125	185	18.1 ± 0.8	3.6	1.7	1.0
VW1- □□□ 2-04 □□ -Z		20	45	60	75	110	17.6 ± 1.5	7.2	2.1	1.7
VW1- □□□ 1-05 □□ -Z		55	100	150	200	300	20.6 ± 0.5	2.1	1.0	0.5
VW1- □□□ 2-05 □□ -Z		30	65	98	150	175	20.4 ± 0.9	4.2	1.2	0.9
VW1- □□□ 1-06 □□ -Z		40	70	105	130	195	20.4 ± 0.7	3.3	1.3	0.7
VW1- □□□ 2-06 □□ -Z		25	43	60	70	105	20.2 ± 1.2	6.5	1.5	1.4

* There is another series of VW1 with MD reduced to 63%.

CAUTIONS:

注意事項

1. To secure the switch, please use an M2.3 small screw on a flat surface and tighten with plane washers or spring washers to securely mount the switch, using a maximum torque of 0.59 N•m.
若使用定位孔型式，請使用M2.3小型螺絲固定在平面上，並使用平墊圈或者彈性墊圈以便安全的鎖固開關，鎖固扭力請勿超過0.59 N•m.
2. Do not handle the Switch in a way that may cause damage to the sealed rubber & switch sealing.
使用開關時，請勿損壞開關防水矽膠罩及開關防水膠。
3. To ensure the best performance of the switch, when handling/installing the switch, please do not apply uneven pressure to the direction indicated by the arrow in (Figure -1). Any uneven pressure or pressure direction other than the operating direction might be harmful or damage the switch performance.
為確保開關正常運作，安裝及取用開關時，請勿直接施加壓力在(圖-1)中箭所指示的方向。如圖所示，任何不對稱的壓力或作動方向以外的壓力都不適在開關按柄上。
4. Do not exceed the end position (EP) and over travel (OT). This could cause operation failure.
圖示設計按壓位置，請勿超過開關下死點及超出行程，以避免開關失效。
5. Avoid applying any grease/oil and chemicals on the switch rubber.
請避免沾附任何油脂或者化學物質在開關的矽膠防水罩上。

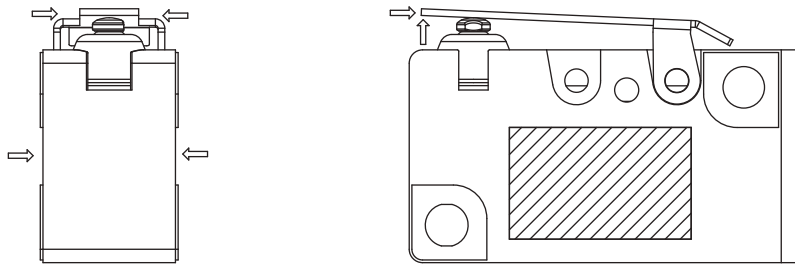

Figure-1

WATER PROOF SWITCHES



DIMENSIONS

Unless otherwise specified, a tolerance of $\pm 0.4\text{mm}$ applies to all dimensions.

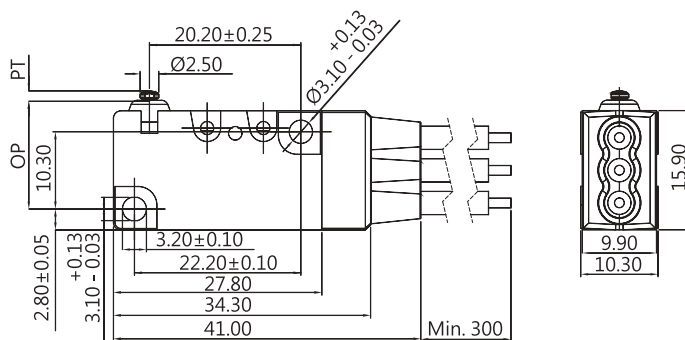

VW1 (IP67) SERIES

APPLICATIONS

Alarm devices, Home security, Time recorder, Air conditioner, Food processor, Juice maker, Lawnmowers, Mixer, Central water heater, Industrial apparatus, Special forklifts, Special vehicles

TERMINAL TYPES

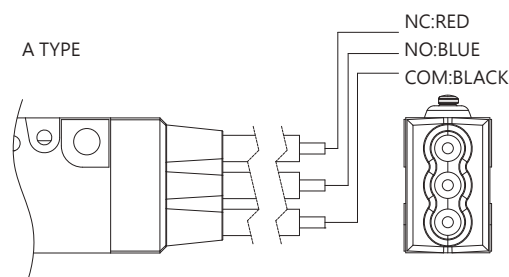

CERTIFICATE INFORMATION

Model Name	UL	ENEC
VW1-P1	0.1RA 30VDC μ T55 1E4 0.1RA 125/250VAC μ T55 1E4	0.1A 30VDC μ T55 1E4 0.1A 125/250VAC μ T55 1E4
VW1-03	3RA 30VDC μ T55 1E4 3RA 125/250VAC μ T55 1E4	3A 30VDC μ T55 1E4 3A 125/250VAC μ T55 1E4
VW1-06	5RA 30VDC μ T55 1E4 6RA 125/250VAC μ T55 1E4	5A 30VDC μ T55 1E4 6A 125/250VAC μ T55 1E4
VW1-10	5RA 30VDC μ T55 1E4 10RA 125/250VAC μ T55 1E4	5A 30VDC μ T55 1E4 10A 125/250VAC μ T55 1E4

※ For the specification, please refer to VW1 SERIES. ※

THE SELECTION OF RATING & FORCE

MODEL	Rating	D	J	L	S	H
VW1	0.1A	*	*	*	*	*
	3A	*	*	*	*	*
	6 A	*	*	*	*	*
	10 A				*	*

NOTE : The Symbol " * " to represent the result is accepted

ORDERING INFORMATION

SERIES PREFIX	RATING CURRENT	OPERATING FORCE	ACTUATOR LEVER FIXED	ACTUATOR TYPE	TERMINAL TYPE	CIRCUIT ARRANGEMENT	AWG TYPE	UL NUMBER	SERIAL CODE	ROHS CODE
VW1	10 10A 125/250VAC	H HEAVIER	0 0	00 No Lever	A NC:RED NO:BLUE COM:BLACK	0 S.P.D.T	C 16	B UL1015		Z
	06 6A 125/250VAC	S STANDARD	1 5	01		1 S.P.S.T NO	D 18			
	03 3A 125/250VAC	L LIGHT	2 12.5	02		2 S.P.S.T NC	E 20			
	P1 0.1A 125/250VAC	J SLIGHT		03			F 22			
		D LIGHTNESS		04			G 24			
				05			H 26			
				06						

#NOTE				
ITEM	RATING CURRENT	OPERATING FORCE	AWG TYPE	LEADS WIRE
1	Code : P1	H, S, L, J, D	16, 18, 20, 22, 24, 26	Min.30 cm
2	Code : 03	H, S, L, J, D	16, 18, 20	Min.30 cm
3	Code : 06	H, S, L, J, D	16, 18	Min.30 cm
4	Code : 10	H, S	16	Min.30 cm

CAUTIONS:

注意事項

1. To secure the switch, please use an M2.3 small screw on a flat surface and tighten with plane washers or spring washers to securely mount the switch, using a maximum torque of 0.59 N•m.
若使用定位孔型式，請使用M2.3小型螺絲固定在平面上，並使用平墊圈或者彈性墊圈以便安全的鎖固開關，鎖固扭力請勿超過0.59 N•m.
2. Do not handle the Switch in a way that may cause damage to the sealed rubber & switch sealing.
使用開關時，請勿損壞開關防水矽膠罩及開關防水膠。
3. To ensure the best performance of the switch, when handling/installing the switch, please do not apply uneven pressure to the direction indicated by the arrow in (Figure -1). Any uneven pressure or pressure direction other than the operating direction might be harmful or damage the switch performance.
為確保開關正常運作，安裝及取用開關時，請勿直接施加壓力在(圖-1)中箭所指示的方向。如圖所示，任何不對稱的壓力或作動方向以外的壓力都不適在開關按柄上。
4. Wires should not be dragged.
使用帶線型式時，請注意避免拉扯線材。
5. Do not exceed the end position (EP) and over travel (OT). This could cause operation failure.
圖示設計按壓位置，請勿超過開關下死點及超出行程，以避免開關失效。
6. Avoid applying any grease/oil and chemicals on the switch rubber.
請避免沾附任何油脂或者化學物質在開關的矽膠防水罩上。

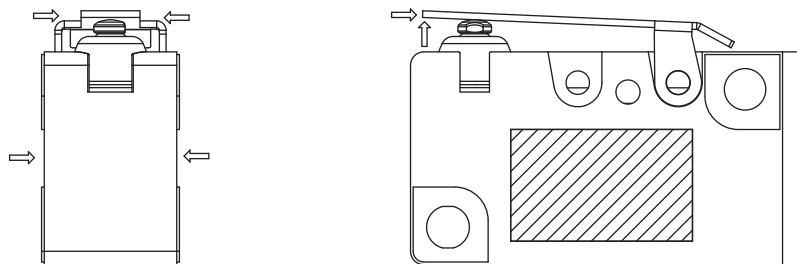

Figure-1

WATER PROOF SWITCHES



MP SERIES

SPECIFICATIONS

Contact Resistance(initial)

Max. 500 mΩ

Measured by ohm meter -open voltage < 1VDC, driver current -100 mA)

Insulation Resistance(at 100 VDC / minute)

Min. 100 MΩ

Dielectric Strength

Min. 1000VAC(50-60HZ)/minute between Live parts and dead metal parts

Operating Temperature Range

-10°C to 65°C (with no icing)

Vibration

10~55 Hz, displacement 0.75 mm(p-p)

Electrical Service Life

Min. 200,000 operations.

Electrical Operating Frequency

Max. 30 operations per minute

Operating Force

Max. 90gf

Operating Position

10° ± 4°

Degree of Protection

IP67 (excluding the terminals on terminal models)

RATING

0.1A 12VDC

APPLICATIONS

Automobile, Home appliances, Robot and industrial machines

ORDERING INFORMATION

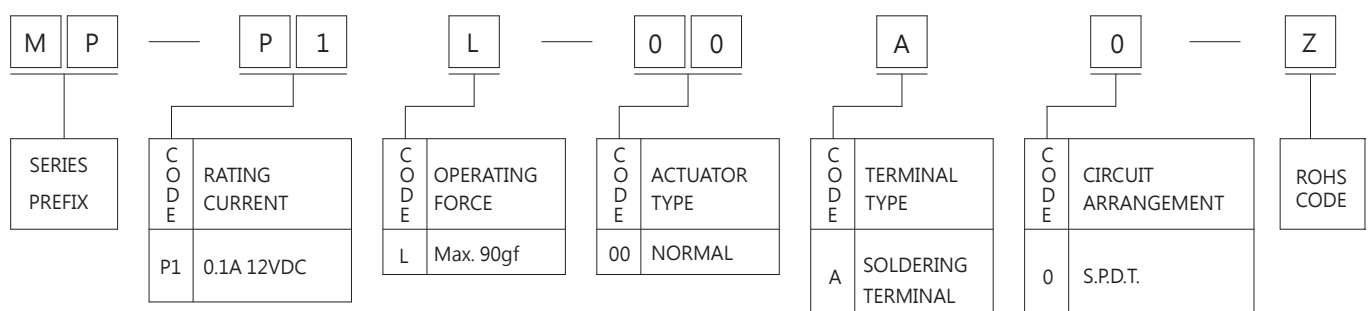

DIMENSIONS

Unless otherwise specified, a tolerance of ±0.4mm applies to all dimensions.

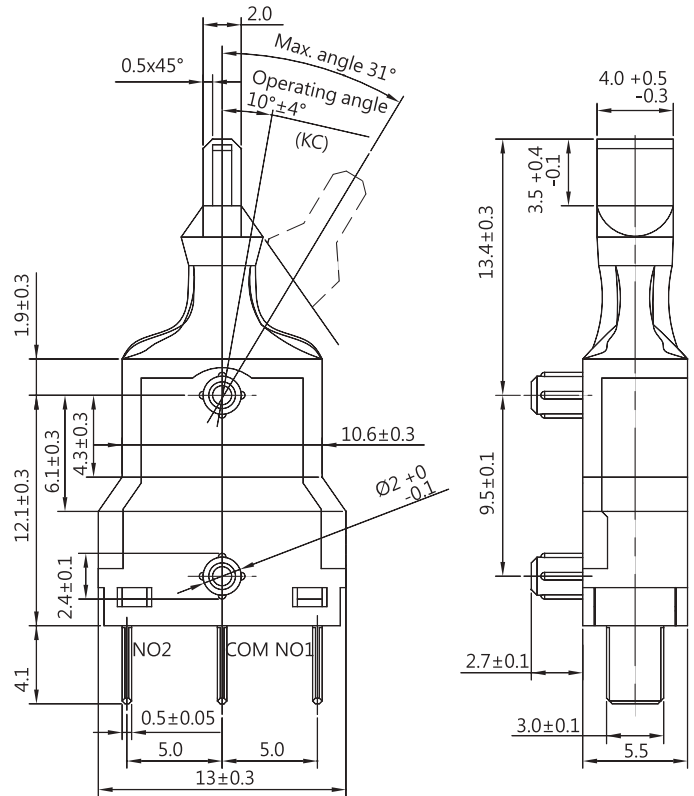

CONTACT CONFIGURATION

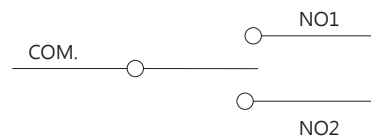

PILLAR PITCH

