

Radar Level Transmitter

GLT721

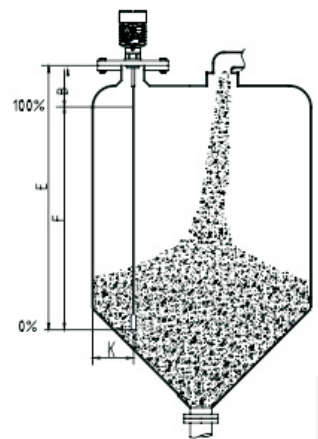
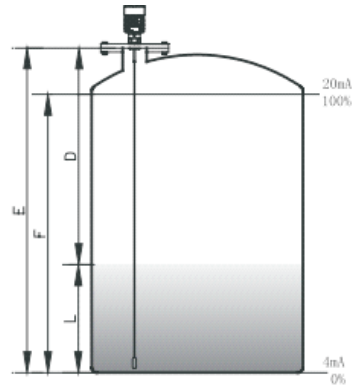

MEASURING PRINCIPLE

Guided Wave Radar is the measuring instruments that based on the time travel principle, the radar wave travel in speed of light, run time can be converted into a level signal by the electronic component. The probe emit the high-frequency pulse and spread along the cable probe, the pulse come across the material surface and reflect back then receive by the instrument receiver and converted the distance signal to level signal.

INPUT

Reflected pulse signal conduction transmit along the cable to the electronic circuit part of the instrument, the microprocessor processes this signal, identify the echo that generated by the microwave pulses on the material surface. Correct echo signal recognition accomplish by the intelligent software, the distance D that from the material surface is proportional to the pulse time travel T : $D=C \times T/2$ (C represent for speed of light) As the empty tank distance E is already known, the level L is: $L = E - D$.

OUTPUT

By entering the empty tank height E (= zero), full tank height F (= full scale) and some applications parameters to set up, application parameters will automatically adapt the measurement environment. Corresponds to 4-20mA output.

MEASURING RANGE

- F----Measuring range
- E----Empty tank distance
- B--- Top blind zone
- K---- Mini. Distance from probe to tank wall

The top blind zone is the minimum distance between the highest material surface and the measurement reference point.

The bottom blind zone refers to the distance that near the mooring rope bottom and cannot be accurate measured.

The distance between the top and the bottom blind zone is the effective measurement distance.

Note:

The tank level can be measured reliably only when the material is between the blind zone of top and bottom

TECHNICAL PARAMETER

Application	Liquid, solid particles with high dielectric constant
Measuring range	20meter
Process connection	Screw thread, Flange
Medium Temperature	-40~250°C
Process pressure	-0.1~2MPa
Accuracy	± 3mm
Frequency range	100MHZ-1.8GHZ
Anti-explosion/safety grade	Exia II CT6 Ga/Exd ia II CT6 Gb / IP67
Signal output	4~20mA/HART(Two-wire/Four-wire)

OUTER DIMENSION

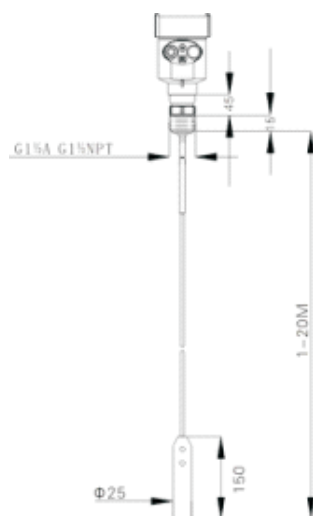

INSTALLATION

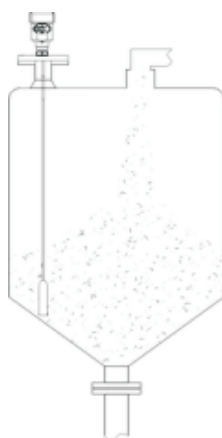

MODEL SELECTION

Element	Code	Parameter
Anti-explosion	P	Standard (non-Ex)
	I	Intrinsic safety (ExiaIICT6 Ga)
	D	Intrinsic safety+Exd (Exd ia II CT6 Gb)
Sensor/Cable type probe	A	Liquid type/4mm
	B	Solid type/6mm
Process connection/Material	G	Screw thread G1½A stainless steel
	GA	Screw thread G½A stainless steel
	N	Screw thread 1½NPT stainless steel
	NA	Screw thread ½NPT stainless steel
	A	Flange DN50 PN16C stainless steel
	B	Flange DN80 PN16C stainless steel
	C	Flange DN100 PN16C stainless steel
	D	Flange DN150 PN16C stainless steel
	E	Flange DN200 PN16C stainless steel
	H	Flange DN250 PN16C stainless steel
	Y	Special custom
Seal/Process temperature	P	Common seal/-40...120°C
	G	High-temperature seal/-40...250°C with radiator
Electronic unit	2	(4 ~ 20) mA / 24V DC / two-wire system
	3	(4 ~ 20) mA / 24V DC / HART two-wire system
	4	(4 ~ 20) mA / 24V DC / HART four-wire system
	5	(4 ~ 20) mA / (85~ 265) V AC / DC / HART four-wire system
Housing/Protection grade	L	Aluminum / IP67
	G	Aluminum / IP67 Double chamber
Cable entry	M	M20*1.5
	N	½ NPT
Live display/ Programming	A	With
	X	Without
Special custom	Y	Special custom

YTK CO.,LTD.

[Http://www.ytk-group.co.jp](http://www.ytk-group.co.jp)