



# E-bike Battery (Inner Battery Series) TC-GERLON



MSDS

UN38.3



Model	IG	
Maximum cells	50 (18650)	40 (18650)
Max capacity	36V17.5Ah	36V14Ah
Charging port	DC2.1 Opt. 3Pin high current	
Discharge port	6Pin	
LED indicator	single LED with three colours	
USB port	without	
Power switch	without	
L1-L2(mm)	426x350	361x285

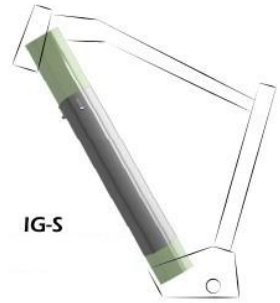

IG-S

Down tube



IG-T

Model:IG-T



T:up-take style

Model:IG-U / IG-S



U:down-take style,case with safety lock lever  
S:side-take style,case with safety lock lever

Model:IG-PLUS-T



T:up-take style

Model:IG-PLUS-U / IG-PLUS-S



U:down-take style,case with safety lock lever  
S:side-take style,case with safety lock lever



IG-PLUS-T



IG-PLUS-U

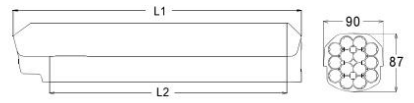

Model	IG-PLUS	
Maximum cells	70 (18650)	52 (18650)
Max capacity	36V24.5Ah 48V17.5Ah	36V17.5Ah 48V14Ah
Charging port	DC2.1 Opt. 3Pin high current	
Discharge port	6Pin	
LED indicator	single LED with three colours	
USB port	without	
Power switch	without	
L1-L2 (mm)	426x350	361x285

# E-bike Battery (Inner Battery Series) TC-BEE



MSDS

UN38.3



Model	IB	
Maximum cells	40 (18650)	30 (18650)
Max capacity	36V14Ah	36V10.5Ah
Charging port	DC2.1 Opt. 3Pin high current	
Discharge port	6Pin	
LED indicator	single LED with three colours	
USB port	without	
Power switch	without	
L1·L2 (mm)	434x356	369x291

Standard patent lock

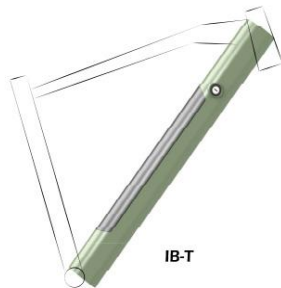

IB-T

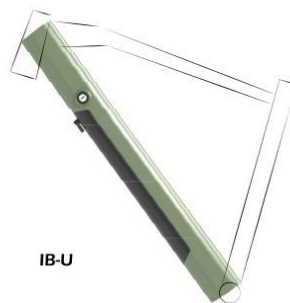

IB-U

## Model:IB-T



T代表上取式：电池盒铝壳上方平整  
T:up-take style

## Model:IB-U



U代表下取式：电池盒铝壳上有限位扳手 前盖带锁舌  
U:down-take style,case with safety lock lever

## Model:IB-PLUS-T



T:up-take style

## Model:IB-PLUS-U



U:down-take style,case with safety lock lever

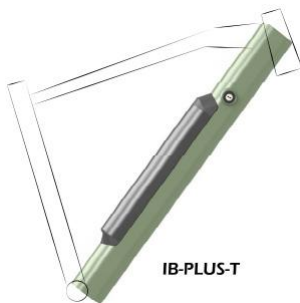

IB-PLUS-T

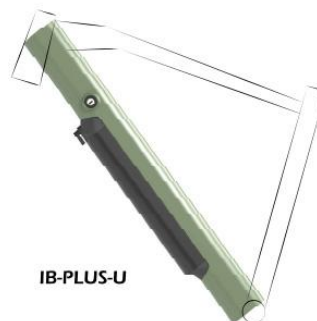

IB-PLUS-U

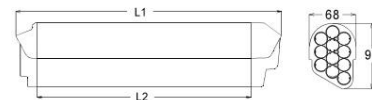

Model	IB-PLUS	
Maximum cells	52 (18650)	40 (18650)
Max capacity	36V17.5Ah 48V14Ah	36V14Ah
Charging port	DC2.1 Opt. 3Pin high current	
Discharge port	6Pin	
LED indicator	single LED with three colours	
USB port	without	
Power switch	without	
L1·L2(mm)	434x356	369x291

Standard patent lock



# E-bike Battery (Inner Battery Series) TC-WASP



MSDS

UN38.3



Model	IW	
Maximum cells	50 (18650)	40 (18650)
Max capacity	36V17.5Ah	36V14Ah
Charging port	DC2.1 Opt. 3Pin high current	
Discharge port	6Pin	
LED indicator	single LED with three colours	
USB port	without	
Power switch	without	
L1·L2 (mm)	434x356	369x291

Down tube

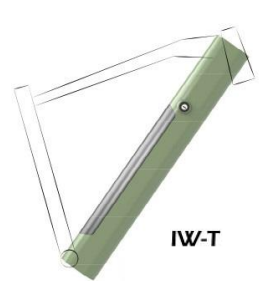

IW-T

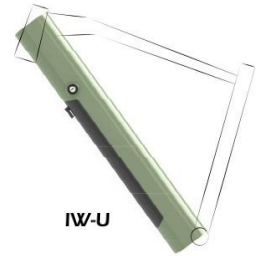

IW-U

Model:IW-T



Trip-take style

Model:IW-U



U:down-take style, case with safety lock lever



# E-bike Battery (Inner Battery Series) TC-RHINO5

Model:IR-5

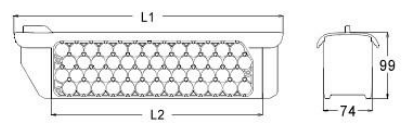

FR-5 Folding model



IR-5T pper tube type



IR-5U Tube type removal

Model	IR-5
Maximum cells	52 (18650)
Max capacity	36V17.5Ah / 48V14Ah
Charging port	DC2.1 Opt. 3Pin high current
Discharge port	6Pin
LED indicator	4 LED lights
USB port	without
Power switch	without
L1·L2 (mm)	362.5x274.5



# E-bike Battery (Inner Battery Series) TC-RHIN07



MSDS

UN38.3



Model	IR-7	
Maximum cells	70 (18650)	42 (21700)
Max capacity	36V24.5Ah 48V17.5Ah	36V20Ah 48V15Ah
Charging port	DC2.1 Opt. 3Pin high current	
Discharge port	6Pin	
LED indicator	4 LED lights	
USB port	without	
Power switch	without	
L1-L2 (mm)	441x355	



Model:IR-7

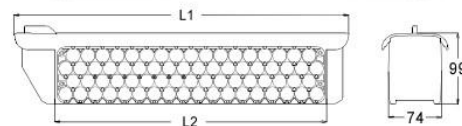
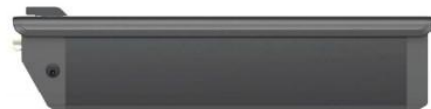

# E-bike Battery (Inner Battery Series) TC-RHINO21700

Model:IR-21700

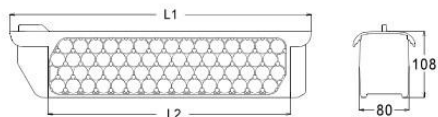
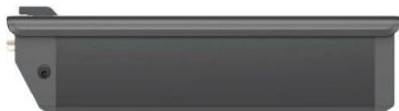

Model	IR-21700	
Maximum cells	60 (21700)	
Max capacity	36V30Ah	48V20Ah
Charging port	DC2.1 Opt. 3Pin high current	
Discharge port	6Pin	
LED indicator	4 LED lights	
USB port	without	
Power switch	without	
L1-L2 (mm)	441x355	

# E-bike Battery (Inner Battery Series) TC-DRAGONFLY



MSDS

UN38.3

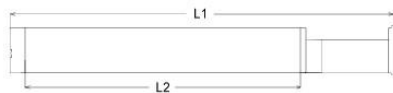

Model	IF-2C	IF-3C	IF-4C
Maximum cells	28 (18650)	30 (18650)	40 (18650)
Max capacity	24V14Ah	36V10.5Ah	36V14Ah
Charging port	DC2.1 Opt. 3Pin high current		
Discharge port	2Pin Opt. 6Pin		
LED indicator	without		
USB port	without		
Power switch	without		
Controller box*	with		
L1·L2 (mm)	680x510	610x460	545x395



IF-2C



IF-3C



IF-4C

Model:IF-2C



Model:IF-3C



Model:IF-4C



# E-bike Battery (Inner Battery Series) TC-HIPPO

Model:IH-6

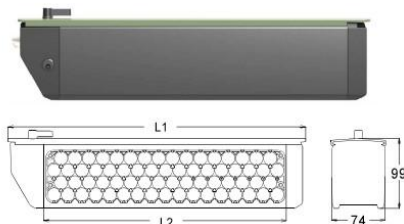

Down tube



The logo can be customized on both sides of the lower pipe

Model	IH-6	
Maximum cells	65 (18650)	42 (21700)
Max capacity	36V21Ah 48V17.5Ah	36V20Ah 48V17.5Ah
Charging port	DC2.1 Opt. 3Pin high current	
Discharge port	6Pin	
LED indicator	4 LED lights	
USB port	without	
Power switch	without	
L1·L2(mm)	410x337	

# E-bike Battery (Inner Battery Series) TC-SNAIL



MSDS

UN38.3



Model	SS-18650
Maximum cells	20 (18650)
Max capacity	36V7Ah
Charging port	DC2.1 Opt. 3Pin high current
Discharge port	2Pin
LED indicator	without
USB port	without
Power switch	without
L1-L2 (mm)	595x520

\*Optional patent seat clamp



Model:SS-18650

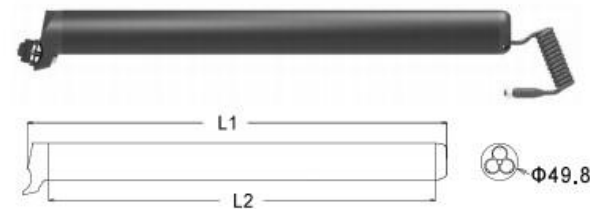

Model:SS-21700

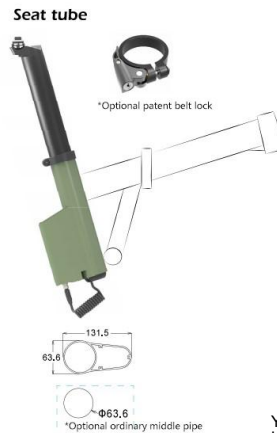

Model	SS-21700
Maximum cells	20 (21700)
Max capacity	36V10Ah
Charging port	DC2.1 Opt. 3Pin high current
Discharge port	2Pin
LED indicator	without
USB port	without
Power switch	without
L1-L2 (mm)	630x555

\*Optional patent seat clamp

# E-bike Battery (Inner Battery Series) TC-EEL



MSDS

UN38.3



Model	IE-MINI	
Maximum cells	40 (18650)	30 (18650)
Max capacity	36V14Ah	36V10.5Ah
Charging port	DC2.1 Opt. 3Pin high current	
Discharge port	2Pin Opt. 6Pin	
LED indicator	single LED with three colours	
USB port	without	
Power switch	without	
L1·L2(mm)	430x354	365x289

\*Single layer pipe matching plastic cover PLA0335

Down tube



\*Existing pipe type of section A, B, C and D

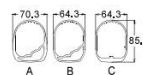

\*Existing pipe type of Section D



Model:IE-MINI

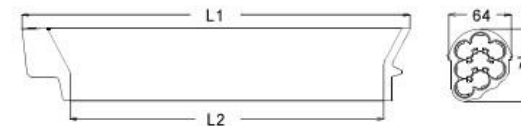

Model:IE-PRO

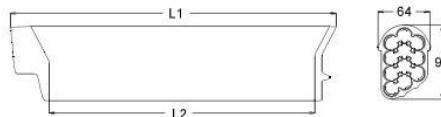

Down tube

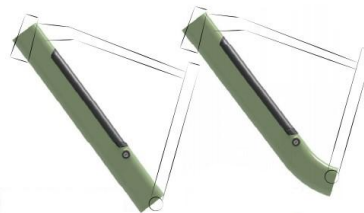

\*Existing pipe type of section A, B, C and D

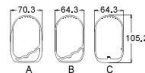

\*Existing pipe type of Section D



Model	IE-PRO	
Maximum cells	52 (18650)	40 (18650)
Max capacity	36V17.5Ah 48V14Ah	36V14Ah
Charging port	DC2.1 Opt. 3Pin high current	
Discharge port	2Pin Opt. 6Pin	
LED indicator	single LED with three colours	
USB port	without	
Power switch	without	
L1·L2(mm)	430x354	365x289

\*Single layer pipe matching plastic cover PLA0335



# E-bike Battery (Inner Battery Series) TC-DORADO



MSDS

UN38.3



Model:ID-21700

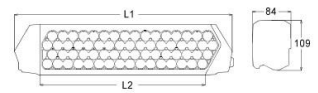

Model	ID-21700	
Maximum cells	65 (21700)	52 (21700)
Max capacity	36V30Ah 48V25Ah	36V25Ah 48V20Ah
Charging port	DC2.1 Opt. 3Pin high current	
Discharge port	2Pin Opt. 5Pin	
LED indicator	4 LED lights	
USB port	with	
Power switch	without	
L1-L2 (mm)	458x343.6	393x278.6

Down tube

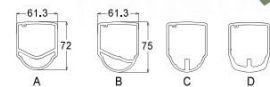

Model:ID-MAX

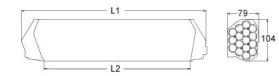

Model	ID-MAX	
Maximum cells	80 (18650)	60 (18650)
Max capacity	36V28Ah 48V21Ah	36V21Ah
Charging port	DC2.1 Opt. 3Pin high current	
Discharge port	2Pin Opt. 5Pin	
LED indicator	4 LED lights	
USB port	with	
Power switch	without	
L1-L2 (mm)	457x363	392x298

Down tube

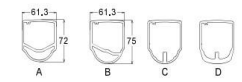
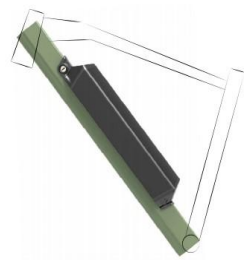

YTK CO.,LTD.  
[Http://www.ytk-group.co.jp](http://www.ytk-group.co.jp)

Model:ID-MINI

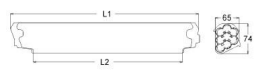

Model	ID-MINI	
Maximum cells	40 (18650)	30 (18650)
Max capacity	36V14Ah	36V10.5Ah
Charging port	DC2.1 Opt. 3Pin high current	
Discharge port	2Pin Opt. 5Pin	
LED indicator	single LED with three colours	
USB port	with	
Power switch	without	
L1-L2 (mm)	458x363	393x298

Down tube

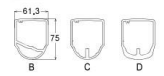

Model:ID-PRO

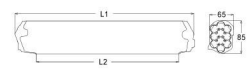

Model	ID-PRO	
Maximum cells	50 (18650)	40 (18650)
Max capacity	36V17.5Ah	36V14Ah
Charging port	DC2.1 Opt. 3Pin high current	
Discharge port	2Pin Opt. 5Pin	
LED indicator	single LED with three colours	
USB port	with	
Power switch	without	
L1-L2 (mm)	458x363	393x298

Down tube

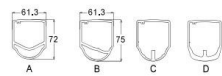

Model:ID-PLUS

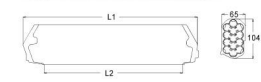

Model	ID-PLUS	
Maximum cells	65 (18650)	52 (18650)
Max capacity	36V21Ah 48V17.5Ah	36V17.5Ah 48V14Ah
Charging port	DC2.1 Opt. 3Pin high current	
Discharge port	2Pin Opt. 5Pin	
LED indicator	4 LED lights	
USB port	with	
Power switch	without	
L1-L2 (mm)	456.5x363	391.5x298

Down tube

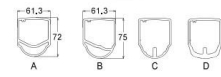
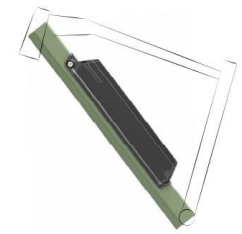



# E-bike Battery (Inner Battery Series) TC-SOUTH PACIFIC 4



MSDS

UN38.3



FC

CE



Model	SP4-T
Maximum cells	40(18650)
Max capacity	36V14Ah/48V10.5Ah
Charging port	Dual DC2.1 port
Discharge port	6pin
LED indicator	Single led indicator (3colours)
USB port	without
Power switch	with
L1·L2 (mm)	420*68*86

Model:SP4-T  
T:up-take style

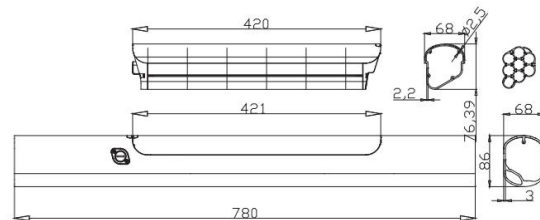

Model:SP4-U  
U:down-take style

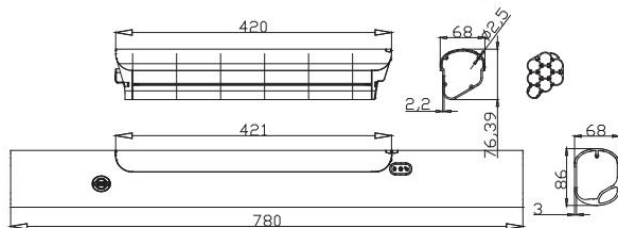

Model	SP4-U
Maximum cells	40(18650)
Max capacity	36V14Ah/48V10.5Ah
Charging port	Dual DC2.1 port
Discharge port	6pin
LED indicator	Single led indicator (3colours)
USB port	without
Power switch	with
L1·L2 (mm)	420*68*86

# E-bike Battery (Inner Battery Series) TC-SOUTH PACIFIC 4 PRO



MSDS

UN38.3



Model	SP4P-T
Maximum cells	65(18650)
Max capacity	36V21Ah/48V17.5Ah
Charging port	Dual DC2.1 port
Discharge port	6pin
LED indicator	Single led indicator (3colours)
USB port	without
Power switch	with
L1·L2 (mm)	487*68*105.7

Model:SP4P-T  
T:UP-take style

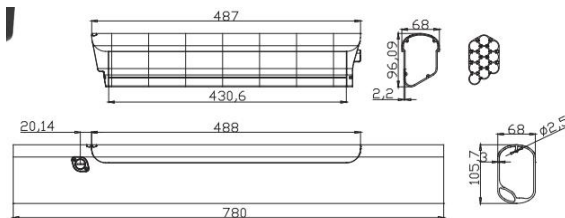

Model:SP4P-U  
U:down-take style

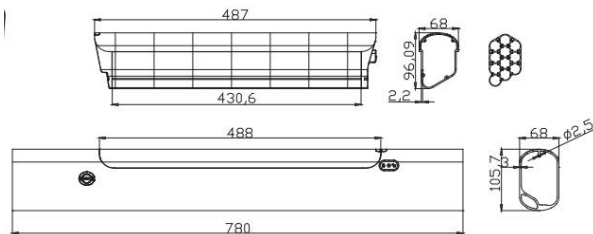

Model	SP4P-U
Maximum cells	65 (18650)
Max capacity	36V21Ah/48V17.5Ah
Charging port	Dual DC2.1 port
Discharge port	6pin
LED indicator	Single led indicator (3colours)
USB port	without
Power switch	with
L1·L2 (mm)	487*68*105.7



# E-bike Battery (Inner Battery Series) TC-NAHAI 1



MSDS

UN38.3



Model	NH-1
Maximum cells	52(18650)
Max capacity	36V17.5Ah/48V14Ah
Charging port	DC2.1 port
Discharge port	5pin
LED indicator	5 level led capacity indicator
USB port	without
Power switch	with
L1·L2 (mm)	454.8*75.1*71.6

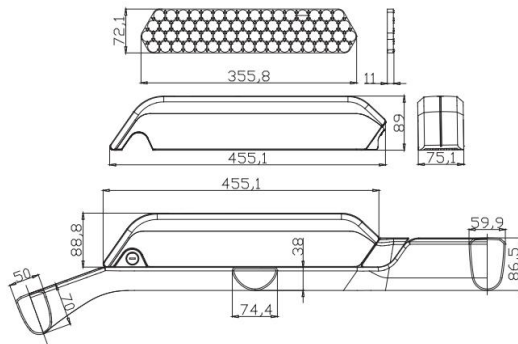
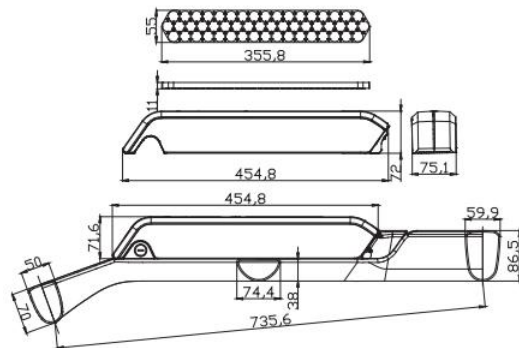

Model	NH-2
Maximum cells	65(18650)
Max capacity	36V21Ah/48V17.5Ah
Charging port	DC2.1 port
Discharge port	5pin
LED indicator	5 level led capacity indicator
USB port	without
Power switch	with
L1·L2 (mm)	455.1*75.1*89

# E-bike Battery (Inner Battery Series) TC-HIER



MSDS

UN38.3



Model:HR-1

Model	HR-1
Maximum cells	30(18650)
Max capacity	36V10.5Ah
Charging port	DC2.1 Port
Discharge port	6pin
LED indicator	5Level led capacity indica tor
USB port	without
Power switch	without
L1·L2 (mm)	84*60.5*407

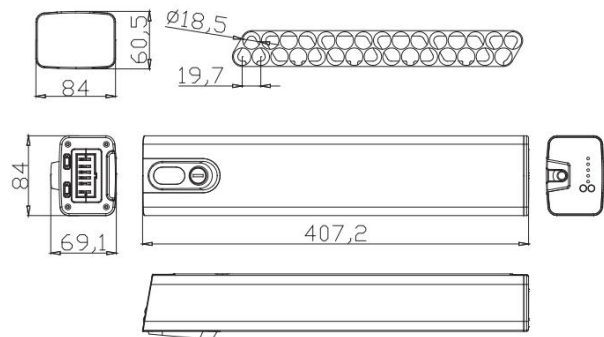

Model	HR-G30
Maximum cells	30(18650)
Max capacity	36V10.5Ah
Charging port	DC2.1 Port
Discharge port	4pin
LED indicator	without
USB port	without
Power switch	without
L1·L2 (mm)	56*602.5



Model:HR-G30

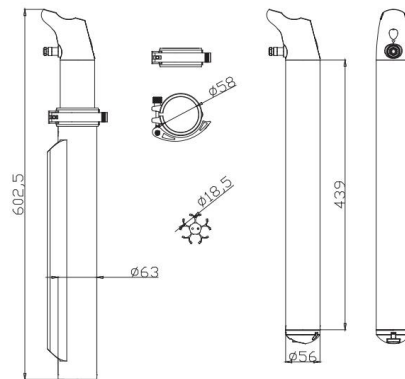



# E-bike Battery (Down tube battery series) TC-KIRIN



MSDS

UN38.3



Model	DK-5-T	DK-5-B
Maximum cells	52 (18650)	
Max capacity	36V17.5Ah 48V14Ah	
Charging port	DC2.1 Opt. 3Pin high current	
Discharge port	6Pin	
LED indicator	4 LED lights	
USB port	without	
Power switch	without	
matched DT	with	without
normal base	without	with
L-W-H (mm)	526x79x72	526x79x87
Optional parts	Aluminum alloy controller box ALU0126	

## Model:DK-5-T

T means the lower pipe of the frame is equipped, and there is no plastic guide plate

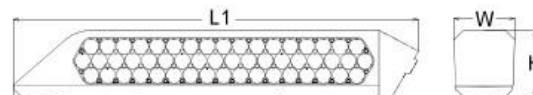

Model:DK-5-B B refers to the base with plastic guide plate



## Model:DK-7

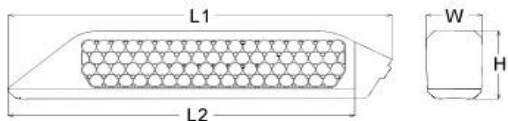

Model:DK-7-B B refers to the base with plastic guide plate



## Model:DK-7-T

T means the lower pipe of the frame is equipped, and there is no plastic guide plate



YTK CO.,LTD.  
[Http://www.ytk-group.co.jp](http://www.ytk-group.co.jp)

Model	DK-7-T	DK-7-B
Maximum cells	70 (18650) & 42 (21700)	
Max capacity	36V24.5Ah 48V17.5Ah	36V20Ah 48V15Ah
Charging port	DC2.1 Opt. 3Pin high current	
Discharge port	6Pin	
LED indicator	4 LED lights	
USB port	without	
Power switch	without	
matched DT	with	without
normal base	without	with
L-W-H (mm)	526x79x90	526x79x104
Optional parts	Aluminum alloy controller box ALU0126	



# E-bike Battery (Down tube battery series) TC-POLLY



MSDS

UN38.3



Model	DP-5C	DP-5	DP-6C	DP-6	DP-9C	DP-9
Maximum cells	52 (18650)	56 (18650)	65 (18650)	70 (18650)	84 (18650)	91 (18650)
Max capacity	36V17.5Ah 48V14Ah	36V17.5Ah 48V14Ah 52V14Ah	36V21Ah 48V17.5Ah	36V24.5Ah 48V17.5Ah 52V17.5Ah	36V28Ah 48V21Ah 52V21Ah	36V31.5Ah 48V24.5Ah
Charging port	DC2.1 Opt. 3Pin high current					
Discharge port	4Pin	5Pin	4Pin	5Pin	4Pin	5Pin
LED indicator	4 LED lights					
USB port	without					
Power switch	with					
Controller box*	with	without	with	without	with	without
L·W·H (mm)	368x90x96		368x90x113		368x90x141	
Optional parts	base block PLA0288		switch hole cover PLA0187		spring lock SDP0017	

\*Can fit 9 mosfets controller PCB

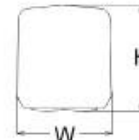
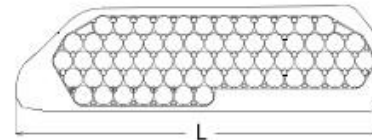

Bottom view with controller, C in model



Bottom view without controller

Model:DP-5/5C



Model:DP-2170-4C



Model:DP-6/6C



Model:DP-9/9C



Model:DP-2170-5C





# E-bike Battery (Down tube battery series) TC-TIGER SHARK



MSDS

UN38.3



Model:DS-4



Model:DS-4C



Model:DS-6



Model:DS-6C



Model:DS-5



Model:DS-5C



Model	DS-4	DS-4C	DS-5	DS-5C	DS-6	DS-6C
Maximum cells	40 (18650)		52 (18650)		65 (18650)	
Max capacity	36V14Ah		36V17.5Ah 48V14Ah		36V21Ah 48V17.5Ah	
Charging port	DC2.1 Opt. 3Pin high current					
Discharge port	2Pin Opt. 5Pin					
LED indicator	4 LED lights					
USB port	with					
Power switch	with					
Controller box*	without	with	without	with	without	with
L·W·H (mm)	343x78x99	378x78x99	343x78x114	378x78x114	343x78x132	378x78x132
Optional parts	base block PLA0288			switch hole cover PLA0187		



YTK CO.,LTD.  
[Http://www.ytk-group.co.jp](http://www.ytk-group.co.jp)

\*Can fit 9 mosfets controller PCB



# E-bike Battery (Down tube battery series) TC-CUTTLE



MSDS

UN38.3



Model	DC-1C	DC-2C
Maximum cells	14 (18650)	21 (18650)
Max capacity	24V7Ah	24V10.5Ah 36V7Ah
Charging port	DC2.1 Opt. 3Pin high current	
Discharge port	2Pin	
LED indicator	single LED with three colours	
USB port	with	
Power switch	without	
Controller box*	with	
L1·L2 (mm)	257x144	326x214
Optional parts	spring lock SDP0028 base block PLA0288	

\*Can fit 6 mosfets controller PCB

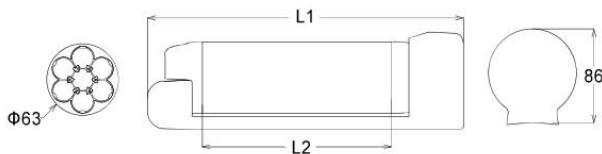

Model:DC-1C



Model:DC-2C



Model:DC-2170-1C



Model:DC-2170-2C

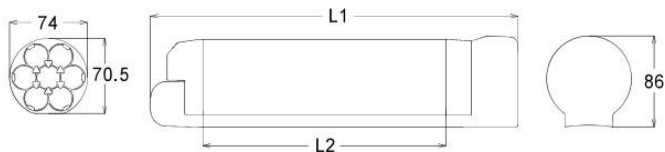

Model	DC-21700	
Maximum cells	14 (21700)	21 (21700)
Max capacity	24V10Ah	24V15Ah 36V10Ah
Charging port	DC2.1 Opt. 3Pin high current	
Discharge port	6Pin	
LED indicator	single LED with three colours	
USB port	with	
Power switch	without	
Controller box*	with	
L1·L2 (mm)	277x160	347x230
Optional parts	spring lock SDP0028 base block PLA0288	

\*Can fit 6 mosfets controller PCB





# E-bike Battery (Seat tube battery series) TC-Silverfish



MSDS

UN38.3

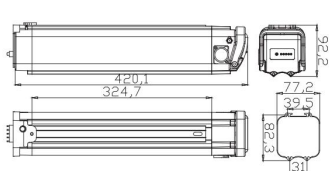

Model	SV-YSL010
Maximum cells	60(18650)
Max capacity	36V21Ah / 48V14Ah
Charging port	3pin cannon
Discharge port	4pin
LED indicator	3LED lights
USB port	without
Power switch	have
L1-L2 (mm)	77.2*92.2*420.1

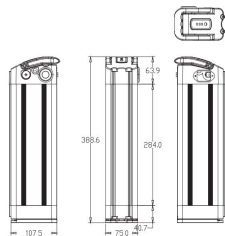

Model	SV-USB012
Maximum cells	65(18650)
Max capacity	36V21Ah / 48V17.5Ah
Charging port	3pin cannon
Discharge port	4pin
LED indicator	3LED lights
USB port	without
Power switch	without
L1-L2 (mm)	107.5*95*388.6

Model:SV-YSL010



YSL: on behalf of Israel

Model:SV-USB012



USB: discharge with USB interface

Model:SV-LD014



LD: represents lower discharge

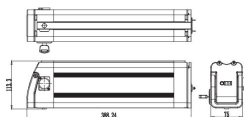

Model	SV-LD014
Maximum cells	65(18650)
Max capacity	36V21Ah / 48V17.5Ah
Charging port	3pin cannon
Discharge port	4pin
LED indicator	3LED lights
USB port	without
Power switch	without
L1-L2 (mm)	113.3*75*388.24

Model:SV-UD015



UD: represents upper discharge

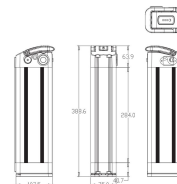

Model	SV-UD015
Maximum cells	65(18650)
Max capacity	36V21Ah / 48V17.5Ah
Charging port	RCA
Discharge port	3pin
LED indicator	3LED lights
USB port	without
Power switch	without
L1-L2 (mm)	107*75*388.6

# E-bike Battery (Rack battery series) TC-BRILLIANCE



MSDS

UN38.3

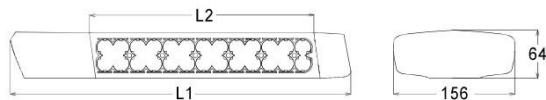

Model:RB-1



Model:RB-1

Model:RB-1-PLUS



Model:RB-2



Model:RB-3

Model	RB-1	RB-2	RB-3	RB-1-PLUS
Maximum cells		52 (18650)		60 (18650)
Max capacity		36V17.5Ah 48V14Ah		36V21Ah 48V14Ah
Charging port	DC2.1 Opt. 3Pin high current			
Discharge port	6Pin			
LED indicator	4 LED lights	without	3LED lights	4 LED lights
USB port	without			
Power switch	with			
Controller space	with			without
Rear light	with	without	with	
L1-L2(mm)	446x278	438x278	438x278	425x320

# E-bike Battery (Rack battery series) TC-HAITIAN 1

Model	HT-1
Maximum cells	40(18650)
Max capacity	36V14Ah/48V10.5Ah
Charging port	DC2.1 port
Discharge port	4pin
LED indicator	4 level led capacity indicator
USB port	without
Power switch	with
L1-L2 (mm)	414.5*138.2*68



Model:HT-1

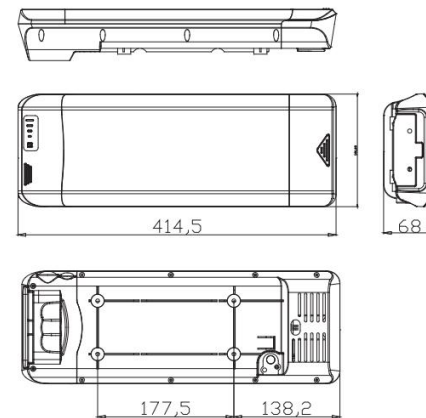

# E-bike Battery (Rack battery series) TC-SOLAR IMPULSE



MSDS

UN38.3



Model	SL-1(SL-2)
Maximum cells	52(18650)
Max capacity	36V17.5Ah/48V14Ah
Charging port	DC2.1 port
Discharge port	5pin
LED indicator	5 level led capacity indicator
USB port	without
Power switch	with
L1-L2 (mm)	431*157.3*50.7(452.8*158.9*51.4)



Model:SL-1

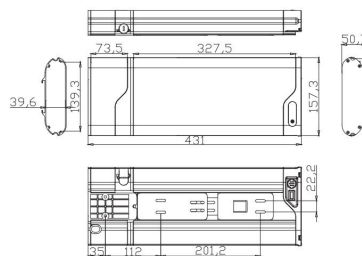

Model:SL-2

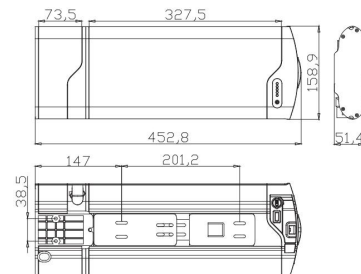

# E-bike Battery (Rack battery series) TC-ULTRA SLIM

Model	US-071
Maximum cells	30(18650)
Max capacity	36V10.5Ah/48V7Ah
Charging port	DC2.1 port
Discharge port	5pin
LED indicator	5 level led capacity indicator
USB port	without
Power switch	with
L1-L2 (mm)	431*156*34.2



Model:US-071

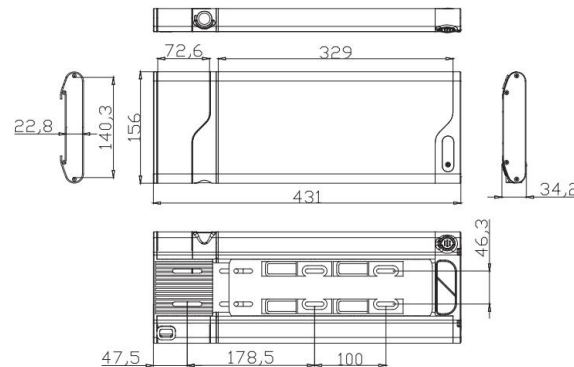

# E-bike Battery (Rack battery series) TC-HAIBAO



MSDS

UN38.3



Model:HB-1

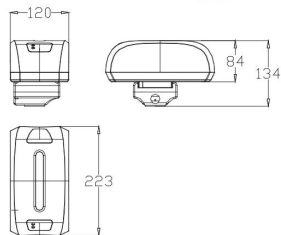

Model:HB-1-2

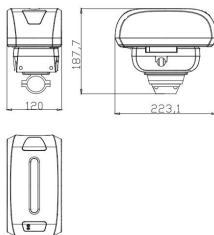

Model	HB-1 (HB-1-2)
Maximum cells	40(18650)
Max capacity	36V14Ah/48V10.5Ah
Charging port	DC2.1 port
Discharge port	2pin
LED indicator	5 level led capacity indicator
USB port	without
Power switch	with
L1-L2 (mm)	223*120*134 (223.1*120*187.7)

Model	HB-2
Maximum cells	40(18650)
Max capacity	36V14Ah/48V10.5Ah
Charging port	DC2.1 port
Discharge port	4pin
LED indicator	4 level led capacity indicator
USB port	without
Power switch	with
L1-L2 (mm)	359.5*147.2*59.6

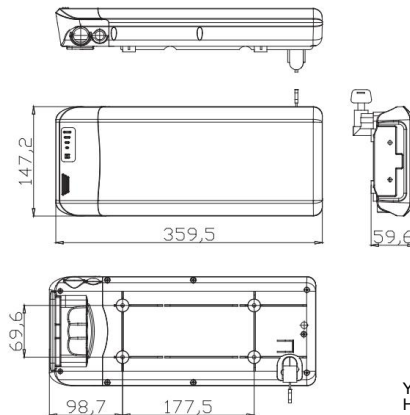

Model:HB-2