

PVC圆形预绝缘端头(TO-JTK型)

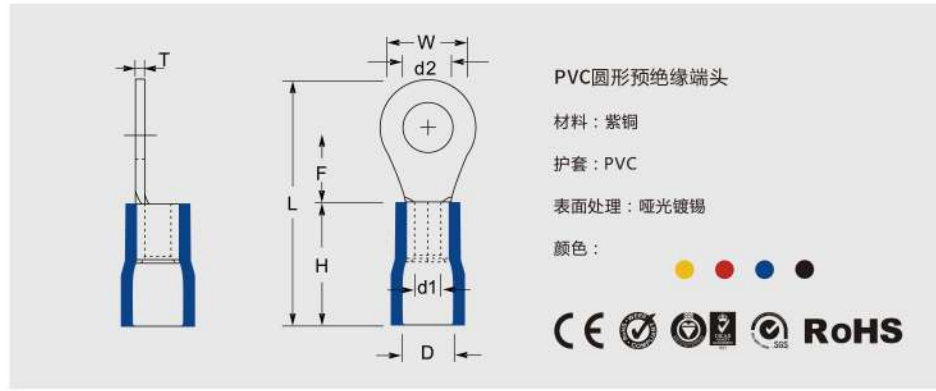

型号 ITEM NO.	STUD SIZE 螺栓口直径 美制螺栓号		尺寸 DIMENSION mm								包装 PCS/ PACK	颜色 COLOR	使用工具 USE THE TOOLS	说明 EXPLANATION	
	Metric	American	d2	W	F	L	H	d1	D	T					
WOV0.5-2	2	#2	2.2										黄 Yellow	SN-02C	端头材质: 紫铜 绝缘材质: PVC 导线截面: 0.2-0.5mm ² 最大电流: I _{max} =9A 最大耐温: 75°C Wire range: 0.2-0.5mm ² A. W. G.: (26-22) Max.current=9A
WOV0.5-2.7	2.5	#3	2.7	5.0	6.0	17.0									
WOV0.5-3.2	3	#4	3.2				8.5	1.2	2.5	0.5	1000				
WOV0.5-3.7	3.5	#6	3.7	6.0	8.0	19.5									
WOV0.5-4	4	#8	4.3	6.5	8.0	19.8									
WOV0.5-5	5	#10	5.3	8.0	8.0	20.5									
WOV1.25-3.2	3	#4	3.2	5.7	4.95	17.8						红 Red	HX-30J AN-30J AP-30J FSB-054YJ	端头材质: 紫铜 绝缘材质: PVC 导线截面: 0.5-1.5mm ² 最大电流: I _{max} =19A 最大耐温: 75°C Wire range: 0.5-1.5mm ² A. W. G.: (22-16) Max.current=19A	
WOV1.25-3.7S	3.5	#6	3.7												
WOV1.25-3.7M	3.5	#6	3.7	6.6	6.3	19.6									
WOV1.25-3.7L	3.5	#6	3.7	8.0	7.0	21.0									
WOV1.25-4S	4	#8	4.3	6.6	6.3	19.6									
WOV1.25-4L	4	#8	4.3	8.0	7.0	21.0	10.0	1.8	4.2	0.8	1000				
WOV1.25-5	5	#10	5.3	9.5	7.5	22.3									
WOV1.25-6	6	1/4"	6.5	11.6	11.2	27.0									
WOV1.25-8	8	5/16"	8.5												
WOV1.25-8L	8	5/16"	8.5	13.6	13.9	30.7									
WOV1.25-10	10	3/8"	10.5												
WOV1.25-12	12	1/2"	13.0	19.2	16.0	35.6	10.0	1.8	4.2	0.8	500				
WOV1.25-14	14	9/16"	15.0												
WOV1.25-16	16	5/8"	17.0	27.0	21.0	44.5	10.0	1.8	4.2	0.8	250				
WOV1.25-20	20	3/4"	21.0												
WOV2-3.2S	3	#4	3.2	5.5	4.8	17.6						蓝 Blue	HX-30J AN-30J AP-30J FSB-054YJ	端头材质: 紫铜 绝缘材质: PVC 导线截面: 1.5-2.5mm ² 最大电流: I _{max} =27A 最大耐温: 75°C Wire range: 1.5-2.5mm ² A. W. G.: (16-14) Max.current=27A	
WOV2-3.2	3	#4	3.2	6.6	6.4	19.7									
WOV2-3.7	3.5	#6	3.7												
WOV2-3.7M	3.5	#6	3.7	6.6	7.9	21.2									
WOV2-3.7L	3.5	#6	3.7	8.5	7.75	22.0									
WOV2-4S	4	#8	4.3	6.6	7.9	21.2									
WOV2-4L	4	#8	4.3	8.5	7.75	22.0	10.0	2.4	4.7	0.8	1000				
WOV2-5S	5	#10	5.3												
WOV2-5L	5	#10	5.3	9.5	7.5	22.3									
WOV2-6	6	1/4"	6.5	12.0	11.0	27.0									

PVC圆形预绝缘端头(TO-JTK型)

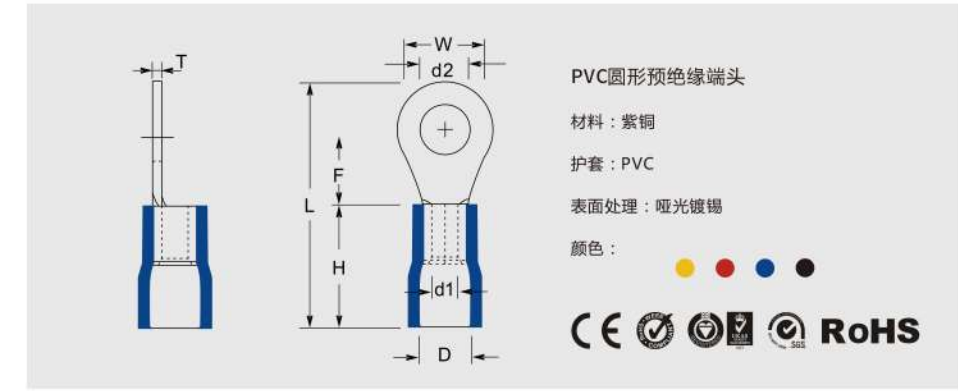

型号 ITEM NO.	STUD SIZE 螺栓口直径 美制螺栓号		尺寸 DIMENSION mm								包装 PCS/ PACK	颜色 COLOR	使用工具 USE THE TOOLS	说明 EXPLANATION	
	Metric	American	d2	W	F	L	H	d1	D	T					
WOV2-8	8	5/16"	8.5	12.0	11.0	27.0							蓝 Blue	HX-30J AN-30J AP-30J FSB-054YJ	端头材质: 紫铜 绝缘材质: PVC 导线截面: 1.5-2.5mm ² 最大电流: I _{max} =27A 最大耐温: 75°C Wire range: 1.5-2.5mm ² A. W. G.: (16-14) Max.current=27A
WOV2-8L	8	5/16"	8.5	13.6	13.9	30.7	10.0	2.4	4.7	0.8	1000				
WOV2-10	10	3/8"	10.5												
WOV2-12	12	1/2"	13.0	19.2	16.0	35.6	10.0	2.4	4.7	0.8	500				
WOV2-14	14	9/16"	15.0												
WOV2-16	16	5/8"	17.0	27.0	21.0	44.5	10.0	2.4	4.7	0.8	250				
WOV2-20	20	3/4"	21.0												
WOV3.5-4	4	#8	4.3	8.0	7.7	24.7						黑 Black	HX-30J AN-30J AP-30J FSB-054YJ	端头材质: 紫铜 绝缘材质: PVC 导线截面: 2.5-4mm ² 最大电流: I _{max} =37A 最大耐温: 75°C Wire range: 2.5-4mm ² A. W. G.: (14-12) Max.current=37A	
WOV3.5-5S	5	#10	5.3												
WOV3.5-5L	5	#10	5.3	12.0	9.4	28.4									
WOV3.5-6	6	1/4"	6.5	15.0	13.5	34.0	13.0	3.0	6.2	1.0	500				
WOV3.5-8	8	5/16"	8.5												
WOV3.5-10	10	3/8"	10.5	19.2	16.0	38.6									
WOV3.5-12	12	1/2"	13.0	19.2	16.0	38.6									
WOV5.5-3.2	3.0	#4	3.2									黄 Yellow	HX-30J AN-30J AP-30J FSB-054YJ	端头材质: 紫铜 绝缘材质: PVC 导线截面: 4-6mm ² 最大电流: I _{max} =48A 最大耐温: 75°C Wire range: 4-6mm ² A. W. G.: (12-10) Max.current=48A	
WOV5.5-3.7	3.5	#6	3.7	7.2	5.9	22.5									
WOV5.5-4S	4	#8	4.3												
WOV5.5-4L	4	#8	4.3	9.5	8.85	26.6									
WOV5.5-5	5	#10	5.3												
WOV5.5-6	6	1/4"	6.5	12.0	10.5	29.5									
WOV5.5-6M	6	1/4"	6.5		13.0	32.0									
WOV5.5-8	8	5/16"	8.5	15.0	13.5	34.0	13.0	3.5	6.5	1.0	500				
WOV5.5-10	10	3/8"	10.5												
WOV5.5-12	12	1/2"	13.0	19.2	16.0	38.6									
WOV5.5-14	14	9/16"	15.0												
WOV5.5-16	16	5/8"	17.0	32.0	25.2	54.2	13.0	3.5	6.5	1.0	250				
WOV5.5-20	20	3/4"	21.0												

PVC叉形预绝缘端头(TU-JTK型)

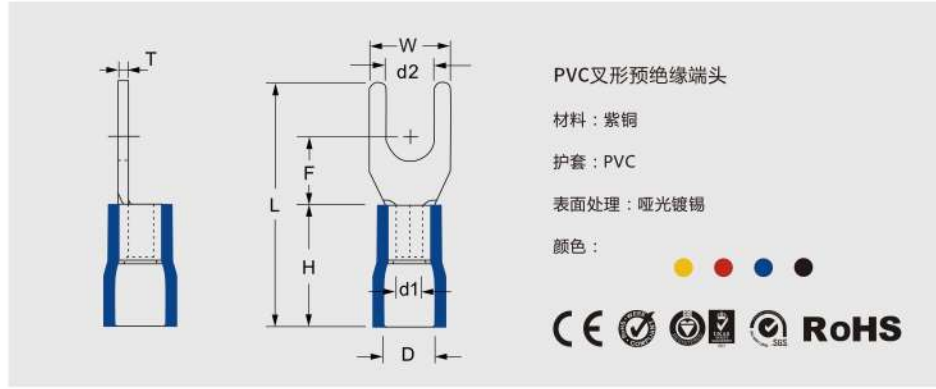

型号 ITEM NO.	STUD SIZE 螺栓口直径 美制螺栓号		尺寸 DIMENSION mm								包装 PCS/ PACK	颜色 COLOR	使用工具 USE THE TOOLS	说明 EXPLANATION
	Metric	American	d2	W	F	L	H	d1	D	T				
WYV0.5-2	2	#2	2.2	5.0	4.5	17.0	8.5	1.2	2.5	0.5	1000	黄 Yellow	SN-02C	端头材质: 紫铜 绝缘材质: PVC 导线截面: 0.2-0.5mm ² 最大电流: I _{max} =9A 最大耐温: 75°C Wire range : 0.2-0.5mm ² A. W. G. : (26-22) Max.current=9A
WYV0.5-3.2	3	#4	3.2											
WYV0.5-3.7	3.5	#6	3.7											
WYV0.5-4	4	#8	4.3	7.0	20.2	8.5	1.2	2.5	0.5	1000	黄 Yellow	SN-02C	端头材质: 紫铜 绝缘材质: PVC 导线截面: 0.2-0.5mm ² 最大电流: I _{max} =9A 最大耐温: 75°C Wire range : 0.2-0.5mm ² A. W. G. : (26-22) Max.current=9A	
WYV0.5-5	5	#10	5.3											
WYV1.25-3.2	3	#4	3.2											
WYV1.25-3.7S	3.5	#6	3.7	5.7	7.0	20.2	8.5	1.2	2.5	0.5	1000	黄 Yellow	SN-02C	端头材质: 紫铜 绝缘材质: PVC 导线截面: 0.2-0.5mm ² 最大电流: I _{max} =9A 最大耐温: 75°C Wire range : 0.2-0.5mm ² A. W. G. : (26-22) Max.current=9A
WYV1.25-3.7L	3.5	#6	3.7											
WYV1.25-3.7LL	3.5	#6	3.7											
WYV1.25-4S	4	#8	4.3	6.5	21.2	10.0	1.8	4.2	0.8	1000	红 Red	HX-30J AN-30J AP-30J FSB-054YJ	端头材质: 紫铜 绝缘材质: PVC 导线截面: 0.5-1.5mm ² 最大电流: I _{max} =19A 最大耐温: 75°C Wire range : 0.5-1.5mm ² A. W. G. : (22-16) Max.current=19A	
WYV1.25-4M	4	#8	4.3											
WYV1.25-4L	4	#8	4.3											
WYV1.25-5S	5	#10	5.3	8.1	6.5	21.2	10.0	1.8	4.2	0.8	1000	红 Red	HX-30J AN-30J AP-30J FSB-054YJ	端头材质: 紫铜 绝缘材质: PVC 导线截面: 0.5-1.5mm ² 最大电流: I _{max} =19A 最大耐温: 75°C Wire range : 0.5-1.5mm ² A. W. G. : (22-16) Max.current=19A
WYV1.25-5L	5	#10	5.3											
WYV1.25-6S	6	1/4"	6.5											
WYV1.25-6L	6	1/4"	6.5	12.0	11.0	27.2	10.0	2.4	4.7	0.8	1000	蓝 Blue	HX-30J AN-30J AP-30J FSB-054YJ	端头材质: 紫铜 绝缘材质: PVC 导线截面: 1.5-2.5mm ² 最大电流: I _{max} =27A 最大耐温: 75°C Wire range : 1.5-2.5mm ² A. W. G. : (16-14) Max.current=27A
WYV1.25-8	8	5/16"	8.5											
WYV2-3.2	3	#4	3.2											
WYV2-3.7S	3.5	#6	3.7	5.7	7.0	20.2	8.5	1.2	2.5	0.5	1000	黄 Yellow	SN-02C	端头材质: 紫铜 绝缘材质: PVC 导线截面: 0.2-0.5mm ² 最大电流: I _{max} =9A 最大耐温: 75°C Wire range : 0.2-0.5mm ² A. W. G. : (26-22) Max.current=9A
WYV2-3.7L	3.5	#6	3.7											
WYV2-3.7LL	3.5	#6	3.7											
WYV2-4S	4	#8	4.3	6.5	21.2	10.0	1.8	4.2	0.8	1000	红 Red	HX-30J AN-30J AP-30J FSB-054YJ	端头材质: 紫铜 绝缘材质: PVC 导线截面: 0.5-1.5mm ² 最大电流: I _{max} =19A 最大耐温: 75°C Wire range : 0.5-1.5mm ² A. W. G. : (22-16) Max.current=19A	
WYV2-4M	4	#8	4.3											
WYV2-4L	4	#8	4.3											
WYV2-5S	5	#10	5.3	8.1	6.5	21.2	10.0	1.8	4.2	0.8	1000	红 Red	HX-30J AN-30J AP-30J FSB-054YJ	端头材质: 紫铜 绝缘材质: PVC 导线截面: 0.5-1.5mm ² 最大电流: I _{max} =19A 最大耐温: 75°C Wire range : 0.5-1.5mm ² A. W. G. : (22-16) Max.current=19A
WYV2-5L	5	#10	5.3											
WYV2-6S	6	1/4"	6.5											
WYV2-6L	6	1/4"	6.5	12.0	11.0	27.2	10.0	2.4	4.7	0.8	1000	蓝 Blue	HX-30J AN-30J AP-30J FSB-054YJ	端头材质: 紫铜 绝缘材质: PVC 导线截面: 1.5-2.5mm ² 最大电流: I _{max} =27A 最大耐温: 75°C Wire range : 1.5-2.5mm ² A. W. G. : (16-14) Max.current=27A
WYV2-8	8	5/16"	8.5											

PVC叉形预绝缘端头(TU-JTK型)

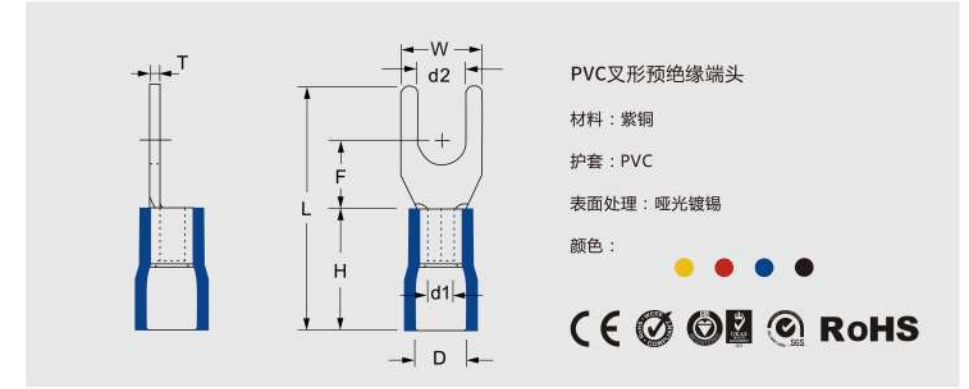

型号 ITEM NO.	STUD SIZE 螺栓口直径 美制螺栓号		尺寸 DIMENSION mm								包装 PCS/ PACK	颜色 COLOR	使用工具 USE THE TOOLS	说明 EXPLANATION
	Metric	American	d2	W	F	L	H	d1	D	T				
WYV3.5-3.7	3.5	#6	3.7	8.0	7.7	25.3	13.0	3.0	6.2	1.0	500	黑 Black	HX-30J AN-30J AP-30J FSB-054YJ	端头材质: 紫铜 绝缘材质: PVC 导线截面: 2.5-4mm ² 最大电流: I _{max} =37A 最大耐温: 75°C Wire range : 2.5-4mm ² A. W. G. : (14-12) Max.current=37A
WYV3.5-4	4.0	#8	4.3											
WYV3.5-5	5.0	#10	5.3											
WYV3.5-6	6.0	1/4"	6.5	12.0	9.1	28.5	13.0	3.0	6.2	1.0	500	黑 Black	HX-30J AN-30J AP-30J FSB-054YJ	端头材质: 紫铜 绝缘材质: PVC 导线截面: 2.5-4mm ² 最大电流: I _{max} =37A 最大耐温: 75°C Wire range : 2.5-4mm ² A. W. G. : (14-12) Max.current=37A
WYV3.5-8	8	5/16"	8.5											
WYV3.5-10	10	3/8"	10.5											
WYV5.5-3.7S	3.5	#6	3.7	7.2	7.5	24.4	13.0	3.5	6.5	1.0	500	黄 Yellow	HX-30J AN-30J AP-30J FSB-054YJ	端头材质: 紫铜 绝缘材质: PVC 导线截面: 4-6mm ² 最大电流: I _{max} =48A 最大耐温: 75°C Wire range : 4-6mm ² A. W. G. : (12-10) Max.current=48A
WYV5.5-3.7	3.5	#6	3.7											
WYV5.5-4SSS	4	#8	4.3											
WYV5.5-4SS	4	#8	4.3	7.2	7.5	24.4	13.0	3.5	6.5	1.0	500	黄 Yellow	HX-30J AN-30J AP-30J FSB-054YJ	端头材质: 紫铜 绝缘材质: PVC 导线截面: 4-6mm ² 最大电流: I _{max} =48A 最大耐温: 75°C Wire range : 4-6mm ² A. W. G. : (12-10) Max.current=48A
WYV5.5-4S	4	#8	4.3											
WYV5.5-4L	4	#8	4.3											
WYV5.5-5	5	#10	5.3	9.0	7.0	25.5	13.0	3.5	6.5	1.0	500	黄 Yellow	HX-30J AN-30J AP-30J FSB-054YJ	端头材质: 紫铜 绝缘材质: PVC 导线截面: 4-6mm ² 最大电流: I _{max} =48A 最大耐温: 75°C Wire range : 4-6mm ² A. W. G. : (12-10) Max.current=48A
WYV5.5-6S	6	1/4"	6.5											
WYV5.5-6L	6	1/4"	6.5											
WYV5.5-8	8	5/16"	8.5	14.0	11.5	30.7	13.0	3.5	6.5	1.0	500	黄 Yellow	HX-30J AN-30J AP-30J FSB-054YJ	端头材质: 紫铜 绝缘材质: PVC 导线截面: 4-6mm ² 最大电流: I _{max} =48A 最大耐温: 75°C Wire range : 4-6mm ² A. W. G. : (12-10) Max.current=48A
WYV5.5-10	10	3/8"	10.5											

PVC锁扣叉形预绝缘端头



PVC锁扣叉形预绝缘端头
 材料：紫铜
 护套：PVC
 表面处理：哑光镀锡
 颜色：

CE RoHS

型号 ITEM NO.	STUD SIZE 螺栓口直径 美制螺栓号		尺寸 DIMENSION mm								包装 PCS/ PACK	颜色 COLOR	使用工具 USE THE TOOLS	说明 EXPLANATION
	Metric	American	d2	W	F	L	H	d1	D	T				
WYVSK1.25-3.7	3.5	#6	3.7	6.4	6.5	21.2	10.0	1.8	4.2	0.8	1000	● 红 Red	HX-30J AN-30J AP-30J FSB-054YJ	端头材质:紫铜 绝缘材质:PVC 导线截面:0.5-1.5mm ² 最大电流:I _{max} =19A 最大耐温:75°C Wire range:0.5-1.5mm ² A.W.G.:(22-16) Max.current=19A
WYVSK1.25-4	4	#8	4.3	7.2										
WYVSK1.25-5S	5	#10	5.3	8.1										
WYVSK1.25-5L	5	#10	5.3	9.5										
WYVSK2-3.7S	3.5	#6	3.7	6.0	6.5	21.2	10.0	2.4	4.7	0.8	1000	● 蓝 Blue	HX-30J AN-30J AP-30J FSB-054YJ	端头材质:紫铜 绝缘材质:PVC 导线截面:1.5-2.5mm ² 最大电流:I _{max} =27A 最大耐温:75°C Wire range:1.5-2.5mm ² A.W.G.:(16-14) Max.current=27A
WYVSK2-4	4	#8	4.3	7.2										
WYVSK2-4L	4	#8	4.3	8.1										
WYVSK2-5S	5	#10	5.3	8.1										
WYVSK2-5L	5	#10	5.3	9.5										
WYVSK5.5-3.7	3.5	#6	3.7	8.3	7.0	25.5	13.0	3.5	6.5	1.0	500	● 黄 Yellow	HX-30J AN-30J AP-30J FSB-054YJ	端头材质:紫铜 绝缘材质:PVC 导线截面:4-6mm ² 最大电流:I _{max} =48A 最大耐温:75°C Wire range:4-6mm ² A.W.G.:(12-10) Max.current=48A
WYVSK5.5-4	4	#8	4.3	8.3										
WYVSK5.5-5	5	#10	5.3	9.0										
WYVSK5.5-6	6	1/4"	6.5	12.0										

PVC凸缘叉型预绝缘端头



PVC凸缘叉形预绝缘端头
 材料：紫铜
 护套：PVC
 表面处理：哑光镀锡
 颜色：

CE RoHS

型号 ITEM NO.	STUD SIZE 螺栓口直径 美制螺栓号		尺寸 DIMENSION mm								包装 PCS/ PACK	颜色 COLOR	使用工具 USE THE TOOLS	说明 EXPLANATION
	Metric	American	d2	W	F	L	H	d1	D	T				
WYVTY1.25-3.2	3	#4	3.2	7.5	5.1	19.5	10.0	1.8	4.2	0.8	1000	● 红 Red	HX-30J AN-30J AP-30J FSB-054YJ	端头材质:紫铜 绝缘材质:PVC 导线截面:0.5-1.5mm ² 最大电流:I _{max} =19A 最大耐温:75°C Wire range:0.5-1.5mm ² A.W.G.:(22-16) Max.current=19A
WYVTY1.25-3.7	3.5	#6	3.7											
WYVTY1.25-4	4	#8	4.3											
WYVTY1.25-5	5	#10	5.3											
WYVTY2-3.7	3.5	#6	3.7	7.5	5.2	20.2	10.0	2.4	4.7	0.8	1000	● 蓝 Blue	HX-30J AN-30J AP-30J FSB-054YJ	端头材质:紫铜 绝缘材质:PVC 导线截面:1.5-2.5mm ² 最大电流:I _{max} =27A 最大耐温:75°C Wire range:1.5-2.5mm ² A.W.G.:(16-14) Max.current=27A
WYVTY2-4	4	#8	4.3											
WYVTY2-5	5	#10	5.3											
WYVTY5.5-3.7	3.5	#6	3.7	8.5	7.5	27.0	13.0	3.5	6.5	1.0	500	● 黄 Yellow	HX-30J AN-30J AP-30J FSB-054YJ	端头材质:紫铜 绝缘材质:PVC 导线截面:4-6mm ² 最大电流:I _{max} =48A 最大耐温:75°C Wire range:4-6mm ² A.W.G.:(12-10) Max.current=48A
WYVTY5.5-4	4	#8	4.3											
WYVTY5.5-5	5	#10	5.3											

冷压端子

冷压端子

PVC钩形预绝缘端头(TJ-JTK型)

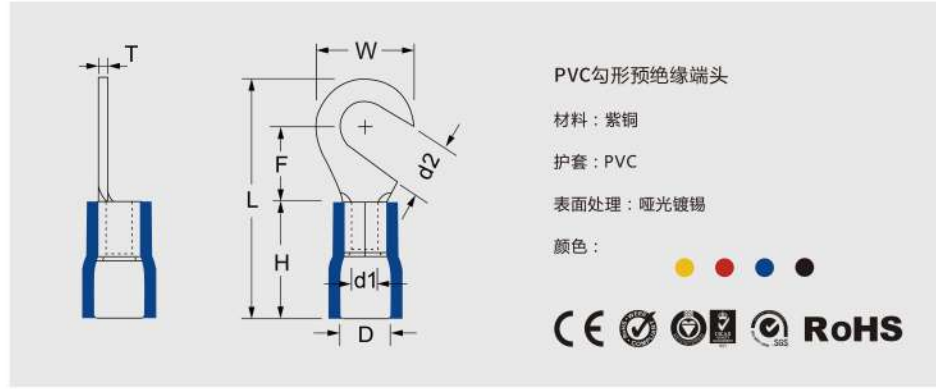

型号 ITEM NO.	STUD SIZE 螺栓口直径 美制螺栓号		尺寸 DIMENSION mm								包装 PCS/ PACK	颜色 COLOR	使用工具 USE THE TOOLS	说明 EXPLANATION
	Metric	American	d2	W	F	L	H	d1	D	T				
WG XV1.25-3.7	3.5	#6	3.7									● 红 Red	HX-30J AN-30J AP-30J FSB-054YJ	端头材质: 紫铜 绝缘材质: PVC 导线截面: 0.5-1.5mm ² 最大电流: I _{max} =19A 最大耐温: 75°C Wire range: 0.5-1.5mm ² A. W. G.: (22-16) Max.current=19A
WG XV1.25-4	4	#8	4.3	8.0	7.0	21.0	10.0	1.8	4.2	0.8				
WG XV1.25-5	5	#10	5.3											
WG XV1.25-6	6	1/4"	6.5	11.6	11.2	27.0								
WG XV2-3.7	3.5	#6	3.7	8.5	7.75	22.0	10.0	2.4	4.7	0.8	1000	● 蓝 Blue	HX-30J AN-30J AP-30J FSB-054YJ	端头材质: 紫铜 绝缘材质: PVC 导线截面: 1.5-2.5mm ² 最大电流: I _{max} =27A 最大耐温: 75°C Wire range: 1.5-2.5mm ² A. W. G.: (16-14) Max.current=27A
WG XV2-4	4	#8	4.3											
WG XV2-5	5	#10	5.3	9.5	7.5	22.3								
WG XV2-6	6	1/4"	6.5	12.0	11.0	27.0								
WG XV5.5-3.7	3.5	#6	3.7	7.2	5.9	22.5	13.0	3.5	6.5	1.0	500	● 黄 Yellow	HX-30J AN-30J AP-30J FSB-054YJ	端头材质: 紫铜 绝缘材质: PVC 导线截面: 4-6mm ² 最大电流: I _{max} =48A 最大耐温: 75°C Wire range: 4-6mm ² A. W. G.: (12-10) Max.current=48A
WG XV5.5-4	4	#8	4.3	9.5	8.85	26.6								
WG XV5.5-5	5	#10	5.3											
WG XV5.5-6	6	1/4"	6.5	12.0	10.5	29.5								
WG XV5.5-8	8	5/16"	8.5	15.0	13.5	34.0								

PVC片形预绝缘端头

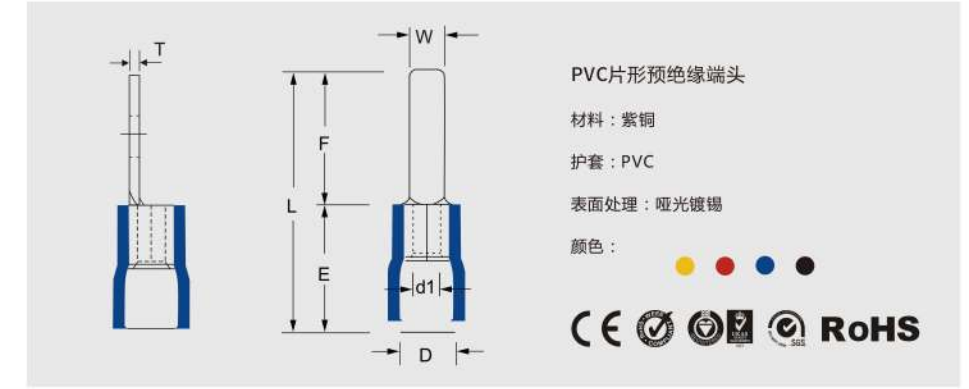

型号 ITEM NO.	尺寸 DIMENSION mm								包装 PCS/ PACK	颜色 COLOR	使用工具 USE THE TOOLS	说明 EXPLANATION
	W	F	L	H	d1	D	T					
WPV 1.25-9	2.8	9.0	19.0	10.0	1.8	4.2	0.8	1000	● 红 Red	HX-30J AN-30J AP-30J FSB-054YJ	端头材质: 紫铜 绝缘材质: PVC 导线截面: 0.5-1.5mm ² 最大电流: I _{max} =19A 最大耐温: 75°C Wire range: 0.5-1.5mm ² A. W. G.: (22-16) Max.current=19A	
WPV 1.25-10	2.3	10.0	20.0									
WPV 1.25-11	3.0	11.0	21.0									
WPV 1.25-13	3.0	13.0	23.0									
WPV 1.25-14	3.0	14.0	24.0									
WPV 1.25-18	2.2	18.0	28.0									
WPV 1.25-18S	2.0											
WPV 2-9	3.0	9.0	19.0	10.0	2.4	4.7	0.8	1000	● 蓝 Blue	HX-30J AN-30J AP-30J FSB-054YJ	端头材质: 紫铜 绝缘材质: PVC 导线截面: 1.5-2.5mm ² 最大电流: I _{max} =27A 最大耐温: 75°C Wire range: 1.5-2.5mm ² A. W. G.: (16-14) Max.current=27A	
WPV 2-10	2.4	10.0	20.0									
WPV 2-13	2.4	13.0	23.0									
WPV 2-13L	3.0											
WPV 2-14	2.4	14.0	24.0									
WPV 2-14L	3.0											
WPV 2-18S	2.0	18.0	28.0									
WPV 2-18L	2.8											
WPV 5.5-10	2.8	10.0	23.0	13.0	3.5	6.5	1.0	500	● 黄 Yellow	HX-30J AN-30J AP-30J FSB-054YJ	端头材质: 紫铜 绝缘材质: PVC 导线截面: 4-6mm ² 最大电流: I _{max} =48A 最大耐温: 75°C Wire range: 4-6mm ² A. W. G.: (12-10) Max.current=48A	
WPV 5.5-14S	4.0	14.0	27.0									
WPV 5.5-14	4.5											
WPV 5.5-18S	2.0	18.0	31.0									
WPV 5.5-18	4.5											

PVC凹片形预绝缘端头

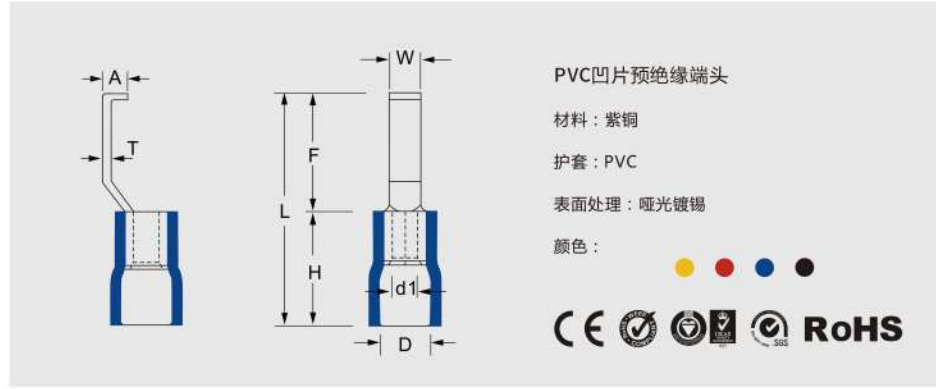

型号 ITEM NO.	尺寸 DIMENSION mm								包装 PCS/ PACK	颜色 COLOR	使用工具 USE THE TOOLS	说明 EXPLANATION
	W	F	L	H	d1	D	T	A				
WPVTY 1.25-3	3.0	17.8	27.8	10.0	1.8	4.2	0.8	2.1	1000	● 红 Red	HX-30J AN-30J AP-30J FSB-054YJ	端头材质:紫铜 绝缘材质:PVC 导线截面:0.5-1.5mm ² 最大电流:Imax=19A 最大耐温:75°C Wire range:0.5-1.5mm ² A.W.G.:(22-16) Max.current=19A
WPVTY 1.25-4.6	4.6											
WPVTY 2-3	3.0	17.8	27.8	10.0	2.4	4.7	0.8	2.1	1000	● 蓝 Blue	HX-30J AN-30J AP-30J FSB-054YJ	端头材质:紫铜 绝缘材质:PVC 导线截面:1.5-2.5mm ² 最大电流:Imax=27A 最大耐温:75°C Wire range:1.5-2.5mm ² A.W.G.:(16-14) Max.current=27A
WPVTY 2-4.6	4.6											
WPVTY 5.5-3	3.0	18.2	31.2	13.0	3.5	6.5	1.0	2.75	500	● 黄 Yellow	HX-30J AN-30J AP-30J FSB-054YJ	端头材质:紫铜 绝缘材质:PVC 导线截面:4-6mm ² 最大电流:Imax=48A 最大耐温:75°C Wire range:4-6mm ² A.W.G.:(12-10) Max.current=48A
WPVTY 5.5-4.6	4.6											

PVC 针形预绝缘端头(TZ-JTK型)

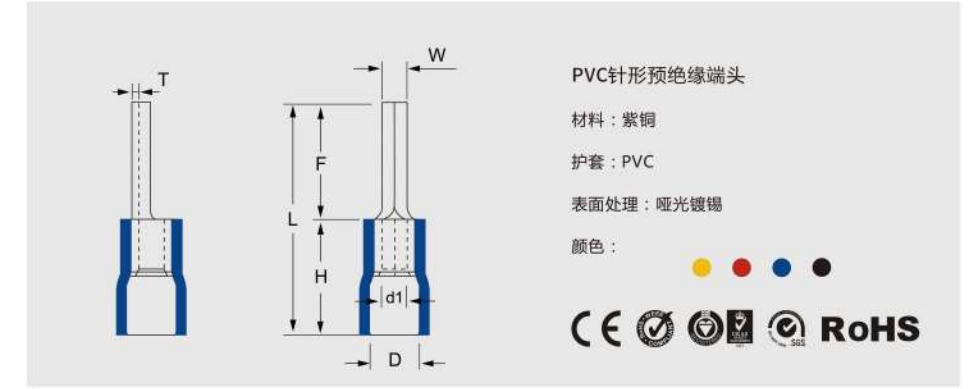

型号 ITEM NO.	尺寸 DIMENSION mm								包装 PCS/ PACK	颜色 COLOR	使用工具 USE THE TOOLS	说明 EXPLANATION
	W	F	L	H	d1	D	T	A				
WZV1.25-9	1.9	9.0	19.0	10.0	1.8	4.2	0.8	1000	● 红 Red	HX-30J AN-30J AP-30J FSB-054YJ	端头材质:紫铜 绝缘材质:PVC 导线截面:0.5-1.5mm ² 最大电流:Imax=19A 最大耐温:75°C Wire range:0.5-1.5mm ² A.W.G.:(22-16) Max.current=19A	
WZV1.25-10		10.0	20.0									
WZV1.25-12		12.0	22.0									
WZV1.25-13		13.0	23.0									
WZV1.25-14		14.0	24.0									
WZV1.25-17		17.0	27.0									
WZV2-9	1.9	9.0	19.0	10.0	2.4	4.7	0.8	1000	● 蓝 Blue	HX-30J AN-30J AP-30J FSB-054YJ	端头材质:紫铜 绝缘材质:PVC 导线截面:1.5-2.5mm ² 最大电流:Imax=27A 最大耐温:75°C Wire range:1.5-2.5mm ² A.W.G.:(16-14) Max.current=27A	
WZV2-10		10.0	20.0									
WZV2-12		12.0	22.0									
WZV2-13		13.0	23.0									
WZV2-17		17.0	27.0									
WZV3.5-13	2.8	13.0	19.0	13.0	3.0	6.2	1.0	500	● 黑 Black	HX-30J AN-30J AP-30J FSB-054YJ	端头材质:紫铜 绝缘材质:PVC 导线截面:2.5-4.5mm ² 最大电流:Imax=37A 最大耐温:75°C Wire range:2.5-4.5mm ² A.W.G.:(14-12) Max.current=37A	
WZV5.5-13	2.8	13.0	26.0	13.0	3.5	6.5	1.0	500	● 黄 Yellow	HX-30J AN-30J AP-30J FSB-054YJ	端头材质:紫铜 绝缘材质:PVC 导线截面:4-6mm ² 最大电流:Imax=48A 最大耐温:75°C Wire range:4-6mm ² A.W.G.:(12-10) Max.current=48A	
WZV5.5-25		25	38									

尼龙圆形预绝缘端头(TO-JTK型)

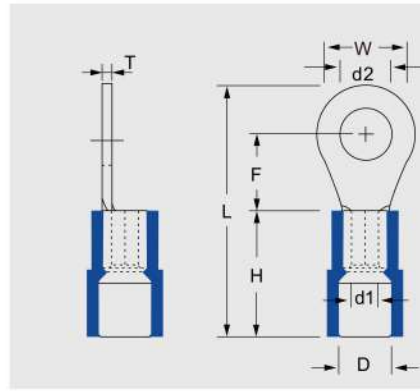

尼龙圆形预绝缘端头

材料: 紫铜

护套: 尼龙

表面处理: 哑光镀锡

颜色:



冷压端子

型号 ITEM NO.	STUD SIZE 螺柱口直径 美制螺柱号		尺寸 DIMENSION mm								包装 PCS/ PACK	颜色 COLOR	使用工具 USE THE TOOLS	说明 EXPLANATION								
	Metric	American	d2	W	F	L	H	d1	D	T												
WOVNN1.25-3.2	3	#4	3.2	5.7	4.95	18.8	11.0	1.8	4.3	0.8	1000	● 红 Red	HX-30J AN-30J AP-30J FSB-054YJ	端头材质: 紫铜 绝缘材质: PA66 导线截面: 0.5-1.5mm ² 最大电流: I _{max} =19A 最大耐温: 105°C Wire range: 0.5-1.5mm ² A. W. G.: (22-16) Max.current=19A								
WOVNN1.25-3.7S	3.5	#6	3.7																			
WOVNN1.25-3.7M	3.5	#6	3.7	6.6	6.3	20.6																
WOVNN1.25-3.7L	3.5	#6	3.7	8.0	7.0	22.0																
WOVNN1.25-4S	4	#8	4.3	6.6	6.3	20.6																
WOVNN1.25-4L	4	#8	4.3	8.0	7.0	22.0																
WOVNN1.25-5	5	#10	5.3	9.5	7.5	23.3																
WOVNN1.25-5L	5	#10	5.3	11.6	11.2	28.0																
WOVNN1.25-6	6	1/4"	6.5	13.6	13.9	31.7																
WOVNN1.25-8	8	5/16"	8.5	19.2	16.0	36.6																
WOVNN1.25-8L	8	5/16"	8.5	27.0	21.0	45.5																
WOVNN1.25-10	10	3/8"	10.5	27.0	21.0	45.5									11.0	2.4	4.8	0.8	1000	● 蓝 Blue	HX-30J AN-30J AP-30J FSB-054YJ	端头材质: 紫铜 绝缘材质: PA66 导线截面: 1.5-2.5mm ² 最大电流: I _{max} =27A 最大耐温: 105°C Wire range: 1.5-2.5mm ² A. W. G.: (16-14) Max.current=27A
WOVNN1.25-12	12	1/2"	13.0																			
WOVNN1.25-14	14	9/16"	15.0																			
WOVNN1.25-16	16	5/8"	17.0																			
WOVNN1.25-20	20	3/4"	21.0																			
WOVNN2-3.2S	3	#4	3.2	5.5	4.8	18.6	11.0	2.4	4.8	0.8	1000	● 蓝 Blue	HX-30J AN-30J AP-30J FSB-054YJ	端头材质: 紫铜 绝缘材质: PA66 导线截面: 1.5-2.5mm ² 最大电流: I _{max} =27A 最大耐温: 105°C Wire range: 1.5-2.5mm ² A. W. G.: (16-14) Max.current=27A								
WOVNN2-3.2	3	#4	3.2	6.6	6.4	20.7																
WOVNN2-3.7	3.5	#6	3.7	6.6	7.9	22.2																
WOVNN2-3.7M	3.5	#6	3.7	8.5	7.75	23.0																
WOVNN2-3.7L	3.5	#6	3.7	8.5	7.75	23.0																
WOVNN2-4S	4	#8	4.3	6.6	7.9	22.2																
WOVNN2-4L	4	#8	4.3	8.5	7.75	23.0																
WOVNN2-5S	5	#10	5.3	9.5	7.5	23.3																
WOVNN2-5L	5	#10	5.3	12.0	11.0	28.0																
WOVNN2-6	6	1/4"	6.5	12.0	11.0	28.0																

尼龙圆形预绝缘端头(TO-JTK型)

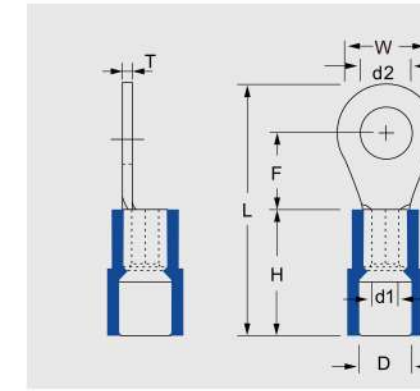

尼龙圆形预绝缘端头

材料: 紫铜

护套: 尼龙

表面处理: 哑光镀锡

颜色:



冷压端子

型号 ITEM NO.	STUD SIZE 螺柱口直径 美制螺柱号		尺寸 DIMENSION mm								包装 PCS/ PACK	颜色 COLOR	使用工具 USE THE TOOLS	说明 EXPLANATION											
	Metric	American	d2	W	F	L	H	d1	D	T															
WOVNN2-8	8	5/16"	8.5	12.0	11.0	28.0	11.0	2.4	4.8	0.8	1000	● 蓝 Blue	HX-30J AN-30J AP-30J FSB-054YJ	端头材质: 紫铜 绝缘材质: PA66 导线截面: 1.5-2.5mm ² 最大电流: I _{max} =27A 最大耐温: 105°C Wire range: 1.5-2.5mm ² A. W. G.: (16-14) Max.current=27A											
WOVNN2-8L	8	5/16"	8.5	13.6	13.9	31.7																			
WOVNN2-10	10	3/8"	10.5	27.0	21.0	45.5																			
WOVNN2-12	12	1/2"	13.0																						
WOVNN2-14	14	9/16"	15.0																						
WOVNN2-16	16	5/8"	17.0																						
WOVNN2-20	20	3/4"	21.0	9.5	8.85	26.6									13.0	3.5	6.7	1.0	500	● 黄 Yellow	HX-30J AN-30J AP-30J FSB-054YJ	端头材质: 紫铜 绝缘材质: PA66 导线截面: 4-6mm ² 最大电流: I _{max} =48A 最大耐温: 105°C Wire range: 4-6mm ² A. W. G.: (12-10) Max.current=48A			
WOVNN5.5-3.2	3.0	#4	3.2																						
WOVNN5.5-3.7	3.5	#6	3.7																				7.2	5.9	22.5
WOVNN5.5-4S	4	#8	4.3																				12.0	10.5	29.5
WOVNN5.5-4L	4	#8	4.3																						
WOVNN5.5-5	5	#10	5.3																				15.0	13.5	34.0
WOVNN5.5-6	6	1/4"	6.5																						
WOVNN5.5-6M	6	1/4"	6.5																						
WOVNN5.5-8	8	5/16"	8.5																						
WOVNN5.5-10	10	3/8"	10.5				32.0	25.2	54.2	16.0	4.8	8.0	1.2	250									● 红 Red	HX-50B CT-80	端头材质: 紫铜 绝缘材质: PA66 导线截面: 6-10mm ² 最大电流: I _{max} =62A 最大耐温: 105°C Wire range: 6-10mm ² A. W. G.: (8) Max.current=62A
WOVNN5.5-12	12	1/2"	13.0																						
WOVNN5.5-14	14	9/16"	15.0																						
WOVNN5.5-16	16	5/8"	17.0																						
WOVNN5.5-20	20	3/4"	21.0																						
WOVNN8-3.7	3.5	#6	3.7	8	9.3	29.3																			
WOVNN8-4S	4.0	#8	4.3	16.0	4.8	8.0	1.2	250	● 红 Red						HX-50B CT-80	端头材质: 紫铜 绝缘材质: PA66 导线截面: 6-10mm ² 最大电流: I _{max} =62A 最大耐温: 105°C Wire range: 6-10mm ² A. W. G.: (8) Max.current=62A									
WOVNN8-5S	5.0	#10	5.3														8.8	9.3	29.7						
WOVNN8-5M	5.0	#10	5.3														12.0	9.3	31.3						
WOVNN8-5L	5.0	#10	5.3														15.0	13.8	37.3						
WOVNN8-6S	6.0	1/4"	6.5														12.0	9.3	31.3						
WOVNN8-6L	6.0	1/4"	6.5														15.0	13.8	37.3						

尼龙圆形预绝缘端头(TO-JTK型)

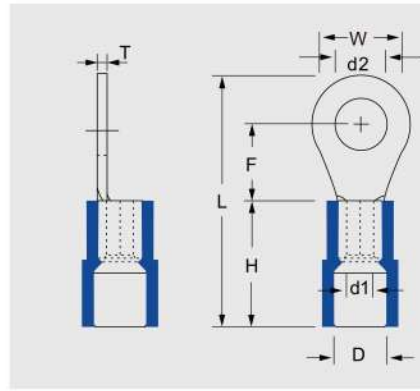

尼龙圆形预绝缘端头

材料: 紫铜

护套: 尼龙

表面处理: 哑光镀锡

颜色:



冷压端子

型号 ITEM NO.	STUD SIZE 螺栓口直径 美制螺栓号		尺寸 DIMENSION mm								包装 PCS/ PACK	颜色 COLOR	使用工具 USE THE TOOLS	说明 EXPLANATION								
	Metric	American	d2	W	F	L	H	d1	D	T												
WOVNN8-8	8	5/16"	8.5	15.0	11.1	37.3	16.0	4.8	8.0	1.2	250	红 Red	HX-50B CT-80	端头材质: 紫铜 绝缘材质: PA66 导线截面: 6-10mm ² 最大电流: I _{max} =62A 最大耐温: 105°C Wire range: 6-10mm ² A. W. G.: (8) Max.current=62A								
WOVNN8-10	10	3/8"	10.5																			
WOVNN8-10L	10	3/8"	10.5																			
WOVNN8-12	12	1/2"	13.0	20.0	15.0	41.0	21.5	6.3	11.0	1.4	250	蓝 Blue	HX-50B CT-80	端头材质: 紫铜 绝缘材质: PA66 导线截面: 10-16mm ² 最大电流: I _{max} =88A 最大耐温: 105°C Wire range: 10-16mm ² A. W. G.: (6) Max.current=88A								
WOVNN14-4	4	#8	4.3																			
WOVNN14-5	5	#10	5.3																			
WOVNN14-6S	6	1/4"	6.5																			
WOVNN14-6L	6	1/4"	6.5																			
WOVNN14-8	8	5/16"	8.5																			
WOVNN14-10	10	3/8"	10.5																			
WOVNN14-10L	10	3/8"	10.5																			
WOVNN14-12	12	1/2"	13.0																			
WOVNN22-5S	5	#10	5.3	12.2	15.1	44.7									23.5	8.1	13.0	1.7	100	黄 Yellow	HX-50B CT-80	端头材质: 紫铜 绝缘材质: PA66 导线截面: 16-25mm ² 最大电流: I _{max} =115A 最大耐温: 105°C Wire range: 16-25mm ² A. W. G.: (4) Max.current=115A
WOVNN22-5L	5	#10	5.3	16.5	13.5	45.2																
WOVNN22-6S	6	1/4"	6.5	12.2	15.1	44.7																
WOVNN22-6L	6	1/4"	6.5	16.5	13.5	45.2																
WOVNN22-8	8	5/16"	8.5																			
WOVNN22-10	10	3/8"	10.5																			
WOVNN22-12	12	1/2"	13.0				22.0	19.5	54.0													
WOVNN38-5	5	#10	5.3	15.3	17.4	52.0	27.0	9.7	14.5	1.7	100	红 Red	HX-50B CT-80	端头材质: 紫铜 绝缘材质: PA66 导线截面: 35mm ² 最大电流: I _{max} =160A 最大耐温: 105°C Wire range: 35mm ² A. W. G.: (2) Max.current=160A								
WOVNN38-6	6	1/4"	6.5																			
WOVNN38-8S	8	5/16"	8.5																			
WOVNN38-8L	8	5/16"	8.5												22.0	17.7	55.7					
WOVNN38-10S	10	3/8"	10.5												15.3	17.4	52.0					
WOVNN38-10L	10	3/8"	10.5												22.0	17.7	55.7					
WOVNN38-12	12	1/2"	13.0																			

尼龙叉形预绝缘端头(TU-JTK型)

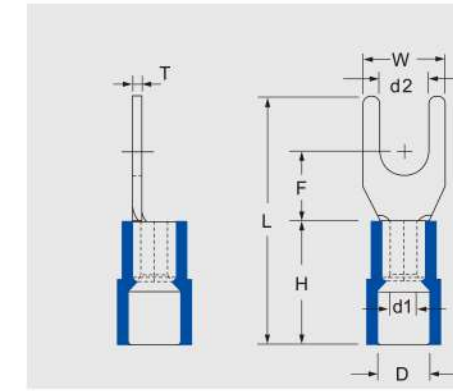

尼龙叉形预绝缘端头

材料: 紫铜

护套: 尼龙

表面处理: 哑光镀锡

颜色:



冷压端子

型号 ITEM NO.	STUD SIZE 螺栓口直径 美制螺栓号		尺寸 DIMENSION mm								包装 PCS/ PACK	颜色 COLOR	使用工具 USE THE TOOLS	说明 EXPLANATION											
	Metric	American	d2	W	F	L	H	d1	D	T															
WYVNN1.25-3.2	3	#4	3.2	5.7	6.5	22.2	11.0	1.8	4.3	0.8	1000	红 Red	HX-30J AN-30J AP-30J FSB-054YJ	端头材质: 紫铜 绝缘材质: PA66 导线截面: 0.5-1.5mm ² 最大电流: I _{max} =19A 最大耐温: 105°C Wire range: 0.5-1.5mm ² A. W. G.: (22-16) Max.current=19A											
WYVNN1.25-3.7S	3.5	#6	3.7																						
WYVNN1.25-3.7L	3.5	#6	3.7												6.4										
WYVNN1.25-3.7LL	3.5	#6	3.7												7.2										
WYVNN1.25-4S	4	#8	4.3	6.4	6.5	22.2	11.0	1.8	4.3	0.8	1000	蓝 Blue	HX-30J AN-30J AP-30J FSB-054YJ	端头材质: 紫铜 绝缘材质: PA66 导线截面: 1.5-2.5mm ² 最大电流: I _{max} =27A 最大耐温: 105°C Wire range: 1.5-2.5mm ² A. W. G.: (16-14) Max.current=27A											
WYVNN1.25-4M	4	#8	4.3	7.2																					
WYVNN1.25-4L	4	#8	4.3	8.1																					
WYVNN1.25-5S	5	#10	5.3	9.5																					
WYVNN1.25-5L	5	#10	5.3																						
WYVNN1.25-6S	6	1/4"	6.5																						
WYVNN1.25-6L	6	1/4"	6.5	12.0											11.0	28.2									
WYVNN1.25-8	8	5/16"	8.5	13.5											11.5	28.0									
WYVNN2-3.2	3	#4	3.2	5.7											6.5	22.2	11.0	2.4	4.8	0.8	1000	蓝 Blue	HX-30J AN-30J AP-30J FSB-054YJ	端头材质: 紫铜 绝缘材质: PA66 导线截面: 1.5-2.5mm ² 最大电流: I _{max} =27A 最大耐温: 105°C Wire range: 1.5-2.5mm ² A. W. G.: (16-14) Max.current=27A	
WYVNN2-3.7S	3.5	#6	3.7																						
WYVNN2-3.7L	3.5	#6	3.7																						6.0
WYVNN2-3.7LL	3.5	#6	3.7																						7.2
WYVNN2-4S	4	#8	4.3		6.4																				
WYVNN2-4M	4	#8	4.3		7.2																				
WYVNN2-4L	4	#8	4.3		8.1																				
WYVNN2-5S	5	#10	5.3		9.5																				
WYVNN2-5L	5	#10	5.3																						
WYVNN2-6L	6	1/4"	6.5			12.0	11.0	28.2																	
WYVNN2-8	8	5/16"	8.5		13.5	11.5	28.0																		

尼龙叉形预绝缘端头(TU-JTK型)

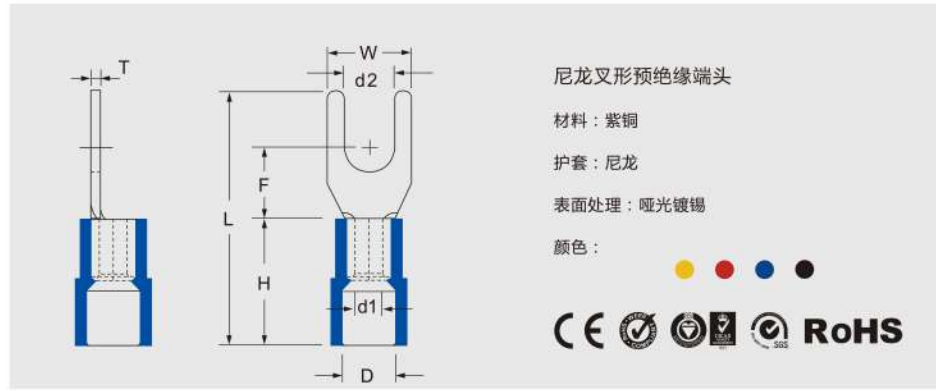

型号 ITEM NO.	STUD SIZE 螺柱口直径 美制螺柱号		尺寸 DIMENSION mm							包装 PCS/ PACK	颜色 COLOR	使用工具 USE THE TOOLS	说明 EXPLANATION		
	Metric	American	d2	W	F	L	H	d1	D					T	
WYVNN5.5-3.7S	3.5	#6	3.7	7.2	7.5	24.4	13.0	3.5	6.7	1.0	500	● 黄 Yellow	HX-30J AN-30J AP-30J FSB-054YJ	端头材质:紫铜 绝缘材质:PA66 导线截面:4-6mm ² 最大电流:I _{max} =48A 最大耐温:105°C Wire range: 4-6mm ² A. W. G. : (12-10) Max.current=48A	
WYVNN5.5-3.7	3.5	#6	3.7	8.3	7.0	25.5									
WYVNN5.5-4SS	4	#8	4.3	7.2	7.5	24.4									
WYVNN5.5-4S	4	#8	4.3	8.3	7.0	25.5									
WYVNN5.5-4L	4	#8	4.3												
WYVNN5.5-5	5	#10	5.3	9.0	7.0	25.5									
WYVNN5.5-6S	6	1/4"	6.5												
WYVNN5.5-6L	6	1/4"	6.5	12.0	12.0	31.7									
WYVNN5.5-8	8	5/16"	8.5	14.0	11.5	30.7	16.0	4.8	8.0	1.2	250	● 红 Red	HX-50B CT-80	端头材质:紫铜 绝缘材质:PA66 导线截面:6-10mm ² 最大电流:I _{max} =62A 最大耐温:105°C Wire range: 6-10mm ² A. W. G. : (8) Max.current=62A	
WYVNN8-4	4	#8	4.3	9.0	7.6	28.3									
WYVNN8-5	5	#10	5.3	9.0	8.1										
WYVNN8-6	6	1/4"	6.5	12.0	9.2	31.3									
WYVNN8-8	8	5/16"	8.5	13.8		10.7	32.9	21.5	6.0	11.0	1.4	250	● 蓝 Blue	HX-50B CT-80	端头材质:紫铜 绝缘材质:PA66 导线截面:10-16mm ² 最大电流:I _{max} =88A 最大耐温:105°C Wire range: 10-16mm ² A. W. G. : (6) Max.current=10-16A
WYVNN14-4	4	#8	4.3	9.0											
WYVNN14-5	5	#10	5.3	9.5	36.5										
WYVNN14-6	6	1/4"	6.5	11.0											
WYVNN14-8	8	5/16"	8.5	13.8		10.7	39.5	23.5	8.1	13.0	1.7	100	● 黄 Yellow	HX-50B CT-80	端头材质:紫铜 绝缘材质:PA66 导线截面:16-25mm ² 最大电流:I _{max} =115A 最大耐温:105°C Wire range: 16-25mm ² A. W. G. : (4) Max.current=16-25A
WYVNN22-5	5	#10	5.3	11.0	9.5	39.3									
WYVNN22-6	6	1/4"	6.5												
WYVNN22-8	8	5/16"	8.5	16.5	13.5	45.0									
WYVNN22-10	10	3/8"	10.5												

尼龙锁扣叉形预绝缘端头

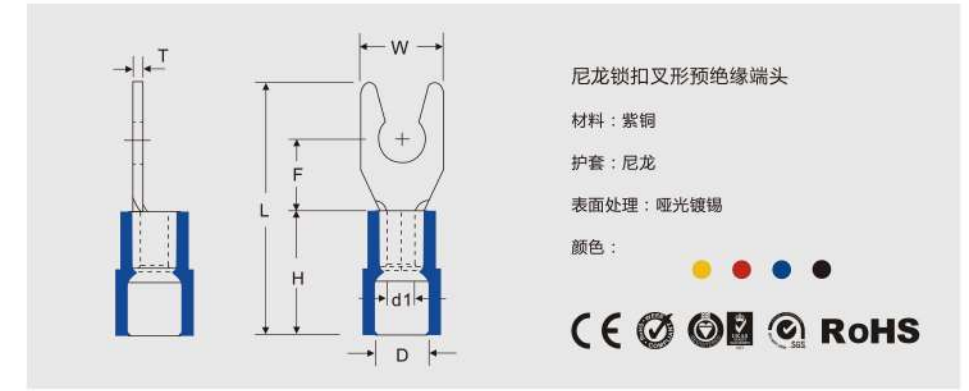

型号 ITEM NO.	STUD SIZE 螺柱口直径 美制螺柱号		尺寸 DIMENSION mm							包装 PCS/ PACK	颜色 COLOR	使用工具 USE THE TOOLS	说明 EXPLANATION	
	Metric	American	d2	W	F	L	H	d1	D					T
WYVSKNN1.25-3.7	3.5	#6	3.7	6.4	6.5	22.2	11.0	1.8	4.3	0.8	1000	● 红 Red	HX-30J AN-30J AP-30J FSB-054YJ	端头材质:紫铜 绝缘材质:PA66 导线截面:0.5-1.5mm ² 最大电流:I _{max} =19A 最大耐温:105°C Wire range: 0.5-1.5mm ² A. W. G. : (22-16) Max.current=19A
WYVSKNN 1.25-4	4	#8	4.3	7.2										
WYVSKNN1.25-5S	5	#10	5.3	8.1										
WYVSKNN 1.25-5L	5	#10	5.3	9.5										
WYVSKNN 2-3.7S	3.5	#6	3.7	6.0	6.5	22.2	11.0	2.4	4.8	0.8	1000	● 蓝 Blue	HX-30J AN-30J AP-30J FSB-054YJ	端头材质:紫铜 绝缘材质:PA66 导线截面:1.5-2.5mm ² 最大电流:I _{max} =27A 最大耐温:105°C Wire range: 1.5-2.5mm ² A. W. G. : (16-14) Max.current=27A
WYVSKNN 2-4	4	#8	4.3	7.2										
WYVSKNN 2-4L	4	#8	4.3	8.1										
WYVSKNN 2-5S	5	#10	5.3	8.1										
WYVSKNN 2-5L	5	#10	5.3	9.5	7.0	25.5	13.0	3.5	6.7	1.0	500	● 黄 Yellow	HX-30J AN-30J AP-30J FSB-054YJ	端头材质:紫铜 绝缘材质:PA66 导线截面:4-6mm ² 最大电流:I _{max} =48A 最大耐温:105°C Wire range: 4-6mm ² A. W. G. : (12-10) Max.current=48A
WYVSKNN 5.5-3.7	3.5	#6	3.7	8.3										
WYVSKNN 5.5-4	4	#8	4.3	8.3										
WYVSKNN 5.5-5	5	#10	5.3	9.0										
WYVSKNN 5.5-6	6	1/4"	6.5	12.0	12.0	31.7								

尼龙凸缘叉形预绝缘端头



尼龙凸缘预绝缘端头
 材料：紫铜
 护套：尼龙
 表面处理：哑光镀锡
 颜色：

CE RoHS

型号 ITEM NO.	STUD SIZE 螺柱口直径 美制螺柱号		尺寸 DIMENSION mm								包装 PCS/ PACK	颜色 COLOR	使用工具 USE THE TOOLS	说明 EXPLANATION
	Metric	American	d2	W	F	L	H	d1	D	T				
WYVTKNN1.25-3.2	3	#4	3.2	7.5	5.1	19.3	11.0	1.8	4.3	0.8	1000	● 红 Red	HX-30J AN-30J AP-30J FSB-054YJ	端头材质:紫铜 绝缘材质:PA66 导线截面:0.5-1.5mm ² 最大电流:I _{max} =19A 最大耐温:105°C Wire range:0.5-1.5mm ² A. W. G.:(22-16) Max.current=19A
WYVTKNN1.25-3.7	3.5	#6	3.7											
WYVTKNN1.25-4	4	#8	4.3											
WYVTKNN1.25-5	5	#10	5.3											
WYVTKNN2-3.7	3.5	#6	3.7	7.5	5.2	21.2	11.0	2.4	4.8	0.8	1000	● 蓝 Blue	HX-30J AN-30J AP-30J FSB-054YJ	端头材质:紫铜 绝缘材质:PA66 导线截面:1.5-2.5mm ² 最大电流:I _{max} =27A 最大耐温:105°C Wire range:1.5-2.5mm ² A. W. G.:(16-14) Max.current=27A
WYVTKNN2-4	4	#8	4.3											
WYVTKNN2-5	5	#10	5.3											
WYVTKNN5.5-3.7	3.5	#6	3.7	8.5	7.5	27.0	13.0	3.5	6.7	1.0	500	● 黄 Yellow	HX-30J AN-30J AP-30J FSB-054YJ	端头材质:紫铜 绝缘材质:PA66 导线截面:4-6mm ² 最大电流:I _{max} =48A 最大耐温:105°C Wire range:4-6mm ² A. W. G.:(12-10) Max.current=48A
WYVTKNN5.5-4	4	#8	4.3											
WYVTKNN5.5-5	5	#10	5.3											

尼龙勾形预绝缘端头(TJ-JTK型)



尼龙勾形预绝缘端头
 材料：紫铜
 护套：尼龙
 表面处理：哑光镀锡
 颜色：

CE RoHS

型号 ITEM NO.	STUD SIZE 螺柱口直径 美制螺柱号		尺寸 DIMENSION mm								包装 PCS/ PACK	颜色 COLOR	使用工具 USE THE TOOLS	说明 EXPLANATION
	Metric	American	d2	W	F	L	H	d1	D	T				
WGXVNN1.25-3.7	3.5	#6	3.7	8.0	7.0	22.0	11.0	1.8	4.3	0.8	1000	● 红 Red	HX-30J AN-30J AP-30J FSB-054YJ	端头材质:紫铜 绝缘材质:PA66 导线截面:0.5-1.5mm ² 最大电流:I _{max} =19A 最大耐温:105°C Wire range:0.5-1.5mm ² A. W. G.:(22-16) Max.current=19A
WGXVNN1.25-4	4	#8	4.3											
WGXVNN1.25-5	5	#10	5.3											
WGXVNN1.25-6	6	1/4"	6.5											
WGXVNN2-3.7	3.5	#6	3.7	8.5	7.75	23.0	11.0	2.4	4.8	0.8	1000	● 蓝 Blue	HX-30J AN-30J AP-30J FSB-054YJ	端头材质:紫铜 绝缘材质:PA66 导线截面:1.5-2.5mm ² 最大电流:I _{max} =27A 最大耐温:105°C Wire range:1.5-2.5mm ² A. W. G.:(16-14) Max.current=27A
WGXVNN2-4	4	#8	4.3											
WGXVNN2-5	5	#10	5.3											
WGXVNN2-6	6	1/4"	6.5	12.0	11.0	28.0	13.0	3.5	6.7	1.0	500	● 黄 Yellow	HX-30J AN-30J AP-30J FSB-054YJ	端头材质:紫铜 绝缘材质:PA66 导线截面:4-6mm ² 最大电流:I _{max} =48A 最大耐温:105°C Wire range:4-6mm ² A. W. G.:(12-10) Max.current=48A
WGXVNN5.5-3.7	3.5	#6	3.7	7.2	5.9	22.7								
WGXVNN5.5-4	4	#8	4.3	9.5	8.85	26.6								
WGXVNN5.5-5	5	#10	5.3											
WGXVNN5.5-6	6	1/4"	6.5	12.0	10.5	29.5	15.0	13.5	34.0					
WGXVNN5.5-8	8	5/16"	8.5											

尼龙片形预绝缘端头

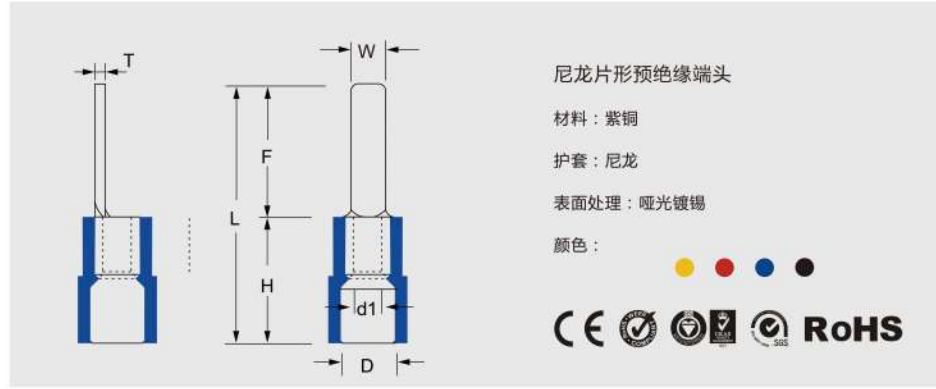
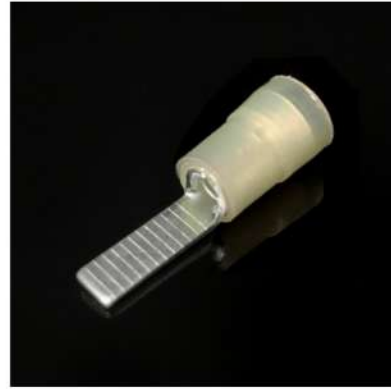

型号 ITEM NO.	尺寸 DIMENSION mm							包装 PCS/ PACK	颜色 COLOR	使用工具 USE THE TOOLS	说明 EXPLANATION
	W	F	L	H	d1	D	T				
WPVNN1.25-9	2.8	9.0	20.0	11.0	1.8	4.3	0.8	1000	● 红 Red	HX-30J AN-30J AP-30J FSB-054YJ	端头材质：紫铜 绝缘材质：PA66 导线截面：0.5-1.5mm ² 最大电流：I _{max} =19A 最大耐温：105°C Wire range：0.5-1.5mm ² A. W. G.：(22-16) Max.current=19A
WPVNN1.25-10	2.3	10.0	21.0								
WPVNN1.25-11	3.0	11.0	22.0								
WPVNN1.25-13	3.0	13.0	24.0								
WPVNN1.25-14	3.0	14.0	25.0								
WPVNN1.25-18	2.2	18.0	29.0								
WPVNN1.25-18S	2.0										
WPVNN2-9	3.0	9.0	20.0	11.0	2.4	4.8	0.8	1000	● 蓝 Blue	HX-30J AN-30J AP-30J FSB-054YJ	端头材质：紫铜 绝缘材质：PA66 导线截面：1.5-2.5mm ² 最大电流：I _{max} =27A 最大耐温：105°C Wire range：1.5-2.5mm ² A. W. G.：(16-14) Max.current=27A
WPVNN2-10	2.4	10.0	21.0								
WPVNN2-13	2.4	13.0	24.0								
WPVNN2-13L	3.0										
WPVNN2-14	2.4	14.0	25.0								
WPVNN2-14L	3.0										
WPVNN2-18S	2.0	18.0	29.0								
WPVNN2-18	2.2										
WPVNN2-18L	2.8										
WPVNN5.5-10	2.8	10.0	23.0	13.0	3.5	6.7	1.0	500	● 黄 Yellow	HX-30J AN-30J AP-30J FSB-054YJ	端头材质：紫铜 绝缘材质：PA66 导线截面：4-6mm ² 最大电流：I _{max} =48A 最大耐温：105°C Wire range：4-6mm ² A. W. G.：(12-10) Max.current=48A
WPVNN5.5-14S	4.0	14.0	27.0								
WPVNN5.5-14	4.5										
WPVNN5.5-18S	2.0	18.0	31.0								
WPVNN5.5-18	4.5										

尼龙凹片形预绝缘端头

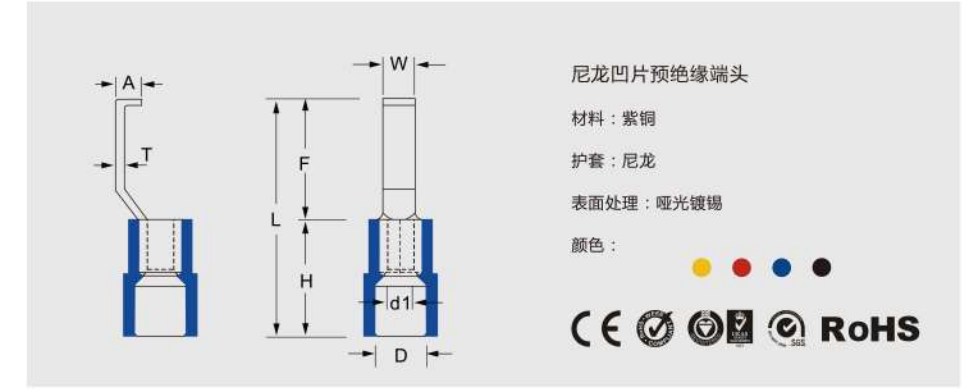

型号 ITEM NO.	尺寸 DIMENSION mm								包装 PCS/ PACK	颜色 COLOR	使用工具 USE THE TOOLS	说明 EXPLANATION
	W	F	L	H	d1	D	T	A				
WPVTYNN1.25-3	3.0	17.8	28.8	11.0	1.8	4.3	0.8	2.1	1000	● 红 Red	HX-30J AN-30J AP-30J FSB-054YJ	端头材质：紫铜 绝缘材质：PA66 导线截面：0.5-1.5mm ² 最大电流：I _{max} =19A 最大耐温：105°C Wire range：0.5-1.5mm ² A. W. G.：(22-16) Max.current=19A
WPVTYNN1.25-4.6												
WPVTYNN2-3	3.0	17.8	28.8	11.0	2.4	4.8	0.8	2.1	1000	● 蓝 Blue	HX-30J AN-30J AP-30J FSB-054YJ	端头材质：紫铜 绝缘材质：PA66 导线截面：1.5-2.5mm ² 最大电流：I _{max} =27A 最大耐温：105°C Wire range：1.5-2.5mm ² A. W. G.：(16-14) Max.current=27A
WPVTYNN2-4.6												
WPVTYNN5.5-3	3.0	18.2	31.2	13.0	3.5	6.7	1.0	2.75	500	● 黄 Yellow	HX-30J AN-30J AP-30J FSB-054YJ	端头材质：紫铜 绝缘材质：PA66 导线截面：4-6mm ² 最大电流：I _{max} =48A 最大耐温：105°C Wire range：4-6mm ² A. W. G.：(12-10) Max.current=48A
WPVTYNN5.5-4.6												

尼龙针形预绝缘端头(TZ-JTK型)



尼龙针形预绝缘端头
 材料：紫铜
 护套：尼龙
 表面处理：哑光镀锡
 颜色：

型号 ITEM NO.	尺寸 DIMENSION mm							包装 PCS/ PACK	颜色 COLOR	使用工具 USE THE TOOLS	说明 EXPLANATION
	W	F	L	H	d1	D	T				
WZVNN1.25-9	1.9	9.0	20.0	11.0	1.8	4.3	0.8	1000	● 红 Red	HX-30J AN-30J AP-30J FSB-054YJ	端头材质:紫铜 绝缘材质:PA66 导线截面:0.5-1.5mm ² 最大电流:Imax=19A 最大耐温:105°C Wire range : 0.5-1.5mm ² A. W. G. : (22-16) Max.current=19A
WZVNN1.25-10		10.0	21.0								
WZVNN1.25-12		12.0	23.0								
WZVNN1.25-13		13.0	24.0								
WZVNN1.25-14		14.0	25.0								
WZVNN1.25-17		17.0	28.0								
WZVNN2-9	1.9	9.0	20.0	11.0	2.4	4.8	0.8	1000	● 蓝 Blue	HX-30J AN-30J AP-30J FSB-054YJ	端头材质:紫铜 绝缘材质:PA66 导线截面:1.5-2.5mm ² 最大电流:Imax=27A 最大耐温:105°C Wire range : 1.5-2.5mm ² A. W. G. : (16-14) Max.current=27A
WZVNN2-10		10.0	21.0								
WZVNN2-12		12.0	23.0								
WZVNN2-13		13.0	24.0								
WZVNN2-17		17.0	28.0								
WZVNN5.5-13		2.8	13.0								
WZVNN5.5-25	25		38								

圆形裸端头(TO型)



圆形裸端头
 材料：紫铜
 表面处理：哑光镀锡

型号 ITEM NO.	STUD SIZE 螺栓口直径 美制螺栓号		尺寸 DIMENSION mm								包装 PCS/ PACK	使用工具 USE THE TOOLS	说明 EXPLANATION	
	Metric	American	d2	W	F	L	H	d1	D	T				
WON 0.5-2.2	2	#2	2.2	5.0	6.0	12.5	4.0	1.2	2.2	0.5	1000	SN-02	端头材质:紫铜 导线截面:0.2-0.5mm ² 最大电流:Imax=9A Wire range : 0.2-0.5mm ² A. W. G. : (26-22) Max.current=9A	
WON 0.5-2.7	2.5	#3	2.7											
WON 0.5-3.2	3	#4	3.2											
WON 0.5-4	4	#8	4.3	6.5	8.5	15.25	4.8	1.8	3.4	0.8	1000	HX-10 AN-10 AP-10 FSB-056TD	端头材质:紫铜 导线截面:0.5-1.5mm ² 最大电流:Imax=19A Wire range : 0.5-1.5mm ² A. W. G. : (22-16) Max.current=19A	
WON 0.5-5	5	#10	5.3	8.0	8.0	16.0								
WON 1.25-3.2	3	#4	3.2	5.7	4.95	12.6								
WON 1.25-3.7S	3.5	#6	3.7	6.6	6.3	14.4								
WON 1.25-3.7M	3.5	#6	3.7	8.0	7.0	15.8								
WON 1.25-3.7L	3.5	#6	3.7	8.0	7.0	15.8								
WON 1.25-4S	4	#8	4.3	6.6	6.3	14.4								
WON 1.25-4L	4	#8	4.3	8.0	7.0	15.8								
WON 1.25-5	5	#10	5.3	9.5	7.5	17.1								
WON 1.25-5L	5	#10	5.3	11.6	11.2	21.8								
WON 1.25-6	6	1/4 "	6.5	13.6	13.9	25.5								
WON 1.25-8	8	5/16 "	8.5											
WON 1.25-8L	8	5/16 "	8.5											
WON 1.25-10	10	3/8 "	10.5											
WON 1.25-12	12	1/2 "	13.0	19.2	16.0	30.4	27.0	21.0	39.3	4.8	1.8	3.4	0.8	500
WON 1.25-14	14	9/16 "	15.0											
WON 1.25-16	16	5/8 "	17.0											
WON 1.25-20	20	3/4 "	21.0											
WON 2-3.2S	3	#4	3.2	5.5	4.8	12.4	4.8	2.4	4.0	0.8	1000	HX-10 AN-10 AP-10 FSB-056TD	端头材质:紫铜 导线截面:1.5-2.5mm ² 最大电流:Imax=27A Wire range : 1.5-2.5mm ² A. W. G. : (16-14) Max.current=27A	
WON 2-3.2	3	#4	3.2	6.6	6.4	14.5								
WON 2-3.7	3.5	#6	3.7	6.6	7.9	16.0								
WON 2-3.7M	3.5	#6	3.7	8.5	7.75	16.8								
WON 2-3.7L	3.5	#6	3.7	8.5	7.75	16.8	12.0	11.0	21.8	4.8	2.4	4.0	0.8	1000
WON 2-4S	4	#8	4.3	6.6	7.9	16.0								
WON 2-4L	4	#8	4.3	8.5	7.75	16.8								
WON 2-5S	5	#10	5.3	9.5	7.5	17.1								
WON 2-5L	5	#10	5.3	12.0	11.0	21.8	13.6	13.9	25.5	4.8	2.4	4.0	0.8	1000
WON 2-6	6	1/4 "	6.5											
WON 2-8	8	5/16 "	8.5											
WON 2-8L	8	5/16 "	8.5											
WON 2-10	10	3/8 "	10.5	19.2	16.0	30.4	27.0	21.0	39.3	4.8	2.4	4.0	0.8	500
WON 2-12	12	1/2 "	13.0											
WON 2-14	14	9/16 "	15.0											
WON 2-16	16	5/8 "	17.0											
WON 2 20	20	3/4 "	21.0											

冷压端子

冷压端子

圆形裸端头(TO型)

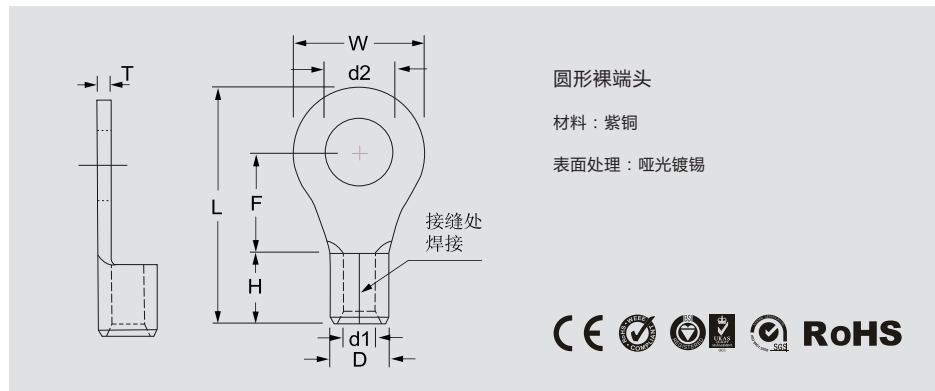

型号 ITEM NO.	STUD SIZE 螺栓口直径 美制螺栓号		尺寸 DIMENSION mm								包装 PCS/ PACK	使用工具 USE THE TOOLS	说明 EXPLANATION	
	Metric	American	d2	W	F	L	H	d1	D	T				
WON 3.5-4	4	#8	4.3	8.0	7.7	17.7	6.0	3.0	5.0	1.0	1000	HX-10 AN-10 AP-10 FSB-056TD	端头材质:紫铜 导线截面:2.5-4mm ² 最大电流:I _{max} =37A Wire range : 2.5-4mm ² A. W. G. : (14-12) Max.current=37A	
WON 3.5-5S	5	#10	5.3											
WON 3.5-5L	5	#10	5.3	12.0	9.4	21.4	6.0	3.0	5.0	1.0	1000	HX-10 AN-10 AP-10 FSB-056TD	端头材质:紫铜 导线截面:2.5-4mm ² 最大电流:I _{max} =37A Wire range : 2.5-4mm ² A. W. G. : (14-12) Max.current=37A	
WON 3.5-6	6	1/4 "	6.5											
WON 3.5-8	8	5/16 "	8.5	15.0	13.5	27.0	6.0	3.0	5.0	1.0	1000	HX-10 AN-10 AP-10 FSB-056TD	端头材质:紫铜 导线截面:2.5-4mm ² 最大电流:I _{max} =37A Wire range : 2.5-4mm ² A. W. G. : (14-12) Max.current=37A	
WON 3.5-10	10	3/8 "	10.5											
WON 3.5-12	12	1/2 "	13.0	19.2	16.0	31.6	6.0	3.0	5.0	1.0	1000	HX-10 AN-10 AP-10 FSB-056TD	端头材质:紫铜 导线截面:2.5-4mm ² 最大电流:I _{max} =37A Wire range : 2.5-4mm ² A. W. G. : (14-12) Max.current=37A	
WON 5.5-3.2	3	#4	3.2	7.2	5.9	16.3	6.8	6.0	3.5	5.5	1.0	1000	HX-10 AN-10 AP-10 FSB-056TD	端头材质:紫铜 导线截面:4-6mm ² 最大电流:I _{max} =48A Wire range : 4-6mm ² A. W. G. : (12-10) Max.current=48A
WON 5.5-3.7	3.5	#6	3.7											
WON 5.5-4S	4	#8	4.3	12.0	10.5	22.5	6.0	3.5	5.5	1.0	1000	HX-10 AN-10 AP-10 FSB-056TD	端头材质:紫铜 导线截面:4-6mm ² 最大电流:I _{max} =48A Wire range : 4-6mm ² A. W. G. : (12-10) Max.current=48A	
WON 5.5-4L	4	#8	4.3											
WON 5.5-5	5	#10	5.3	15.0	13.5	27.0	6.0	3.5	5.5	1.0	500	HX-10 AN-10 AP-10 FSB-056TD	端头材质:紫铜 导线截面:4-6mm ² 最大电流:I _{max} =48A Wire range : 4-6mm ² A. W. G. : (12-10) Max.current=48A	
WON 5.5-6	6	1/4 "	6.5											
WON 5.5-6M	6	1/4 "	6.5	32.0	25.2	47.2	6.0	3.5	5.5	1.0	250	HX-10 AN-10 AP-10 FSB-056TD	端头材质:紫铜 导线截面:4-6mm ² 最大电流:I _{max} =48A Wire range : 4-6mm ² A. W. G. : (12-10) Max.current=48A	
WON 5.5-8	8	5/16 "	8.5											
WON 5.5-10	10	3/8 "	10.5	19.2	16.0	31.6	6.0	3.5	5.5	1.0	500	HX-10 AN-10 AP-10 FSB-056TD	端头材质:紫铜 导线截面:4-6mm ² 最大电流:I _{max} =48A Wire range : 4-6mm ² A. W. G. : (12-10) Max.current=48A	
WON 5.5-12	12	1/2 "	13.0											
WON 5.5-14	14	9/16 "	15.0	32.0	25.2	47.2	6.0	3.5	5.5	1.0	250	HX-10 AN-10 AP-10 FSB-056TD	端头材质:紫铜 导线截面:4-6mm ² 最大电流:I _{max} =48A Wire range : 4-6mm ² A. W. G. : (12-10) Max.current=48A	
WON 5.5-16	16	5/8 "	17.0											
WON 5.5-20	20	3/4 "	21.0	8.0	9.3	21.8	8.5	4.8	7.2	1.2	1000	HX-10 AN-10 AP-10 FSB-056TD	端头材质:紫铜 导线截面:4-6mm ² 最大电流:I _{max} =48A Wire range : 4-6mm ² A. W. G. : (12-10) Max.current=48A	
WON 8-3.7	3.5	#6	3.7											
WON 8-4S	4	#8	4.3	12.0	9.3	23.8	8.5	4.8	7.2	1.2	1000	HX-50B CT-80 FSB-616TD	端头材质:紫铜 导线截面:6-10mm ² 最大电流:I _{max} =62A Wire range : 6-10mm ² A. W. G. : (8) Max.current=62A	
WON 8-4L	4	#8	4.3											
WON 8-5S	5	#10	5.3	15.0	13.8	29.8	8.5	4.8	7.2	1.2	500	HX-50B CT-80 FSB-616TD	端头材质:紫铜 导线截面:6-10mm ² 最大电流:I _{max} =62A Wire range : 6-10mm ² A. W. G. : (8) Max.current=62A	
WON 8-5M	5	#10	5.3											
WON 8-5L	5	#10	5.3	20.0	15.0	33.5	8.5	4.8	7.2	1.2	500	HX-50B CT-80 FSB-616TD	端头材质:紫铜 导线截面:6-10mm ² 最大电流:I _{max} =62A Wire range : 6-10mm ² A. W. G. : (8) Max.current=62A	
WON 8-6S	6	1/4 "	6.5											
WON 8-6L	6	1/4 "	6.5	15.0	13.8	29.8	8.5	4.8	7.2	1.2	1000	HX-50B CT-80 FSB-616TD	端头材质:紫铜 导线截面:6-10mm ² 最大电流:I _{max} =62A Wire range : 6-10mm ² A. W. G. : (8) Max.current=62A	
WON 8-8	8	5/16 "	8.5											
WON 8-10	10	3/8 "	10.5	20.0	15.0	33.5	8.5	4.8	7.2	1.2	500	HX-50B CT-80 FSB-616TD	端头材质:紫铜 导线截面:6-10mm ² 最大电流:I _{max} =62A Wire range : 6-10mm ² A. W. G. : (8) Max.current=62A	
WON 8-10L	10	3/8 "	10.5											
WON 8-12	12	1/2 "	13.0	15.0	13.8	29.8	8.5	4.8	7.2	1.2	1000	HX-50B CT-80 FSB-616TD	端头材质:紫铜 导线截面:6-10mm ² 最大电流:I _{max} =62A Wire range : 6-10mm ² A. W. G. : (8) Max.current=62A	
WON 8-8	8	5/16 "	8.5											

圆形裸端头(TO型)

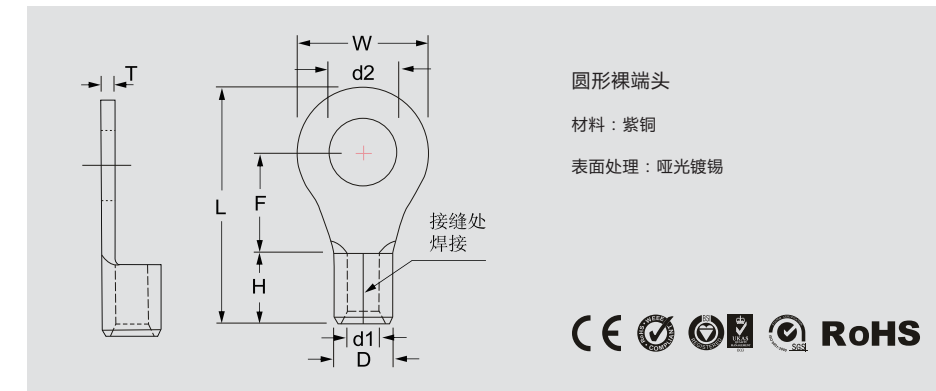

型号 ITEM NO.	STUD SIZE 螺栓口直径 美制螺栓号		尺寸 DIMENSION mm								包装 PCS/ PACK	使用工具 USE THE TOOLS	说明 EXPLANATION
	Metric	American	d2	W	F	L	H	d1	D	T			
WON14-4	4	#8	4.3	12.0	13.3	29.8	10.5	6.3	9.3	1.4	500	HX-50B CT-80 FSC-616TD	端头材质:紫铜 导线截面:10-16mm ² 最大电流:I _{max} =88A Wire range : 10-16mm ² A. W. G. : (6) Max.current=88A
WON14-5	5	#10	5.3										
WON14-6S	6	1/4 "	6.5	16.0	14.0	32.5	10.5	6.3	9.3	1.4	500	HX-50B CT-80 FSC-616TD	端头材质:紫铜 导线截面:10-16mm ² 最大电流:I _{max} =88A Wire range : 10-16mm ² A. W. G. : (6) Max.current=88A
WON14-6L	6	1/4 "	6.5										
WON14-8	8	5/16 "	8.5	22.0	19.5	41.0	10.5	6.0	9.0	1.4	250	HX-50B CT-80 FSC-616TD	端头材质:紫铜 导线截面:10-16mm ² 最大电流:I _{max} =88A Wire range : 10-16mm ² A. W. G. : (6) Max.current=88A
WON14-10	10	3/8 "	10.5										
WON14-10L	10	3/8 "	10.5	28.0	24.0	48.5	10.5	6.0	9.0	1.4	250	HX-50B CT-80 FSC-616TD	端头材质:紫铜 导线截面:10-16mm ² 最大电流:I _{max} =88A Wire range : 10-16mm ² A. W. G. : (6) Max.current=88A
WON14-12	12	1/2 "	13.0										
WON14-14	14	9/16 "	15.0	28.0	24.0	48.5	10.5	6.0	9.0	1.4	250	HX-50B CT-80 FSC-616TD	端头材质:紫铜 导线截面:10-16mm ² 最大电流:I _{max} =88A Wire range : 10-16mm ² A. W. G. : (6) Max.current=88A
WON14-16	16	5/8 "	17.0										
WON14-20	20	3/4 "	21.0	12.2	15.1	33.2	12.0	8.1	11.5	1.7	250	HX-50B CT-80 FSC-616TD	端头材质:紫铜 导线截面:16-25mm ² 最大电流:I _{max} =115A Wire range : 16-25mm ² A. W. G. : (4) Max.current=115A
WON22-4	4	#8	4.3										
WON22-5S	5	#10	5.3	16.5	13.5	33.7	12.0	8.1	11.5	1.7	250	HX-50B CT-80 FSC-616TD	端头材质:紫铜 导线截面:16-25mm ² 最大电流:I _{max} =115A Wire range : 16-25mm ² A. W. G. : (4) Max.current=115A
WON22-5L	5	#10	5.3										
WON22-6S	6	1/4 "	6.5	16.5	13.5	33.7	12.0	8.1	11.5	1.7	250	HX-50B CT-80 FSC-616TD	端头材质:紫铜 导线截面:16-25mm ² 最大电流:I _{max} =115A Wire range : 16-25mm ² A. W. G. : (4) Max.current=115A
WON22-6L	6	1/4 "	6.5										
WON22-8	8	5/16 "	8.5	22.0	19.5	42.5	12.0	8.1	11.5	1.7	200	HX-50B CT-80 FSC-616TD	端头材质:紫铜 导线截面:16-25mm ² 最大电流:I _{max} =115A Wire range : 16-25mm ² A. W. G. : (4) Max.current=115A
WON22-10	10	3/8 "	10.5										
WON22-10L	10	3/8 "	10.5	28.0	24.0	50.0	12.0	8.1	11.5	1.7	200	HX-50B CT-80 FSC-616TD	端头材质:紫铜 导线截面:16-25mm ² 最大电流:I _{max} =115A Wire range : 16-25mm ² A. W. G. : (4) Max.current=115A
WON22-12	12	1/2 "	13.0										
WON22-14	14	9/16 "	15.0	15.3	17.4	39.0	14.0	9.7	13.3	1.7	200	HX-50B CT-80 FSC-616TD	端头材质:紫铜 导线截面:16-25mm ² 最大电流:I _{max} =115A Wire range : 16-25mm ² A. W. G. : (4) Max.current=115A
WON22-16	16	5/8 "	17.0										
WON22-20	20	3/4 "	21.0	22.0	17.7	42.7	14.0	9.7	13.3	1.7	100	HX-50B CT-80 FSC-616TD	端头材质:紫铜 导线截面:16-25mm ² 最大电流:I _{max} =115A Wire range : 16-25mm ² A. W. G. : (4) Max.current=115A
WON38-5	5	#10	5.3										
WON38-6S	6	1/4 "	6.5	15.3	17.4	39.0	14.0	9.7	13.3	1.7	200	HX-50B CT-80 FSC-616TD	端头材质:紫铜 导线截面:16-25mm ² 最大电流:I _{max} =115A Wire range : 16-25mm ² A. W. G. : (4) Max.current=115A
WON38-6L	6	1/4 "	6.5										
WON38-8S	8	5/16 "	8.5	22.0	17.7	42.7	14.0	9.7	13.3	1.7	100	HX-50B CT-80 FSC-616TD	端头材质:紫铜 导线截面:16-25mm ² 最大电流:I _{max} =115A Wire range : 16-25mm ² A. W. G. : (4) Max.current=115A
WON38-8L	8	5/16 "	8.5										
WON38-10S	10	3/8 "	10.5	28.0	24.0	52.0	14.0	9.7	13.3	1.7	100	HX-50B CT-80 FSC-616TD	端头材质:紫铜 导线截面:16-25mm ² 最大电流:I _{max} =115A Wire range : 16-25mm ² A. W. G. : (4) Max.current=115A
WON38-10L	10	3/8 "	10.5										
WON38-12	12	1/2 "	13.0	15.3	17.4	39.0	14.0	9.7	13.3	1.7	200	HX-50B CT-80 FSC-616TD	端头材质:紫铜 导线截面:16-25mm ² 最大电流:I _{max} =115A Wire range : 16-25mm ² A. W. G. : (4) Max.current=115A
WON38-14	14	9/16 "	15.0										
WON38-16	16	5/8 "	17.0	22.0	17.7	42.7	14.0	9.7	13.3	1.7	100	HX-50B CT-80 FSC-616TD	端头材质:紫铜 导线截面:16-25mm ² 最大电流:I _{max} =115A Wire range : 16-25mm ² A. W. G. : (4) Max.current=115A
WON38-20	20	3/4 "	21.0										

圆形裸端头(TO型)

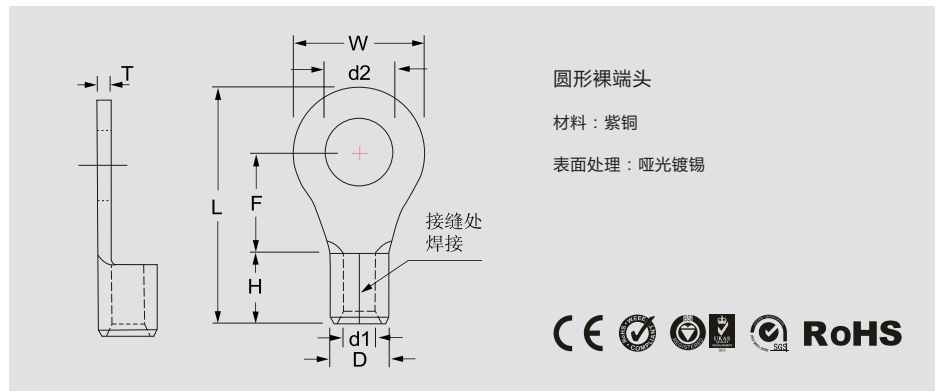

型号 ITEM NO.	STUD SIZE 螺栓口直径 美制螺栓号		尺寸 DIMENSION mm								包装 PCS/ PACK	使用工具 USE THE TOOLS	说明 EXPLANATION
	Metric	American	d2	W	F	L	H	d1	D	T			
WON60-6S	6	1/4"	6.5	16.0	17.7	43.7	18.0	11.8	15.4	1.8	100	CT-80 端头材质:紫铜 导线截面:50mm ² 最大电流:Imax=215A Wire range : 50mm ² A. W. G. : (1/0) Max.current=215A	
WON60-8S	8	5/16"	8.5										
WON60-10S	10	3/8"	10.5										
WON60-12S	12	1/2"	13.0	19.0	17.7	45.2	22.0	20.7	49.7	50			
WON60-5	5	#10	5.3										
WON60-6	6	1/4"	6.5										
WON60-8	8	5/16"	8.5	32.0	23.5	57.5	18.0	11.8	15.4	1.8	50		
WON60-10	10	3/8"	10.5										
WON60-12	12	1/2"	13.0										
WON60-14	14	9/16"	15.0	17.5	20.0	47.0	18.0	13.5	17.5	1.9	50		
WON60-16	16	5/8"	17.0										
WON60-18	18	11/16"	19.0										
WON60-20	20	3/4"	21.0	24.0	20.0	50.0	24.0	20.0	50.0	50			
WON60-22	22	7/8"	23.0										
WON70-6S	6	1/4"	6.5										
WON70-8S	8	5/16"	8.5	32.0	27.0	61.0	18.0	13.5	17.5	1.9	50		
WON70-10S	10	3/8"	10.5										
WON70-12S	12	1/2"	13.0										
WON70-6	6	1/4"	6.5	27.0	20.7	53.2	19.0	15.1	19.5	2.2	50		
WON70-8	8	5/16"	8.5										
WON70-10	10	3/8"	10.5										
WON70-12	12	1/2"	13.0	32.0	32.0	67.0	19.0	15.1	19.5	2.2	50		
WON70-14	14	9/16"	15.0										
WON70-16	16	5/8"	17.0										
WON70-18	18	11/16"	19.0	27.0	20.7	53.2	19.0	15.1	19.5	2.2	50		
WON70-20	20	3/4"	21.0										
WON70-22	22	7/8"	23.0										
WON80-6	6	1/4"	6.5	32.0	32.0	67.0	19.0	15.1	19.5	2.2	50		
WON80-8	8	5/16"	8.5										
WON80-10	10	3/8"	10.5										
WON80-12	12	1/2"	13.0	36.0	23.0	68.0	27.0	20.2	26.6	3.2	25		
WON80-14	14	9/16"	15.0										
WON80-16	16	5/8"	17.0										
WON80-18	18	11/16"	19.0	36.0	36.0	81.0	27.0	20.2	26.6	3.2	25		
WON80-20	20	3/4"	21.0										
WON80-22	22	7/8"	23.0										
WON80-6	6	1/4"	6.5	36.0	23.0	68.0	27.0	20.2	26.6	3.2	25		
WON80-8	8	5/16"	8.5										
WON80-10	10	3/8"	10.5										
WON80-12	12	1/2"	13.0	36.0	36.0	81.0	27.0	20.2	26.6	3.2	25		
WON80-14	14	9/16"	15.0										
WON80-16	16	5/8"	17.0										
WON80-18	18	11/16"	19.0	36.0	36.0	81.0	27.0	20.2	26.6	3.2	25		
WON80-20	20	3/4"	21.0										
WON80-22	22	7/8"	23.0										

圆形裸端头(TO型)

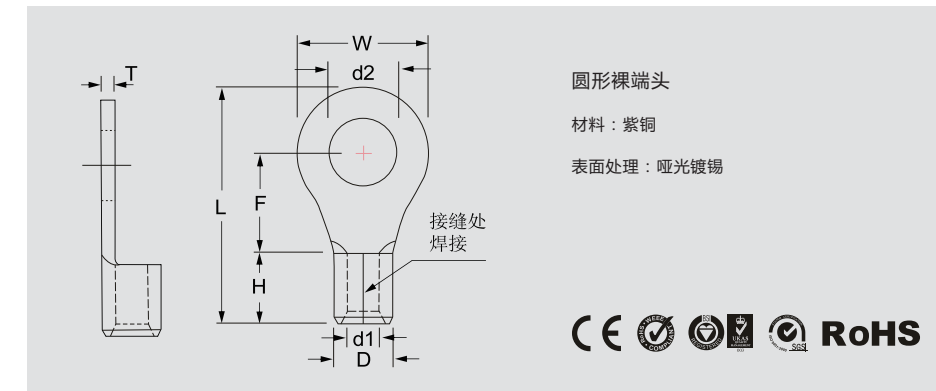

型号 ITEM NO.	STUD SIZE 螺栓口直径 美制螺栓号		尺寸 DIMENSION mm								包装 PCS/ PACK	使用工具 USE THE TOOLS	说明 EXPLANATION
	Metric	American	d2	W	F	L	H	d1	D	T			
WON100-6	6	1/4"	6.5	28.5	20.4	55.6	21.0	17.1	22.1	2.5	25	CT-150 端头材质:紫铜 导线截面:120mm ² 最大电流:Imax=300A Wire range : 120mm ² A. W. G. : (4/0) Max.current=300A	
WON100-8	8	5/16"	8.5										
WON100-10	10	3/8"	10.5										
WON100-12	12	1/2"	13.0	32.0	32.0	69.0	24.0	18.0	24.0	3.0	25		
WON100-14	14	9/16"	15.0										
WON100-16	16	5/8"	17.0										
WON100-18	18	11/16"	19.0	32.0	22.0	62.0	32.0	32.0	72.0	50			
WON100-20	20	3/4"	21.0										
WON100-22	22	7/8"	23.0										
WON125-8	8	5/16"	8.5	32.0	22.0	62.0	32.0	32.0	72.0	50			
WON125-10	10	3/8"	10.5										
WON125-12	12	1/2"	13.0										
WON125-14	14	9/16"	15.0	36.0	23.0	68.0	27.0	20.2	26.6	3.2	25		
WON125-16	16	5/8"	17.0										
WON125-20	20	3/4"	21.0										
WON125-22	22	7/8"	23.0	36.0	36.0	81.0	27.0	20.2	26.6	3.2	25		
WON150-8	8	5/16"	8.5										
WON150-10	10	3/8"	10.5										
WON150-12	12	1/2"	13.0	36.0	36.0	81.0	27.0	20.2	26.6	3.2	25		
WON150-14	14	9/16"	15.0										
WON150-16	16	5/8"	17.0										
WON150-18	18	11/16"	19.0	36.0	36.0	81.0	27.0	20.2	26.6	3.2	25		
WON150-20	20	3/4"	21.0										
WON150-22	22	7/8"	23.0										
WON150-24	24	15/16"	25.0	36.0	36.0	81.0	27.0	20.2	26.6	3.2	25		
WON150-27	27	1"	28.0										

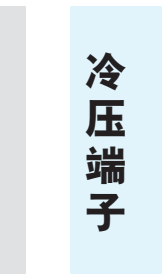

圆形裸端头(TO型)

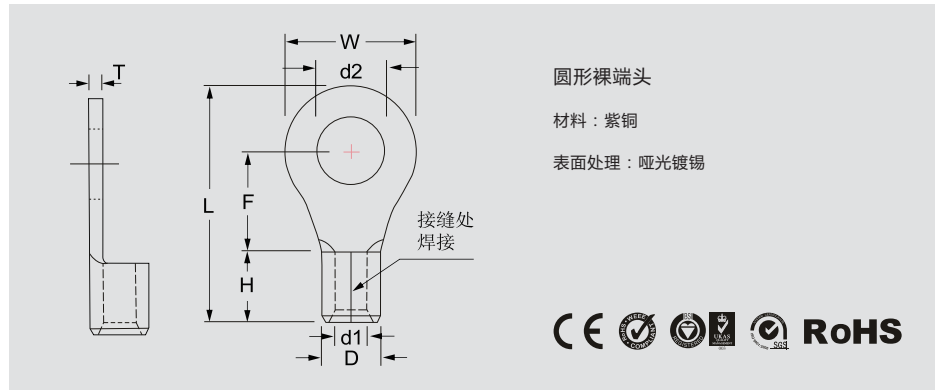

型号 ITEM NO.	STUD SIZE 螺栓口直径 美制螺栓号		尺寸 DIMENSION mm								包装 PCS/ PACK	使用工具 USE THE TOOLS	说明 EXPLANATION
	Metric	American	d2	W	F	L	H	d1	D	T			
WON180-8	8	5/16"	8.5	38.5	24.5	72.3	28.5	21.6	28.6	3.5	20	HX245B	端头材质: 紫铜 导线截面: 185mm ² 最大电流: I _{max} =440A Wire range: 185mm ² A. W. G.: (300/350MCM) Max.current=440A
WON180-10	10	3/8"	10.5										
WON180-12	12	1/2"	13.0										
WON180-14	14	9/16"	15.0										
WON180-16	16	5/8"	17.0	38.5	39.0	86.7	28.5	21.6	28.6	3.5	20	HX245B	
WON180-18	18	11/16"	19.0										
WON180-20	20	3/4"	21.0										
WON180-22	22	7/8"	23.0										
WON180-24	24	15/16"	25.0	44.0	24.5	78.0	31.5	24.8	32.6	3.9	10	HX245B	
WON180-27	27	1	28.0										
WON200-8	8	5/16"	8.5										
WON200-10	10	3/8"	10.5										
WON200-12	12	1/2"	13.0	44.0	37.5	91.0	31.5	24.8	32.6	3.9	10	HX245B	
WON200-14	14	9/16"	15.0										
WON200-16	16	5/8"	17.0										
WON200-18	18	11/16"	19.0										
WON200-20	20	3/4"	21.0	50.5	33.5	94.3	35.5	28.7	37.1	4.2	5	端头材质: 紫铜 导线截面: 240mm ² 最大电流: I _{max} =470A Wire range: 240mm ² A. W. G.: (400/500MCM) Max.current=470A	
WON200-22	22	7/8"	23.0										
WON200-24	24	15/16"	25.0										
WON200-27	27	1	28.0										
WON325-8	8	5/16"	8.5	50.5	45.0	105.7	35.5	28.7	37.1	4.2	5		HX245B
WON325-10	10	3/8"	10.5										
WON325-12	12	1/2"	13.0										
WON325-14	14	9/16"	15.0										
WON325-16	16	5/8"	17.0	50.5	45.0	105.7	35.5	28.7	37.1	4.2	5		HX245B
WON325-18	18	11/16"	19.0										
WON325-20	20	3/4"	21.0										
WON325-22	22	7/8"	23.0										
WON325-24	24	15/16"	25.0	50.5	45.0	105.7	35.5	28.7	37.1	4.2	5	HX245B	
WON325-27	27	1	28.0										

方形裸端头

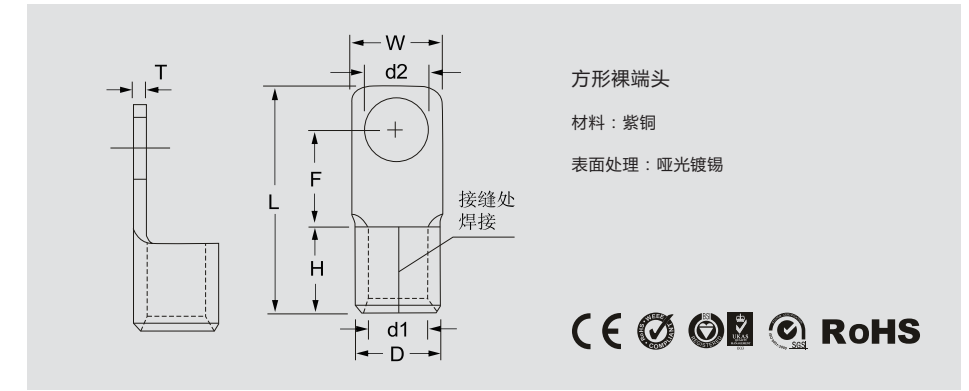

型号 ITEM NO.	STUD SIZE 螺栓口直径 美制螺栓号		尺寸 DIMENSION mm								包装 PCS/ PACK	使用工具 USE THE TOOLS	说明 EXPLANATION
	Metric	American	d2	W	F	L	H	d1	D	T			
WFON22-5	5	#10	5.3	12.5	13.5	32.0	12.0	8.1	11.5	1.7	250	HX-50B CT-80	端头材质: 紫铜 导线截面: 16-25mm ² A. W. G.: (4) 最大电流: I _{max} =115A
WFON22-6	6	1/4"	6.5										
WFON22-8	8	5/16"	8.5										
WFON38-5	5	#10	5.3	13.5	16.3	38.0	14.0	9.7	13.3	1.7	200	HX-50B CT-80	端头材质: 紫铜 导线截面: 35mm ² A. W. G.: (2) 最大电流: I _{max} =160A
WFON38-6	6	1/4"	6.5										
WFON38-8	8	5/16"	8.5										
WFON38-10	10	3/8"	10.5	16.0	20.7	47.2	18.0	11.8	15.4	1.8	100	HX-50B CT-80	端头材质: 紫铜 导线截面: 50mm ² A. W. G.: (1/0) 最大电流: I _{max} =215A
WFON60-6	6	1/4"	6.5										
WFON60-8	8	5/16"	8.5										
WFON60-10	10	3/8"	10.5	17.5	20.0	48.0	18.0	13.5	17.5	1.9	50	CT-80 CT-150	端头材质: 紫铜 导线截面: 70mm ² A. W. G.: (2/0) 最大电流: I _{max} =235A
WFON70-8	8	5/16"	8.5										
WFON70-10	10	3/8"	10.5										
WFON70-12	12	1/2"	13	21.8	20.0	49.0	19.0	15.1	19.5	2.2	50	CT-80 CT-150	端头材质: 紫铜 导线截面: 95mm ² A. W. G.: (3/0) 最大电流: I _{max} =255A
WFON80-8	8	5/16"	8.5										
WFON80-10	10	3/8"	10.5										
WFON80-12	12	1/2"	13.0	21.8	21.0	54.0	21.0	17.1	22.1	2.5	25	CT-150	端头材质: 紫铜 导线截面: 120mm ² A. W. G.: (4/0) 最大电流: I _{max} =300A
WFON100-8	8	5/16"	8.5										
WFON100-10	10	3/8"	10.5										
WFON100-12	12	1/2"	13.0	22.0	22.3	61.3	27.0	20.2	26.6	3.2	25	CT-150	端头材质: 紫铜 导线截面: 150mm ² A. W. G.: (250/300MCM) 最大电流: I _{max} =395A
WFON150-8	8	5/16"	8.5										
WFON150-10	10	3/8"	10.5										
WFON150-12	12	1/2"	13.0	36.0	22.3	73.0	31.5	24.8	32.6	3.9	10	CT-180	端头材质: 紫铜 导线截面: 240mm ² A. W. G.: (400/500MCM) 最大电流: I _{max} =470A
WFON200-10	10	3/8"	10.5										
WFON200-12	12	1/2"	13.0										

叉形裸端头(TU型)

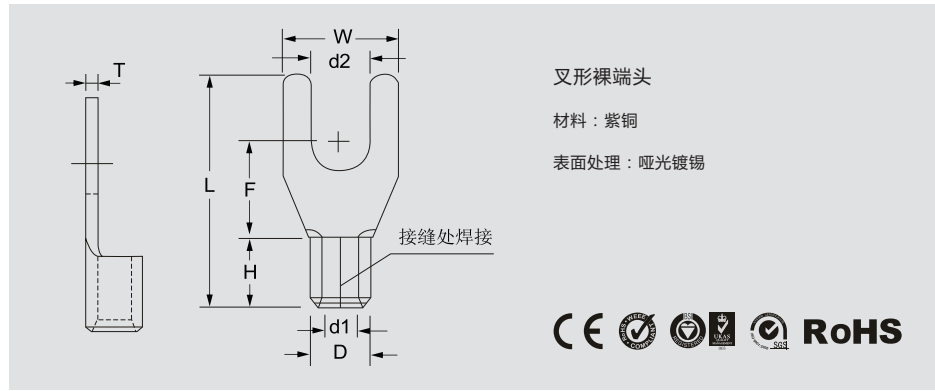

型号 ITEM NO.	STUD SIZE 螺栓口直径 美制螺栓号		尺寸 DIMENSION mm								包装 PCS/ PACK	使用工具 USE THE TOOLS	说明 EXPLANATION
	Metric	American	d2	W	F	L	H	d1	D	T			
WYN0.5-2	2	#2	2.2	5	4.5	12.5	4.0	1.2	2.2	0.5	1000	SN-02	端头材质:紫铜 导线截面:0.2-0.5mm ² 最大电流:I _{max} =9A Wire range : 0.2-0.5mm ² A. W. G. : (26-22) Max.current=9A
WYN0.5-3.2	3	#4	3.2										
WYN0.5-3.7	3.5	#6	3.7	6	7.0	15.7							
WYN0.5-4	4	#8	4.3				6.4						
WYN0.5-5	5	#10	5.3					8.0					
WYN1.25-3.2	3	#4	3.2	5.7	6.5	16.0	4.8	1.8	3.4	0.8	1000	HX-10 AN-10 AP-10 FSB-056TD	端头材质:紫铜 导线截面:0.5-1.5mm ² 最大电流:I _{max} =19A Wire range : 0.5-1.5mm ² A. W. G. : (22-16) Max.current=19A
WYN1.25-3.7S	3.5	#6	3.7										
WYN1.25-3.7L	3.5	#6	3.7	6.4									
WYN1.25-3.7LL	3.5	#6	3.7	7.2									
WYN1.25-4S	4	#8	4.3	6.4									
WYN1.25-4M	4	#8	4.3	7.2									
WYN1.25-4L	4	#8	4.3	8.1									
WYN1.25-5S	5	#10	5.3										
WYN1.25-5L	5	#10	5.3	9.5									
WYN1.25-6S	6	1/4 "	6.5										
WYN1.25-6L	6	1/4 "	6.5	12.0	11.0	22.0							
WYN1.25-8	8	5/16 "	8.5	13.5	11.5	21.5							
WYN2-3.2	3	#4	3.2	5.7	6.5	16.0	4.8	2.4	4.0	0.8	1000	HX-10 AN-10 AP-10 FSB-056TD	端头材质:紫铜 导线截面:1.5-2.5mm ² 最大电流:I _{max} =27A Wire range : 1.5-2.5mm ² A. W. G. : (16-14) Max.current=27A
WYN2-3.7S	3.5	#6	3.7										
WYN2-3.7L	3.5	#6	3.7	6.0									
WYN2-3.7LL	3.5	#6	3.7	7.2									
WYN2-4S	4	#8	4.3	6.4									
WYN2-4M	4	#8	4.3	7.2									
WYN2-4L	4	#8	4.3	8.1									
WYN2-5S	5	#10	5.3										
WYN2-5L	5	#10	5.3	9.5									
WYN2-6S	6	1/4 "	6.5										
WYN2-6L	6	1/4 "	6.5	12.0	11.0	22.0							
WYN2-8	8	5/16 "	8.5	13.5	11.5	21.8							

叉形裸端头(TU型)

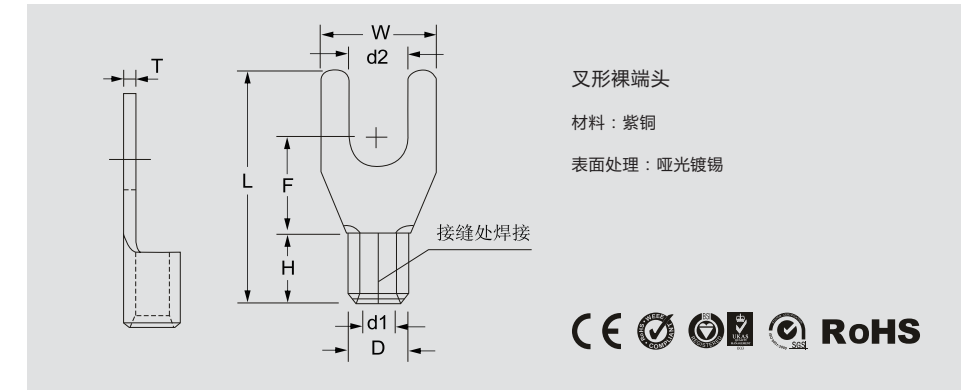

型号 ITEM NO.	STUD SIZE 螺栓口直径 美制螺栓号		尺寸 DIMENSION mm								包装 PCS/ PACK	使用工具 USE THE TOOLS	说明 EXPLANATION		
	Metric	American	d2	W	F	L	H	d1	D	T					
WYN3.5-3.7	3.5	#6	3.7	8.0	7.7	18.3	6.0	3.0	5.0	1.0	1000	HX-10 AN-10 AP-10 FSB-056TD	端头材质:紫铜 导线截面:2.5-4mm ² 最大电流:I _{max} =37A Wire range : 2.5-4mm ² A. W. G. : (14-12) Max.current=37A		
WYN3.5-4	4	#8	4.3												
WYN3.5-5	5	#10	5.3												
WYN3.5-6	6	1/4 "	6.5	12.0	9.1	21.5									
WYN3.5-8	8	5/16 "	8.5	14.0	11.5	23.7									
WYN3.5-10	10	3/8 "	10.5	17.5	12.5	26.5									
WYN5.5-3.7S	3.5	#6	3.7	8.3	7.0	18.5	6.0	3.5	5.5	1.0	1000	HX-10 AN-10 AP-10 FSB-056TD	端头材质:紫铜 导线截面:4-6mm ² 最大电流:I _{max} =48A Wire range : 4-6mm ² A. W. G. : (10-12) Max.current=48A		
WYN5.5-3.7	3.5	#6	3.7												
WYN5.5-4SS	4	#8	4.3	7.2	7.5	17.4									
WYN5.5-4S	4	#8	4.3	8.3	7.0	18.5									
WYN5.5-4L	4	#8	4.3	9.0	7.0	18.5									
WYN5.5-5	5	#10	5.3												
WYN5.5-6S	6	1/4 "	6.5												
WYN5.5-6L	6	1/4 "	6.5	12.0	12.0	24.7									
WYN5.5-8	8	5/16 "	8.5	14.0	11.5	23.7									
WYN5.5-10	10	3/8 "	10.5	17.5	12.5	26.5									
WYN8-4	4	#8	4.3	9.0	7.6	20.8	8.5	4.8	7.2	1.2	1000			HX-50B CT-80 FSC-616TD	端头材质:紫铜 导线截面:6-10mm ² 最大电流:I _{max} =62A Wire range : 6-10mm ² A. W. G. : (8) Max.current=62A
WYN8-5	5	#10	5.3	9.0	8.1										
WYN8-6	6	1/4 "	6.5	12.0	9.2	23.8									
WYN8-8	8	5/16 "	8.5	13.8	10.7	25.4									
WYN8-10	10	3/8 "	10.5	15.9											
WYN14-4	4	#8	4.3	9.0	9.5	25.5	10.5	6.0	9	1.4	500	HX-50B CT-80 FSC-616TD	端头材质:紫铜 导线截面:10-16mm ² 最大电流:I _{max} =88A Wire range : 10-16mm ² A. W. G. : (6) Max.current=88A		
WYN14-5	5	#10	5.3												
WYN14-6	6	1/4 "	6.5	11.0	9.5	25.5									
WYN14-8	8	5/16 "	8.5	13.8	10.7	28.5									
WYN14-10	10	3/8 "	10.5	15.9											
WYN22-5	5	#10	5.3	11.0	9.5	27.8	12	8.1	11.5	1.6	250	HX-50B CT-80	端头材质:紫铜 导线截面:16-25mm ² 最大电流:I _{max} =115A Wire range : 16-25mm ² A. W. G. : (4) Max.current=115A		
WYN22-6	6	1/4 "	6.5												
WYN22-8	8	5/16 "	8.5	16.5	13.5	33.5									
WYN22-10	10	3/8 "	10.5												

片形裸端头

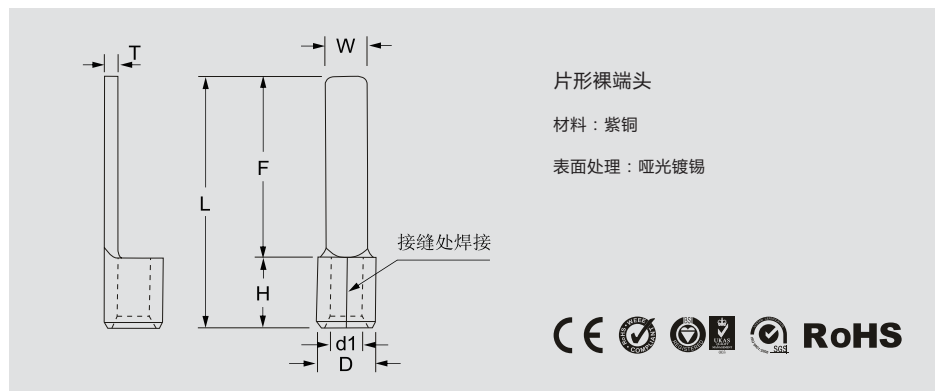

型号 ITEM NO.	尺寸 DIMENSION mm							包装 PCS/ PACK	使用工具 USE THE TOOLS	说明 EXPLANATION
	W	F	L	H	d1	D	T			
WPN1.25-9	2.8	9.0	13.8	4.8	1.8	3.4	0.8	1000	HX-10 AN-10 AP-10 FSB-056TD	端头材质:紫铜 导线截面:0.5-1.5mm ² 最大电流:Imax=19A Wire range : 0.5-1.5mm ² A. W. G. : (22-16) Max.current=19A
WPN1.25-10	2.3	10.0	14.8							
WPN1.25-11	3.0	11.0	15.8							
WPN1.25-11S	2.3									
WPN1.25-13	3.0	13.0	17.8							
WPN1.25-13S	2.3									
WPN1.25-14	3.0	14.0	18.8							
WPN1.25-14S	2.3									
WPN1.25-18	2.2	18.0	22.8							
WPN1.25-18S	2.0									
WPN2-9	3.0	9.0	13.8	4.8	2.4	4.0	0.8	1000	HX-10 AN-10 AP-10 FSB-056TD	端头材质:紫铜 导线截面:1.5-2.5mm ² 最大电流:Imax=27A Wire range : 1.5-2.5mm ² A. W. G. : (16-14) Max.current=27A
WPN2-10	2.4	10.0	14.8							
WPN2-13	2.4	13.0	17.8							
WPN2-13L	3.0									
WPN2-14	2.4	14.0	18.8							
WPN2-14L	3.0									
WPN2-18S	2.0	18.0	22.8							
WPN2-18	2.2									
WPN2-18L	2.8									
WPN5.5-10	2.8	10.0	16.0							
WPN5.5-14S	4.0	14.0	20.0							
WPN5.5-14	4.5	14.0								
WPN5.5-18S	2.0	18.0	24.0							
WPN5.5-18	4.5	18.0								
WPN8-14	5	14.0	22.5	8.5	4.8	7.2	1.2	500	HX-50B CT-80 FSC-616TD	
WPN14-16	6	16.0	26.5	10.5	6.0	9.0	1.4	500		
WPN22-16	6.5	16.0	28.0	12.0	8.1	11.5	1.7	250		
WPN38-16	6.5	16.0	30.0	14.0	9.7	13.3	1.7	200		

针形裸端头(TZ型)

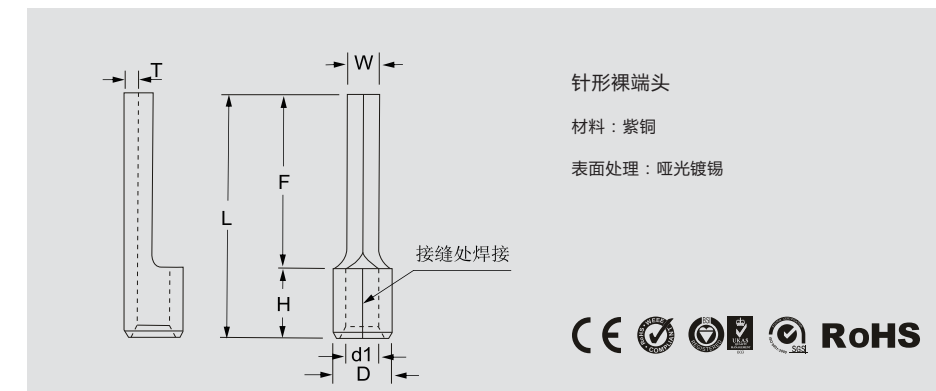

型号 ITEM NO.	尺寸 DIMENSION mm							包装 PCS/ PACK	使用工具 USE THE TOOLS	说明 EXPLANATION
	W	F	L	H	d1	D	T			
WZN1.25-9	1.9	9.0	13.8	4.8	1.8	3.4	0.8	1000	HX-10 AN-10 AP-10 FSB-056TD	端头材质:紫铜 导线截面:0.5-1.5mm ² 最大电流:Imax=19A Wire range : 0.5-1.5mm ² A. W. G. : (22-16) Max.current=19A
WZN1.25-10		10.0	14.8							
WZN1.25-12		12.0	16.8							
WZN1.25-13		13.0	17.8							
WZN1.25-17	1.9	17.0	21.8	4.8	2.4	4.0	0.8	1000	HX-10 AN-10 AP-10 FSB-056TD	端头材质:紫铜 导线截面:1.5-2.5mm ² 最大电流:Imax=27A Wire range : 1.5-2.5mm ² A. W. G. : (16-14) Max.current=27A
WZN2-9		9.0	13.8							
WZN2-10		10.0	14.8							
WZN2-12		12.0	16.8							
WZN2-13		13.0	17.8							
WZN2-17	17.0	21.8								
WZN3.5-13	2.8	13.0	19.0	6.0	3.0	5.0	1.0	1000	HX-10 AN-10 AP-10 FSB-056TD	端头材质:紫铜 导线截面:2.5-4mm ² 最大电流:Imax=37A Wire range : 2.5-4mm ² A. W. G. : (14-12) Max.current=37A
WZN5.5-13	2.8	13.0	19.0	6.0	3.5	5.5	1.0	1000	HX-10 AN-10 AP-10 FSB-056TD	端头材质:紫铜 导线截面:4-6mm ² 最大电流:Imax=48A Wire range : 4-6mm ² A. W. G. : (12-10) Max.current=48A
WZN5.5-25	2.8	25.0	31.0							
WZN8-25	4.0	28.0	36.5	8.5	4.8	7.2	1.2	500		端头材质:紫铜 导线截面:6-10mm ² 最大电流:Imax=62A A. W. G. : (8)
WZN14-25	4.0	28.5	39.0	10.5	6.0	9.0	1.4	500		端头材质:紫铜 导线截面:10-16mm ² 最大电流:Imax=88A A. W. G. : (6)
WZN22-25	5.0	28.5	40.5	12.0	8.1	11.5	1.7	250		端头材质:紫铜 导线截面:16-25mm ² 最大电流:Imax=115A A. W. G. : (4)
WZN35-25	5.0	28.5	42.5	14.0	9.7	13.3	1.7	200		端头材质:紫铜 导线截面:35mm ² 最大电流:Imax=160A A. W. G. : (2)

锁扣叉形裸端头

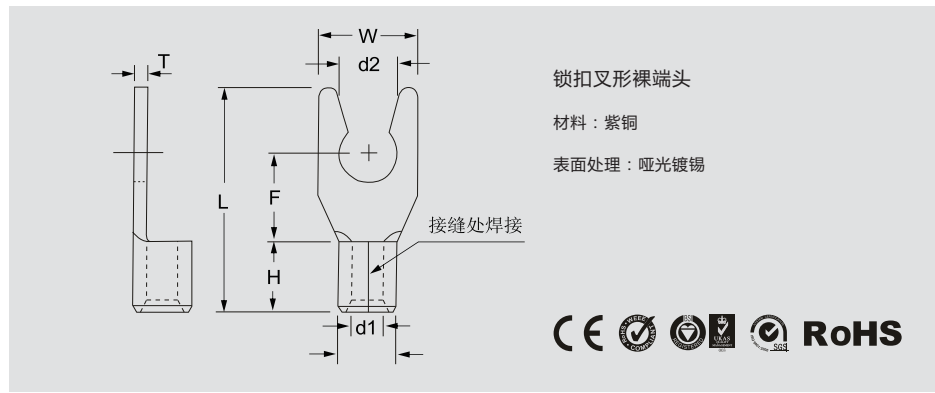

CE RoHS

型号 ITEM NO.	STUD SIZE 螺栓口直径 美制螺栓号		尺寸 DIMENSION mm								包装 PCS/ PACK	使用工具 USE THE TOOLS	说明 EXPLANATION
	Metric	American	d2	W	F	L	H	d1	D	T			
WYNSK1.25-3.7	3.5	#6	3.7	6.4	6.5	16.0	4.8	1.8	3.4	0.8	1000	HX-10 AN-10 AP-10 FSB-056TD	端头材质: 紫铜 导线截面: 0.5-1.5mm ² 最大电流: I _{max} =19A Wire range : 0.5-1.5mm ² A. W. G. : (22-16) Max.current=19A
WYNSK1.25-4	4	#8	4.3	7.2									
WYNSK1.25-5S	5	#10	5.3	8.1									
WYNSK1.25-5L	5	#10	5.3	9.5									
WYNSK2-3.7	3.5	#6	3.7	6.0	6.5	16.0	4.8	2.4	4.0	0.8	1000	HX-10 AN-10 AP-10 FSB-056TD	端头材质: 紫铜 导线截面: 1.5-2.5mm ² 最大电流: I _{max} =27A Wire range : 1.5-2.5mm ² A. W. G. : (16-14) Max.current=27A
WYNSK2-4	4	#8	4.3	7.2									
WYNSK2-4L	4	#8	4.3	8.1									
WYNSK2-5	5	#10	5.3	8.1									
WYNSK2-5L	5	#10	5.3	9.5									
WYNSK5.5-3.7	3.5	#6	3.7	8.3	7.0	18.5	6.0	3.5	5.5	1.0	1000	HX-10 AN-10 AP-10 FSB-056TD	端头材质: 紫铜 导线截面: 4-6mm ² 最大电流: I _{max} =48A Wire range : 4-6mm ² A. W. G. : (12-10) Max.current=48A
WYNSK5.5-4	4	#8	4.3	8.3									
WYNSK5.5-5	5	#10	5.3	9.0									
WYNSK5.5-6	6	1/4"	6.5	12.0									

开口端头

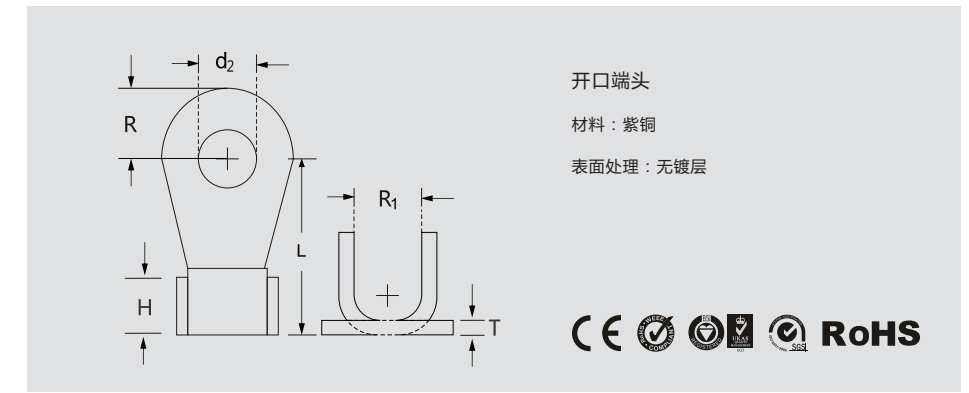

CE RoHS

型号 ITEM NO.	尺寸 DIMENSION mm						包装 PCS/ PACK
	L	H	T	R	R ₁	d ₂	
OT 10A	15	6	0.8	4.7	2	5.2	1000
OT 20A	17	7.4	1	5.5	2.5	6.2	1000
OT 30A	18	8.2	1.1	5.8	3.2	6.2	1000
OT 40A	20	9	1.1	6.1	3.5	6.2	1000
OT 50A	21.5	9	1.2	6.3	3.7	6.2	1000
OT 60A	23	10.5	1.3	7.2	4	8.2	500
OT 80A	23.5	11	1.4	8	4.5	8.2	500
OT 100A	29	12	1.5	8.5	5	8.2	500
OT 150A	31	12.4	1.6	9	5.5	10.2	200
OT 200A	33	14	1.7	10	6	10.2	200
OT 250A	36	15.5	1.8	10.5	6.5	10.2	200
OT 300A	40	17	2	11.5	7	12.2	200
OT 400A	43	18	2.2	13	8	14.2	100
OT 500A	46	20	2.4	14.5	8.5	14.4	100
OT 600A	50.5	23	2.7	16	10.5	16.5	100