

目次

電動代步車傳動軸

Transaxle for Powered Scooter

- TS53
差速器 (小型車)
Differential Gear 8
- TS63
差速器 (中型車)
Differential Gear 9
- TS80A
差速器 (中型車)
Differential Gear 10
- TS85
差速器 (大型車)
Differential Gear 11

各類傳動設備 Power Transmission

- PC100
行星式減速機 (中空型)
Right Angle, Hollow Shaft 12

電動堆高機 / 油壓拖板車 Power wheel

- PC77
臥式
Horizontal 13

風扇減速機 (排風扇) Fan

- EF1
臥式
Horizontal 14

電動輪椅傳動軸

Transaxle for Powered Wheelchair

- MD17
90度型 [有離合器功能]
Right angle, Clutch 2
- MD42
180度型 [大型直結式] 減速機
Parallel Shaft 3
- MD50
180度型 [小型直結式] 減速機
Parallel Shaft 4
- MD50A
180度型 [中型直結式] 減速機
Parallel Shaft 5
- MD50C
180度型 [中型直結式] 減速機
Parallel Shaft 6
- MW44
90度型 (蝸輪) 減速機
Right Angle 7

MODEL : MD17

RATIO : 21、25.7、28.6、32、43、48

用途：電動輪椅傳動軸

Application: Transaxle for Powered Wheelchair

型式：90 度型 [有離合器功能]

Specification: Right Angle, Clutch

段數：1 段蝸輪齒 +1 段平行齒輪

Stage: 2 stage, first stage is worm gear, second is helical gear set

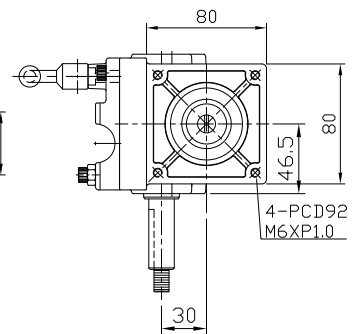
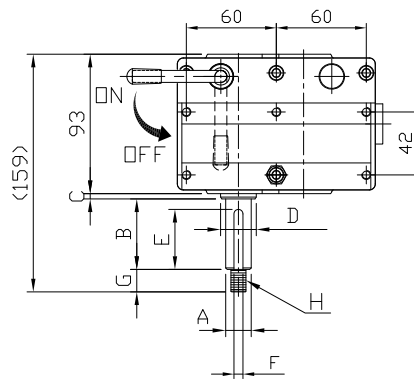
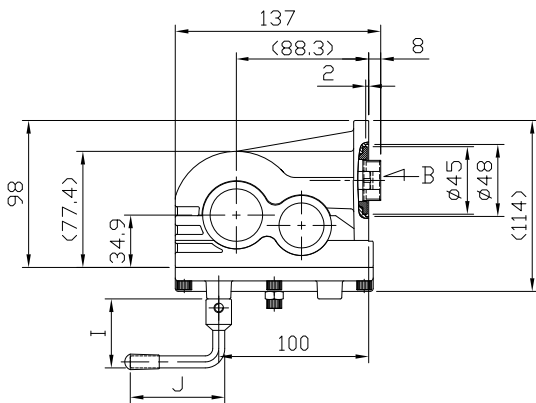

說明：參考載重 (機台重量 80kg+ 使用者載重 160kg) = 總重 ≤ 240kg (2 台)
 Max. Loading capacity : Wheel chair 80kg+ Personnel 160kg ≤ 240kg (2 pieces)

註：此圖為 (右軸)
 Remark: The drawing is right direction.

NO	A	B	C	D	E	F	G	H	I	J
規格說明	≤ Φ20	≤ 60	≤ 20	≤ Φ24.8	≤ 55	≤ 6	≤ 15	≤ 12	≤ 200	≤ 80

規格 Model No.	Ratio		21	25.7	28.6	32	43	48
	Unit							
額定輸出扭矩 (額定 / 連續運轉) Rated Output Torque	Nm		38	42	43	48	43	48
最大輸出扭矩 (急停 / 瞬間啟動) Max. Output Torque	Nm	3 倍額定輸出扭矩 3 Times of Rated Output Torque						
額定輸入轉速 Rated Input Speed	rpm	4,000						
最大輸入轉速 Max. Input Speed	rpm	5,300						
馬達額定功率 (僅供參考) Motor Rated Input Power	W	350W	350W	350W	350W	250W	250W	
噪音值 (量測距離 30cm) Noise Level(measured form 30cm)	dB	≤ 63	≤ 63	≤ 63	≤ 60	≤ 60	≤ 60	
容許徑向力 Max. Radial Force	kgf	400						
容許軸向力 Max. Axial Force	kgf	220						
效率 Efficiency	%	≥ 84	≥ 84	≥ 84	≥ 84	≥ 80	≥ 80	
使用環境溫度 Ambient Temperature	°C	-10°C ~ +40°C						
減速機重量 Reducer Weight ±3%	Kg	2.5						

MODEL : MD42

RATIO : 20、26、44.6

用途：電動輪椅傳動軸

型式：180 度型 [大型直結式] 減速機

段數：2 段平行齒輪

Application: Transaxle for Powered Wheelchair

Specification: Parallel Shaft

Stage: 2 stage, Helical Gear

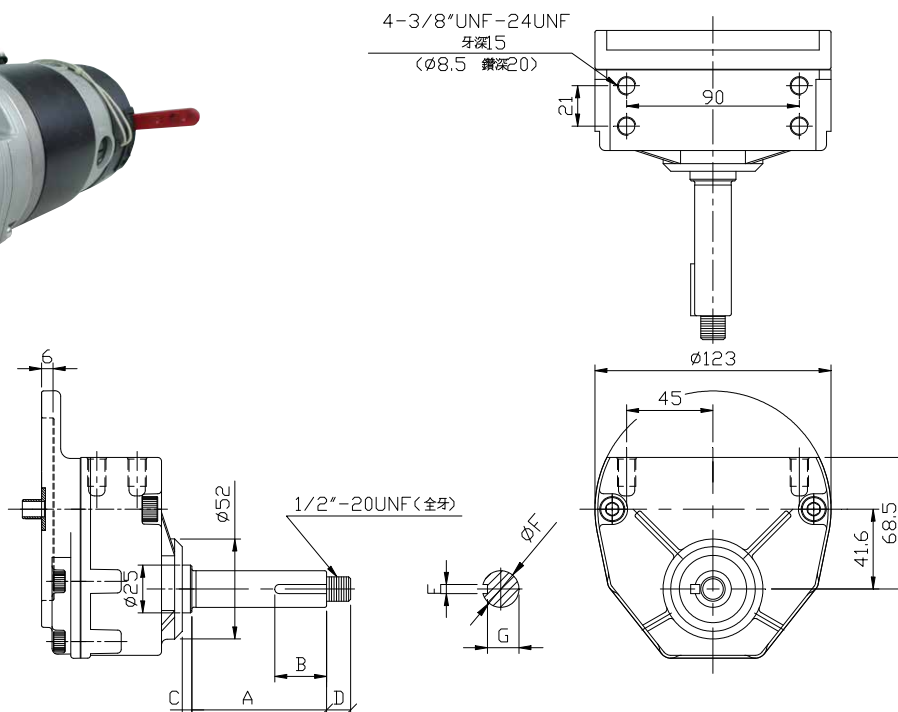

說明：參考載重 (機台重量 80kg+ 使用者載重 250kg) = 總重 \leq 330kg (2 台)

載重能力僅供參考，不在保證項目，請依實測為準。

Max. Loading capacity : Wheel chair 80kg+ Personnel 250kg \leq 330kg (2 pieces)

Load capacity is for reference only, not guaranteed items, please refer to actual measurement.

NO	A	B	C	D	E	F	G
規格說明	≤ 60	≤ 55	≤ 20	≤ 20	≤ 8	≤ 20	≥ 16

規格 Model No.	Ratio						
	Unit	20	26	44.6			
額定輸出扭矩 (額定 / 連續運轉) Rated Output Torque	Nm	35	40	47			
最大輸出扭矩 (急停 / 瞬間啟動) Max. Output Torque	Nm	3 倍額定輸出扭矩 3 Times of Rated Output Torque					
額定輸入轉速 / Rated Input Speed	rpm	4,000					
最大輸入轉速 / Max. Input Speed	rpm	5,000					
馬達額定功率 (僅供參考) Motor Rated Input Power	W	400	600	750			
噪音值 / Noise Level(量測距離 30cm)	dB	≤ 63	≤ 63	≤ 60			
容許徑向力 / Max. Radial Force	kgf	270					
容許軸向力 / Max. Axial Force	kgf	135					
效率 / Efficiency	%	≥ 90	≥ 88	≥ 85			
使用溫度 / Operating Temperature	°C	-15°C ~ +80°C					
減速機重量 / Reducer Weight $\pm 3\%$	Kg	2					

MODEL : MD50

RATIO : 8、13、15、17、19.3

用途：電動輪椅傳動軸

型式：180 度型 [小型直結式] 減速機

段數：1 段平行齒輪

Application: Transaxle for Powered Wheelchair

Specification: Parallel Shaft

Stage: 1 stage, Helical gear

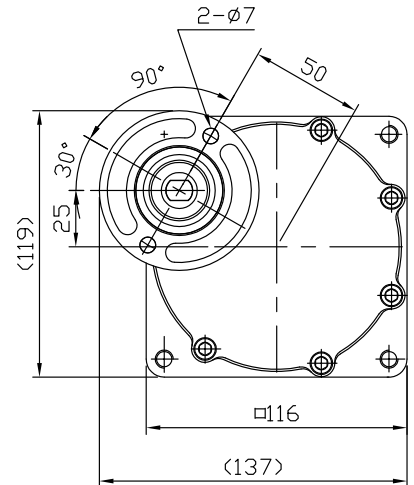
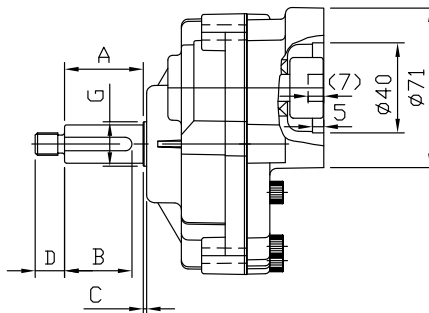
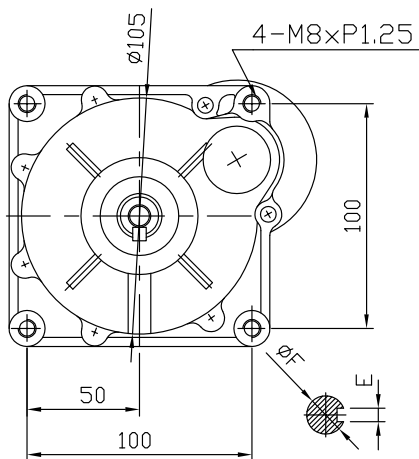

說明：參考載重 (機台重量 80kg+ 使用者載重 120kg) = 總重 \leq 200kg (2 台)
 載重能力僅供參考，不在保證項目，請依實測為準。

Max. Loading capacity : Wheel chair 80kg+ Personnel 120kg \leq 200kg (2 pieces)

Load capacity is for reference only, not guaranteed items, please refer to actual measurement.

NO	A	B	C	D	E	F	G
規格說明	≤ 60	≤ 55	≤ 10	≤ 18	≤ 6	$\leq \Phi 20$	$\leq \Phi 20$

規格 Model No.	Ratio	17	19.3				
額定輸出扭矩 (額定 / 連續運轉) Rated Output Torque	Nm	38	33.5				
最大輸出扭矩 (急停 / 瞬間啟動) Max. Output Torque	Nm	3 倍額定輸出扭矩 3 Times of Rated Output Torque					
額定輸入轉速 Rated Input Speed	rpm	3,500					
最大輸入轉速 Max. Input Speed	rpm	4,500					
馬達額定功率 (僅供參考) Motor Rated Input Power	W	400	400				
噪音值 Noise Level(量測距離 30cm)	dB	≤ 62	≤ 62				
容許徑向力 Max. Radial Force	kgf	600					
容許軸向力 Max. Axial Force	kgf	330					
效率 Efficiency	%	≥ 95	≥ 95				
使用溫度 Operating Temperature	°C	-25°C ~ +140°C					
減速機重量 Reducer Weight $\pm 3\%$	Kg	1.8					

MODEL : MD50A

RATIO : 17、19.3

用途：電動輪椅傳動軸

型式：180度型 [中型直結式] 減速機

段數：1 段平行齒輪

Application: Transaxle for Powered Wheelchair

Specification: Parallel Shaft

Stage: 1 stage, Helical gear

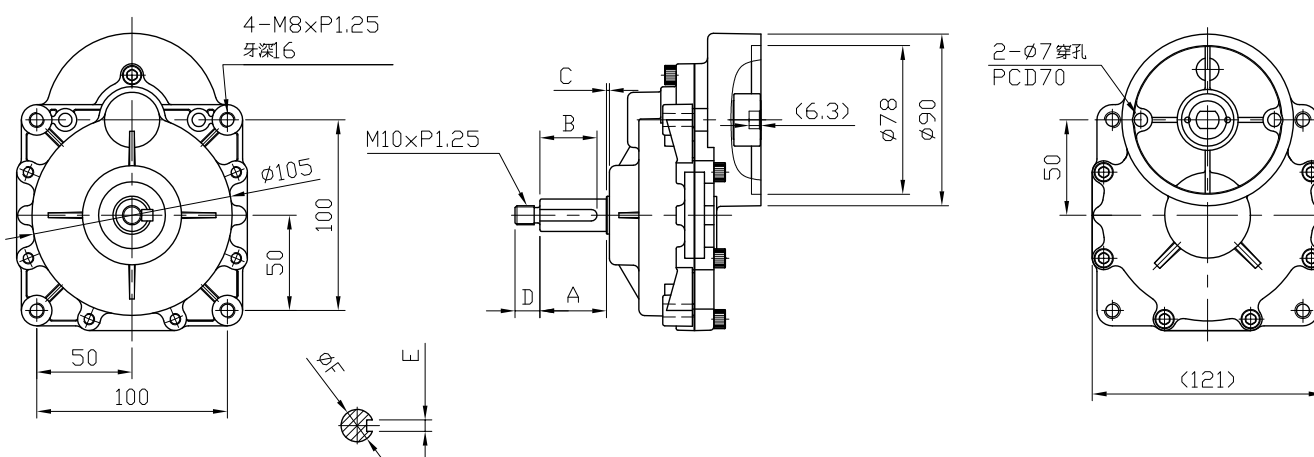

說明：參考載重 (機台重量 80kg+ 使用者載重 140kg) = 總重 ≤ 220 kg (2 台)
載重能力僅供參考，不在保證項目，請依實測為準。

Max. Loading capacity : Wheel chair 80kg+ Personnel 140kg ≤ 220 kg (2 pieces)

Load capacity is for reference only, not guaranteed items, please refer to actual measurement.

NO	A	B	C	D	E	F	G
規格說明	≤ 60	≤ 55	≤ 10	≤ 18	≤ 6	$\leq \phi 20$	$\leq \phi 20$

規格 Model No.	Ratio		17	19.3			
	Unit						
額定輸出扭矩 (額定 / 連續運轉) Rated Output Torque	Nm		30	35			
最大輸出扭矩 (急停 / 瞬間啟動) Max. Output Torque	Nm		3 倍額定輸出扭矩 3 Times of Rated Output Torque				
額定輸入轉速 Rated Input Speed	rpm					3,500	
最大輸入轉速 Max. Input Speed	rpm					4,500	
馬達額定功率 (僅供參考) Motor Rated Input Power	W		300	300			
噪音值 Noise Level (量測距離 30cm)	dB		≤ 62	≤ 62			
容許徑向力 Max. Radial Force	kgf					600	
容許軸向力 Max. Axial Force	kgf					330	
效率 Efficiency	%		≥ 95	≥ 95			
使用溫度 Operating Temperature	$^{\circ}\text{C}$		-15 $^{\circ}\text{C}$ ~ +80 $^{\circ}\text{C}$				
減速機重量 Reducer Weight $\pm 3\%$	Kg		1.8				

MODEL : MD50C

RATIO : 17、19.3

用途：電動輪椅傳動軸

型式：180 度型 [中型直結式] 減速機

段數：1 段平行齒輪

Application: Transaxle for Powered Wheelchair

Specification: Parallel Shaft

Stage: 1 stage, Helical gear

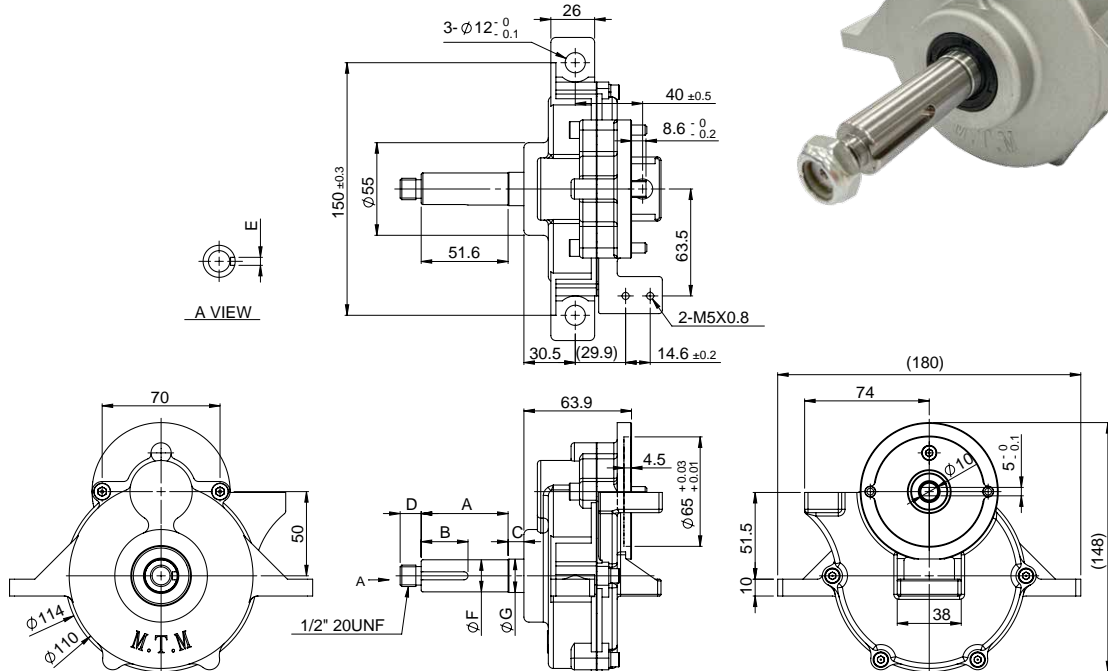
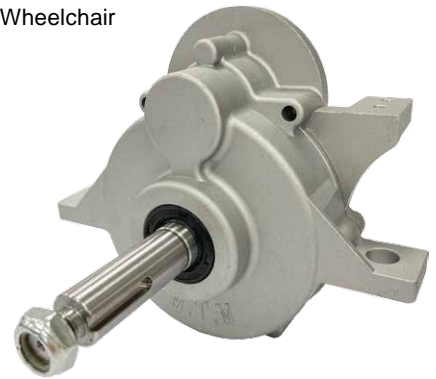

說明：參考載重 (機台重量 80kg+ 使用者載重 140kg) = 總重 ≤ 220 kg (2 台)
 載重能力僅供參考，不在保證項目，請依實測為準。

Max. Loading capacity : Wheel chair 80kg+ Personnel 140kg ≤ 220 kg (2 pieces)

Load capacity is for reference only, not guaranteed items, please refer to actual measurement.

NO	A	B	C	D	E	F	G
規格說明	≤ 60	≤ 55	≤ 10	≤ 18	≤ 6	$\leq \phi 20$	$\leq \phi 20$

規格 Model No.	Ratio					
	Unit	17	19.3			
額定輸出扭矩 (額定 / 連續運轉) Rated Output Torque	Nm	30	35			
最大輸出扭矩 (急停 / 瞬間啟動) Max. Output Torque	Nm	3 倍額定輸出扭矩 3 Times of Rated Output Torque				
額定輸入轉速 Rated Input Speed	rpm	3,500				
最大輸入轉速 Max. Input Speed	rpm	4,500				
馬達額定功率 (僅供參考) Motor Rated Input Power	W	300	300			
噪音值 Noise Level(量測距離 30cm)	dB	≤ 62	≤ 62			
容許徑向力 Max. Radial Force	kgf	250				
容許軸向力 Max. Axial Force	kgf	120				
效率 Efficiency	%	≥ 95	≥ 95			
使用溫度 Operating Temperature	$^{\circ}\text{C}$	-15 $^{\circ}\text{C}$ ~ +80 $^{\circ}\text{C}$				
減速機重量 Reducer Weight $\pm 3\%$	Kg	1.8				

MODEL : MW44

RATIO : 8.5 · 15 · 20 · 25 · 30 · 50 · 60

用途：電動輪椅傳動軸

型式：90 度型（蝸輪）減速機

段數：1 段蝸輪式

Application: Transaxle for Powered Wheelchair

Specification: Right Angle

Stage: 1 stage, worm gear

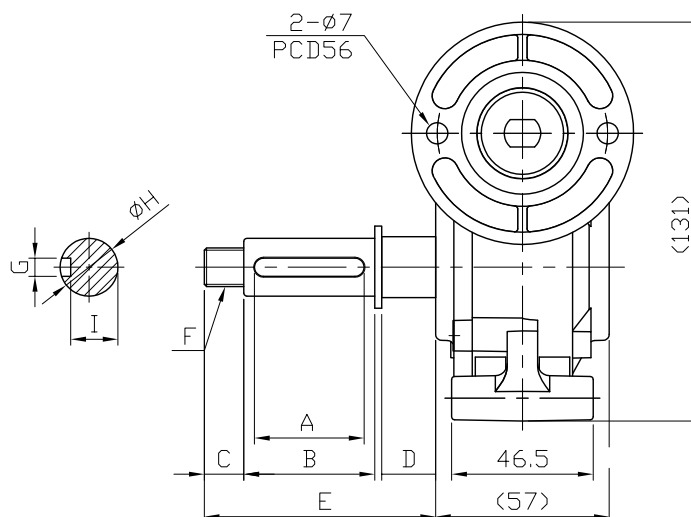
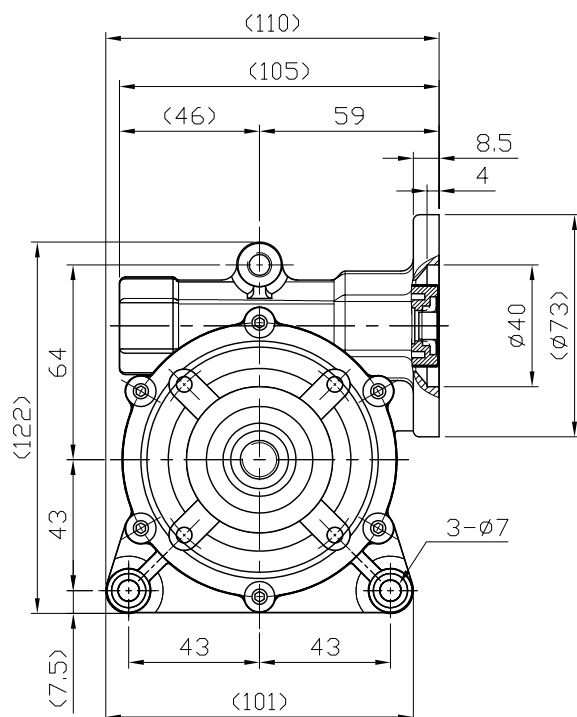

說明：參考載重（機台重量 80kg+ 使用者載重 120kg）= 總重 ≤ 200kg(2 台)

Max. Loading capacity : Wheel chair 80kg+ Personnel 120kg ≤ 200kg (2 pieces)

註：此圖為（左軸）

Remark: The drawing is left direction.

NO	A	B	C	D	E	F	G	H	I
規格說明	≤ 45	≤ 50	≤ 20	≤ 20	≤ 90	≤ M12	≤ 8	≤ Φ20	≥ 16

規格 Model No.	Unit	Ratio							
		8.5	15	20	25	30	50	60	
額定輸出扭矩 (額定 / 連續運轉) Rated Output Torque	Nm	10	15	18	25	35	45	50	
最大輸出扭矩 (急停 / 瞬間啟動) Max. Output Torque	Nm	3 倍額定輸出扭矩 3 Times of Rated Output Torque							
額定輸入轉速 Rated Input Speed	rpm	4,000							
最大輸入轉速 Max. Input Speed	rpm	4,500							
馬達額定功率 (僅供參考) Motor Rated Input Power	W	350	350	350	300	300	250	250	
噪音值 Noise Level(量測距離 30cm)	dB	≤ 65	≤ 65	≤ 62	≤ 62	≤ 62	≤ 60	≤ 60	
容許徑向力 Max. Radial Force	kgf	600							
容許軸向力 Max. Axial Force	kgf	310							
效率 Efficiency	%	92	89	85	83	80	78	75	
使用溫度 Operating Temperature	°C	-15°C ~ +80°C							
減速機重量 Reducer Weight ±3%	Kg	1.5							

MODEL : TS53

RATIO : 17.3・20.3

用途：電動代步車傳動軸

型式：差速器 (小型車)

段數：1 段平行齒輪 + 4 只傘齒輪

Application: Transaxle for Powered Scooter

Specification: Differential Gear

Stage: 1 stage, helical gear + bevel gear

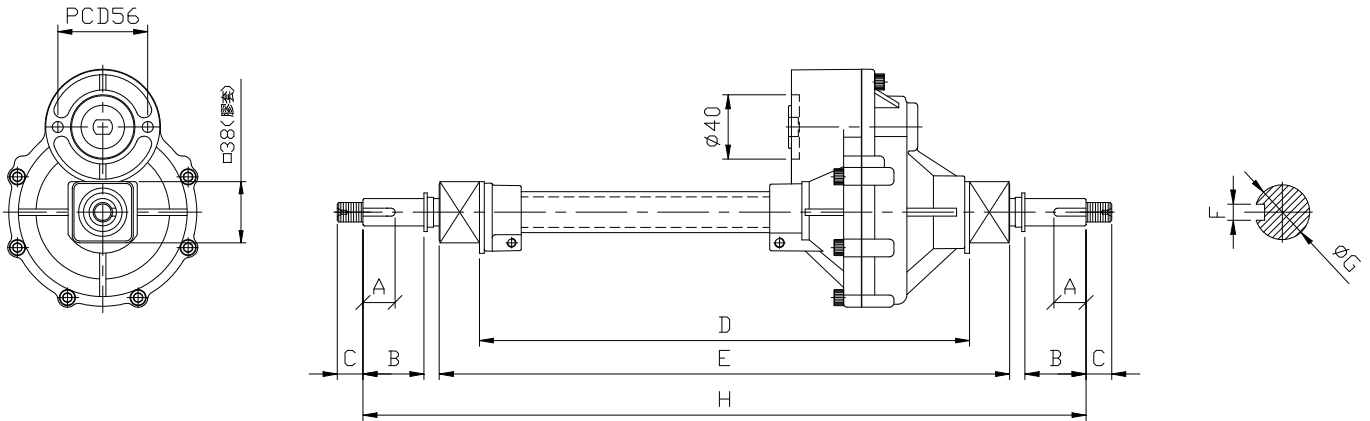
說明：參考載重 (機台重量 80kg+ 使用者載重 130kg) = 總重 \leq 210kgMax. Loading capacity : Wheel chair 80kg+ Personnel 130kg \leq 210kg

NO	A	B	C	D	E	F	G	H
規格說明	≤ 30	≤ 40	≤ 16	≤ 400	≤ 450	≤ 6	$\leq \Phi 17$	≤ 550

規格 Model No.	Ratio							
	Unit	17.3	20.3					
額定輸出扭矩 (額定 / 連續運轉) Rated Output Torque	Nm	35	25					
最大輸出扭矩 (急停 / 瞬間啟動) Max. Output Torque	Nm	3 倍額定輸出扭矩 3 Times of Rated Output Torque						
額定輸入轉速 Rated Input Speed	rpm	3,600						
最大輸入轉速 Max. Input Speed	rpm	5,300						
馬達額定功率 (僅供參考) Motor Rated Input Power	W	300W	200W					
噪音值 Noise Level(量測距離 30cm)	dB	≤ 62	≤ 62					
容許徑向力 Max. Radial Force	kgf	263						
容許軸向力 Max. Axial Force	kgf	130						
效率 Efficiency	%	≥ 95	≥ 95					
使用溫度 Operating Temperature	$^{\circ}\text{C}$	$-15^{\circ}\text{C} \sim +80^{\circ}\text{C}$						
減速機重量 Reducer Weight $\pm 3\%$	Kg	3.5						

MODEL : TS63

RATIO : 14.8、15.5、19.7、20.7、22.7

用途：電動代步車傳動軸

型式：差速器（中型車）

段數：1 段平行齒輪 +4 只傘齒輪

Application: Transaxle for Powered Scooter

Specification: Differential Gear

Stage: 1 stage, helical gear + bevel gear

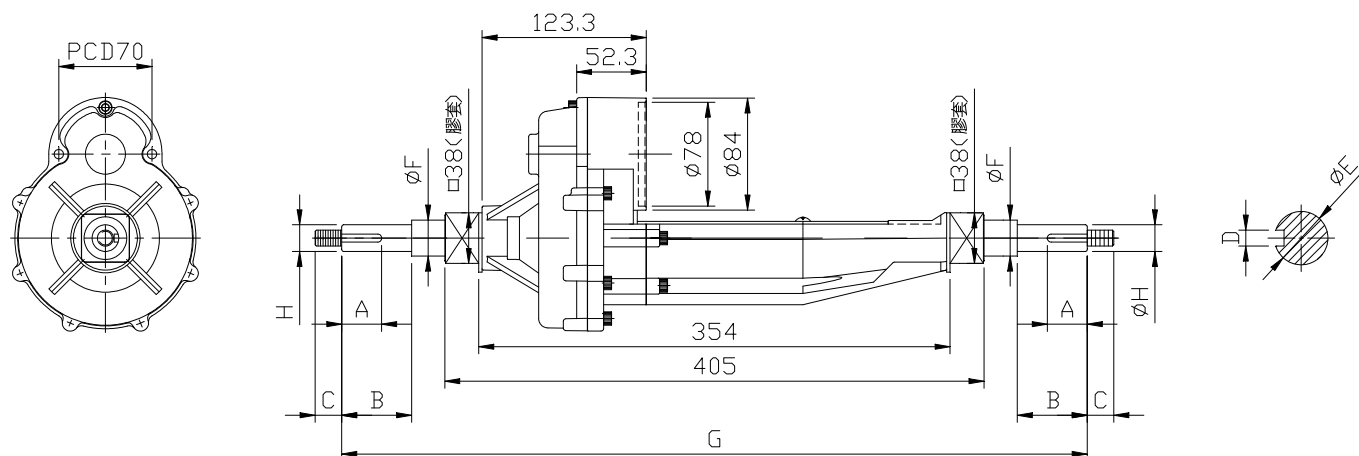
說明：參考載重（機台重量 80kg+ 使用者載重 160kg）= 總重 \leq 240kgMax. Loading capacity : Wheel chair 80kg+ Personnel 160kg \leq 240kg

NO	A	B	C	D	E	F	G
規格說明	≤ 65	≤ 70	≤ 20	≤ 8	$\leq \Phi 20$	$\leq \Phi 20$	≤ 600

規格 Model No.	Ratio						
	Unit	14.8	15.5	19.7	20.7	22.7	
額定輸出扭矩（額定 / 連續運轉） Rated Output Torque	Nm	55	57.5	57.5	59	71	
最大輸出扭矩（急停 / 瞬間啟動） Max. Output Torque	Nm	3 倍額定輸出扭矩 3 Times of Rated Output Torque					
額定輸入轉速 Rated Input Speed	rpm	4,700					
最大輸入轉速 Max. Input Speed	rpm	5,300					
馬達額定功率（僅供參考） Motor Rated Input Power	W	400W	400W	300W	300W	300W	
噪音值 Noise Level(量測距離 30cm)	dB	≤ 65	≤ 65	≤ 62	≤ 62	≤ 62	
容許徑向力 Max. Radial Force	kgf	280					
容許軸向力 Max. Axial Force	kgf	150					
效率 Efficiency	%	≥ 95	≥ 95	≥ 95	≥ 95	≥ 95	
使用溫度 Operating Temperature	$^{\circ}\text{C}$	$-15^{\circ}\text{C} \sim +80^{\circ}\text{C}$					
減速機重量 Reducer Weight $\pm 3\%$	Kg	5.5					

MODEL : TS80A

RATIO : 13.9、17.1、19.2、21.6、24.5、34.4

用途：電動代步車傳動軸

Application: Transaxle for Powered Scooter

型式：差速器 (中型車)

Specification: Differential Gear

段數：2 段平行齒輪 +4 只傘齒輪

Stage: 2 stage, helical gear + bevel gear

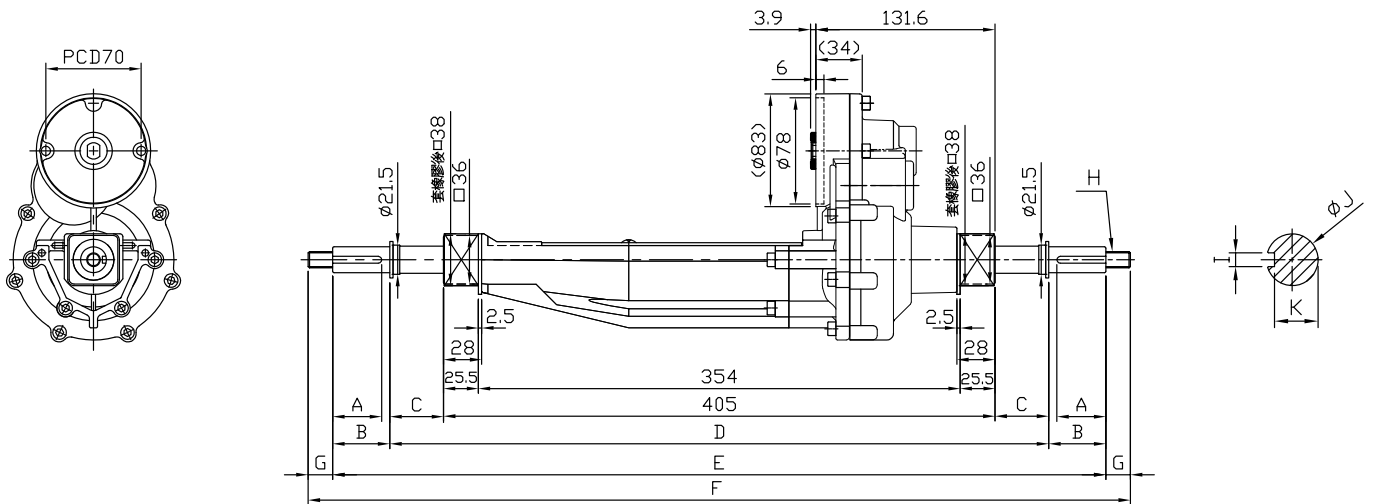
說明：參考載重 (機台重量 80kg+ 使用者載重 180kg) = 總重 \leq 260kgMax. Loading capacity : Wheel chair 80kg+ Personnel 180kg \leq 260kg

NO	A	B	C	D	E	F	G	H	I
規格說明	$\leq \Phi 20$	≤ 8	≥ 16	≤ 600	≤ 70	≤ 27.5	≤ 65	$\leq \Phi 20$	≤ 20

規格 Model No.	Ratio	13.9	17.1	19.2	21.6	24.5	34.4
	Unit						
額定輸出扭矩 (額定 / 連續運轉) Rated Output Torque	Nm	60	60	60	63	67	67
最大輸出扭矩 (急停 / 瞬間啟動) Max. Output Torque	Nm	3 倍額定輸出扭矩 3 Times of Rated Output Torque					
額定輸入轉速 Rated Input Speed	rpm	4,700					
最大輸入轉速 Max. Input Speed	rpm	5,300					
馬達額定功率 (僅供參考) Motor Rated Input Power	W	500W	500W	500W	400W	400W	400W
噪音值 Noise Level(量測距離 30cm)	dB	≤ 68	≤ 65	≤ 62	≤ 62	≤ 62	≤ 62
容許徑向力 Max. Radial Force	kgf	350					
容許軸向力 Max. Axial Force	kgf	170					
效率 Efficiency	%	≥ 90	≥ 90	≥ 90	≥ 90	≥ 90	≥ 90
使用溫度 Operating Temperature	°C	-15°C ~ +80°C					
減速機重量 Reducer Weight $\pm 3\%$	Kg	4.5					

MODEL : TS85

RATIO : 13.1、16.1、20.7、23、25、32、48

用途：電動代步車傳動軸

型式：差速器（大型車）

段數：2 段平行齒輪 +4 只傘齒輪

Application: Transaxle for Powered Scooter

Specification: Differential Gear

Stage: 2 stage, helical gear + bevel gear

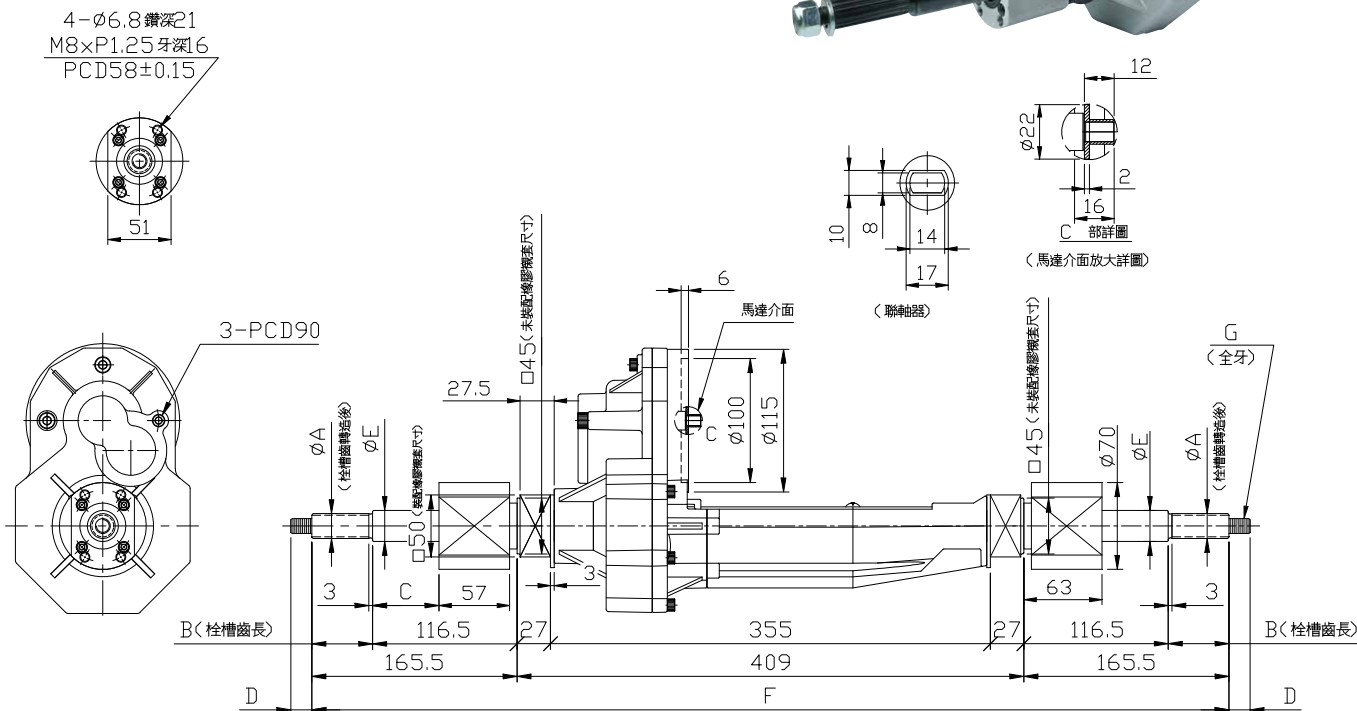
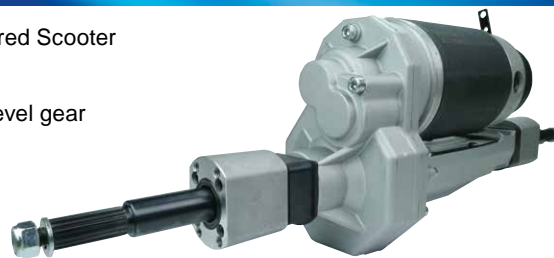

說明：參考載重（機台重量 100kg+ 使用者載重 250kg）= 總重 ≤ 350kg

Max. Loading capacity : Wheel chair 100kg+ Personnel 250kg ≤ 350kg

NO	A	B	C	D	E	F	G
規格說明	≤ Φ20	≤ 49	≤ 53.5	≤ 20	≤ Φ25	≤ 740	≤ M12

規格 Model No.	Unit	Ratio							
		13.1	16.1	20.7	23	25	32	48	
額定輸出扭矩（額定 / 連續運轉） Rated Output Torque	Nm	80	80	80	95	115	115	115	
最大輸出扭矩（急停 / 瞬間啟動） Max. Output Torque	Nm	3 倍額定輸出扭矩 3 Times of Rated Output Torque							
額定輸入轉速 Rated Input Speed	rpm	4,700							
最大輸入轉速 Max. Input Speed	rpm	5,300							
馬達額定功率（僅供參考） Motor Rated Input Power	W	1000W	1000W	1000W	800W	800W	800W	800W	
噪音值 Noise Level(量測距離 30cm)	dB	≤ 72	≤ 72	≤ 72	≤ 70	≤ 70	≤ 70	≤ 70	
容許徑向力 Max. Radial Force	kgf	580							
容許軸向力 Max. Axial Force	kgf	270							
效率 Efficiency	%	≥ 90	≥ 90	≥ 90	≥ 90	≥ 90	≥ 90	≥ 90	
使用溫度 Operating Temperature	℃	-15℃ ~ +80℃							
減速機重量 Reducer Weight ±3%	Kg	9.5							

MODEL : PC100

RATIO : 30、39、62、82

用途：各類傳動設備

Application: Power Transmission

型式：行星式減速機 (中空型)

Specification: Right Angle, Hollow Shaft

段數：2 段行星齒輪 + 1 段傘齒輪

Stage: 2 stage Planetary gear + 1 stage bevel gear

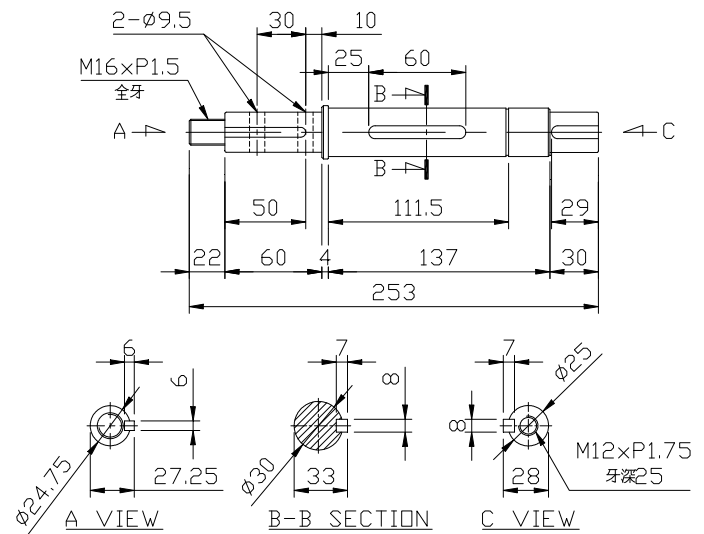
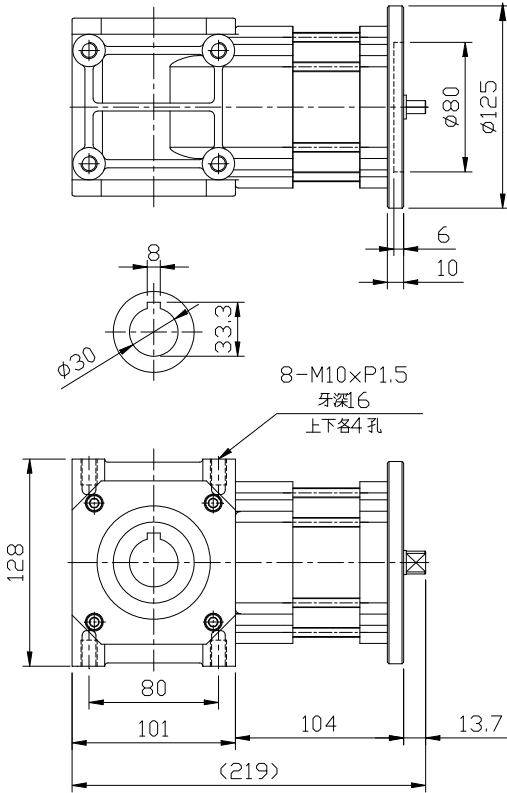

規格 Model No.	Unit	Ratio	30	39	62	82	
額定輸出扭矩 (額定 / 連續運轉) Rated Output Torque	Nm						
最大輸出扭矩 (急停 / 瞬間啟動) Max. Output Torque	Nm	3 倍額定輸出扭矩 3 Times of Rated Output Torque					
額定輸入轉速 Rated Input Speed	rpm		4,000				
最大輸入轉速 Max. Input Speed	rpm		5,000				
馬達額定功率 (僅供參考) Motor Rated Input Power	W		1,500	1,500	1,000	1,000	
噪音值 Noise Level(量測距離 30cm)	dB		≤ 70	≤ 70	≤ 70	≤ 67	
容許徑向力 Max. Radial Force	kgf		1,700				
容許軸向力 Max. Axial Force	kgf		900				
效率 Efficiency	%		88	88	86	85	
使用溫度 Operating Temperature	°C		-15°C ~ +80°C				
減速機重量 Reducer Weight ±3%	Kg		7.3				

MODEL : PC77

RATIO : 35.7

用途：電動堆高機 / 油壓拖板車 (動力輪減速機)

Application: Power wheel

型式：臥式

Specification: Horizontal

段數：1 段平行齒輪 +1 段內齒輪

Stage: 1 stage helical gear + 1 stage Planetary gear

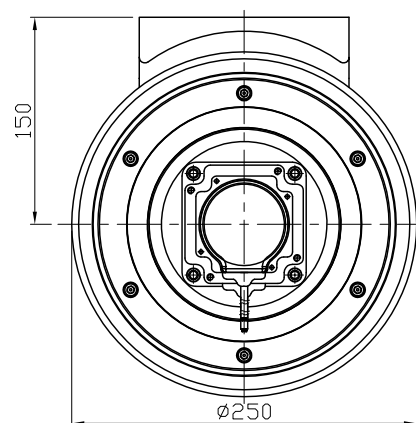
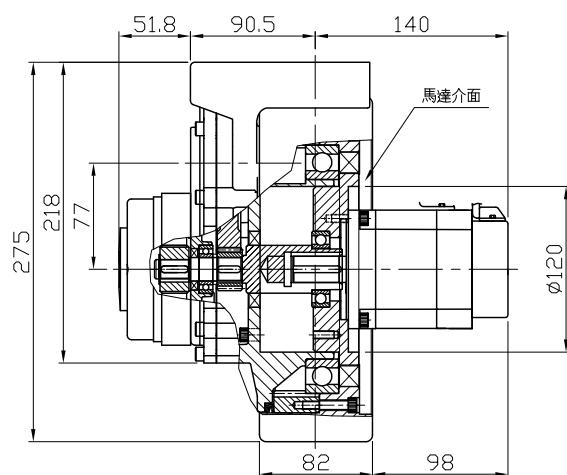
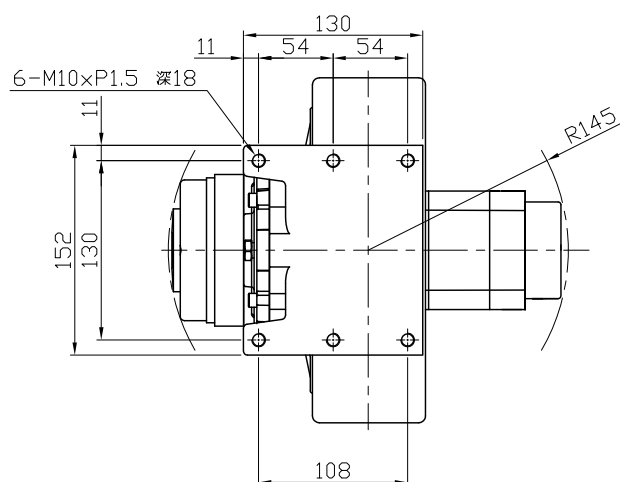

規格 Model No.	Unit	Ratio	35.7				
額定輸出扭矩 (額定 / 連續運轉) Rated Output Torque	Nm	400					
最大輸出扭矩 (急停 / 瞬間啟動) Max. Output Torque	Nm	3 倍額定輸出扭矩 3 Times of Rated Output Torque					
額定輸入轉速 Rated Input Speed	rpm				3,600		
最大輸入轉速 Max. Input Speed	rpm				5,300		
馬達額定功率 (僅供參考) Motor Rated Input Power	W	2000W					
噪音值 Noise Level(量測距離 30cm)	dB	≤ 80					
容許徑向力 Max. Radial Force	kgf				1,500		
容許軸向力 Max. Axial Force	kgf				802		
效率 Efficiency	%	90					
使用溫度 Operating Temperature	°C				-15°C ~ +80°C		
減速機重量 Reducer Weight $\pm 3\%$	Kg				29		

PC77

MODEL : EF1

RATIO : 3.1、3.8、4.1、4.6

用途：風扇減速機（排風扇）
 型式：臥式
 段數：1 段平行齒輪

Application: Fan
 Specification: Horizontal
 Stage: 1 stage helical gear

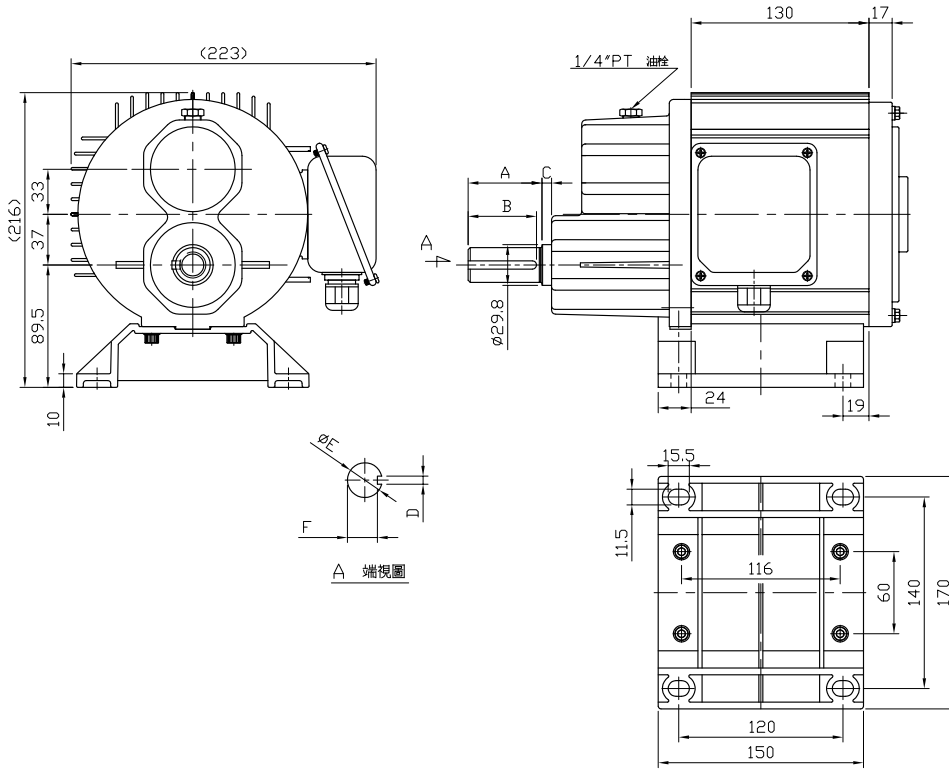

NO	A	B	C	D	E	F
規格說明	≤ 70	≤ 65	≤ 10	≤ 8	≤ Φ30	≥ 26

規格 Model No.	Ratio				
	Unit	3.1	3.8	4.1	4.6
額定輸出扭矩 (額定 / 連續運轉) Rated Output Torque	Nm	42	45	47	47
最大輸出扭矩 (急停 / 瞬間啟動) Max. Output Torque	Nm	3 倍額定輸出扭矩 3 Times of Rated Output Torque			
額定輸入轉速 Rated Input Speed	rpm	1,750			
最大輸入轉速 Max. Input Speed	rpm	1,750			
馬達額定功率 (僅供參考) Motor Rated Input Power	W	1,100	1,100	750	750
噪音值 Noise Level(量測距離 30cm)	dB	≤ 58	≤ 58	≤ 58	≤ 58
容許徑向力 Max. Radial Force	kgf	700			
容許軸向力 Max. Axial Force	kgf	400			
效率 Efficiency	%	≥ 95	≥ 95	≥ 95	≥ 95
使用溫度 Operating Temperature	°C	-15°C ~ +80°C			
減速機重量 Reducer Weight ±3%	Kg	13.5			

TRANSAXLE REDUCERS

傳動軸減速機系列 Transaxle Reducer Series



2021 年 1 月版

- 由於產品改良，未經通告變更印刷製品規格，請諒察。
- 由於印刷特性與拍攝技術的關係，印刷顏色與實物稍有差異，請諒察。
- 產品專利及版權所有，非經本公司同意，不得轉載本刊任何圖文或仿冒商品。
- 本目錄於製作時已力求完美，但因機種繁多，校稿疏失在所難免，請於訂貨時與業務人員進行確認。

January, 2021

- We ask for your understanding if due to product improvements and the product in this catalogue have not yet been update.
- We also ask for your understanding if due to printing limitations the objects and colors in this catalogue do not match the actual products exactly.
- The products in this catalogue have been registered with the patents office.
- The reprinting of this publication in any form or the imitation of any of the products described within is expressly forbidden without the express permission of the LI MING MACHINERY CO., LTD.