

# 3270RB 空心杯无刷电机

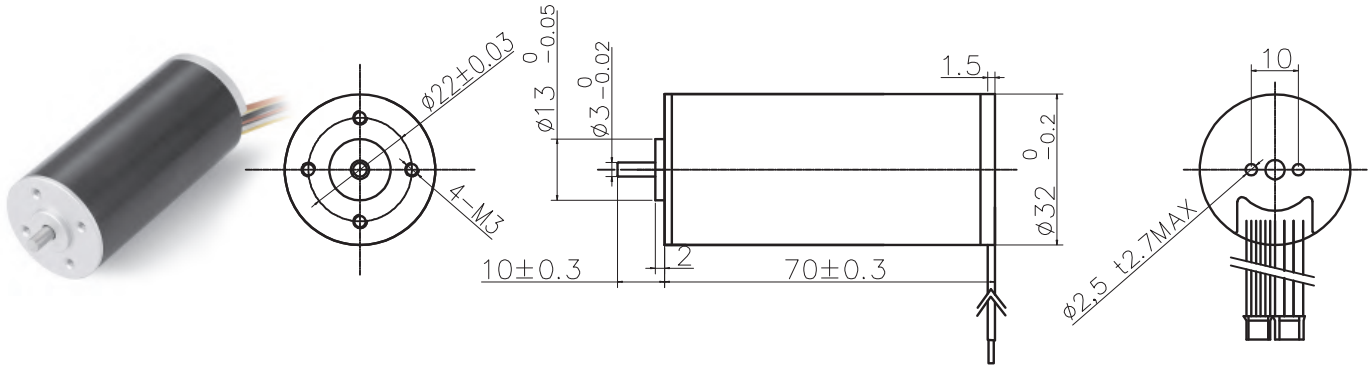

典型应用 Typical Applications: 舵机、智能小机器人

电机参数 ( Motor data )		03A	02A			
额定电压下数值 (Values at nominal voltage)						
1	额定电压 (Nominal voltage)	v	21	40		
2	空载转速 (No load speed)	rpm	15000	15500		
3	空载电流 (No load current)	mA	440	190		
4	额定转速 (Nominal speed)	rpm	13275	13800		
5	额定转矩 (最大连续转矩) (Nominal torque)	mNm	100	100		
6	额定电流 (最大连续电流) (Nominal current)	A	8.17	4.37		
7	堵转转矩 (Stall torque)	mNm	887	966		
8	堵转电流 (Stall current)	A	67.74	40		
9	最大效率 (Max efficiency)	%	85	87		
电机常数 (Motor constant)						
10	相间电阻 (Terminal resistance)	$\Omega$	0.31	1.00		
11	转矩常数 (Torque constant)	mNm/A	13.11	24.16		
12	速度常数 (Speed constant)	rpm / V	714	388		

## 其它特性参数 Other characteristic parameters 03A电机曲线图

- 13 环境温度范围 (Ambient temperature) -10 - 40°C
- 14 绕组最高允许温度 (Max permissible winding temperature) 120°C
- 15 最高允许转速 (Max permissible speed) 20000rpm
- 16 电极磁极对数 (Number of the pole pairs) 1
- 17 相数 (Number of pole pairs) 3
- 18 电机质量 (Weight) 225g

端子定义：  
 PIN1-PIN3 电机绕组 C B A  
 PIN4 GND  
 PIN5-PIN7 传感器 HC  
 PIN8 VCC

